



INSTRUCTIONS 1010-L00 e

Section	1010
Effective	March 2024
Replaces	March 2018

Original instructions

CC8-80 F - CC8-100 F *pumps*



INSTALLATION

OPERATION

MAINTENANCE

EC CERTIFICATE OF CONFORMITY :

The EC Certificate of Conformity (paper version) is systematically attached to the equipment when shipped.

WARRANTY :

CC8 Series pumps are covered 24 months by warranty within the limits mentioned in our General Sales Conditions. In case of a use other than that mentioned in the Instructions manual, and without preliminary agreement of MOUVEX, warranty will be canceled.



Z.I. La Plaine des Isles - F 89000 AUXERRE - FRANCE
Tel. : +33 (0)3.86.49.86.30 - Fax : +33 (0)3.86.49.87.17
contact.mouvex@psgdover.com - www.mouvex.com

Your distributor :

TANK TRUCK PUMP

SAFETY, STORAGE, INSTALLATION AND MAINTENANCE INSTRUCTIONS

MODELS : CC8-80 F - CC8-100 F

Definition of safety symbols



This is a SAFETY ALERT SYMBOL.

When you see this symbol on the product, or in the manual, look for one of the following signal words and be alert to the potential for personal injury, death or major property damage.



Warns of hazards that **WILL** cause serious personal injury, death or major property damage.



Warns of hazards that **CAN** cause serious personal injury, death or major property damage.



Warns of hazards that **CAN** cause personal injury or property damage.

NOTICE

Indicates special instructions which are very important and must be followed.

REMARKS :

CC8 pumps **MUST** be installed in systems designed by qualified personnel. The installation **MUST** be in compliance with local standards, national regulations and rules of safety.

This manual is designed to permit installation and commissioning of CC8 pumps and MUST accompany the pump.

Maintenance of CC8 pumps must ONLY be carried out by qualified technicians. This maintenance must meet local and national standards as well as all safety regulations. Read this manual, including all instructions and warnings, in full BEFORE any use of CC8 pumps.

Do not remove the warning and use label stickers that are found on the CC8 pumps.

NOTA :

The numbers written in bold characters after part names correspond to items specified in the spare Parts list.

TABLE OF CONTENTS

Page

1. PRESENTATION	3
2. OPERATING LIMITS	3
3. OVERALL DIMENSIONS	4
4. INSTALLATION	5
4.1 Choice of pump	5
4.2 Direction of rotation	5
4.3 Pump protection	5
4.4 Pipe diameter	5
4.5 Piping assembly	5
4.6 Bypass setting	5
5. DIRECT DRIVE BY MOTOR	6
5.1 Installation of units	6
5.2 Alignment of motor/pump and reduction gearbox/pump shafts	6
5.3 Electric motors	7
5.4 Diesel engines drive	7
6. DRIVE BY POWER TAKE OFF	7
7. USE	8
7.1 Pumping hot liquids	8
7.2 Pump full of liquid when stopped	8
7.3 Starting-up the pump	8
7.4 Running without liquid in the pump	8
7.5 Using of the pump with a valve closed on the discharge line	8
7.6 Shutting down the pump	8
7.7 Protection from frost	9
7.8 Restarting	9
8. NECESSARY TOOLS	10
9. DISMANTLING - REASSEMBLY	10
9.1 Side opposite to drive system	11
9.2 Drive side	11
9.3 Assembly of flange for hydraulic trunk	12
10. CHANGING THE VANES	12
11. CHANGING MECHANICAL SEAL AND BALL BEARINGS 13	
12. MECHANICAL BYPASS	13
13. PNEUMATIC BYPASS	14
13.1 Dismantling	14
13.2 Membrane and seals 804, 815, 837 control (adjustable bypass) :	14
13.3 Access to the membrane	14
13.4 Reassembling	14
14. MAINTENANCE	15
14.1 Lubrication	15
14.2 Inspection of the vanes	15
14.3 Cleaning the filter	15
15. TROUBLESHOOTING	15
15.1 Abnormal noise	15
15.2 Leaking seal	15
15.3 Inadequate output	15
16. STORAGE	16
16.1 Short duration (≤ 1 month)	16
16.2 Long duration (> 1 month)	16
17. SCRAPPING	16

1. PRESENTATION

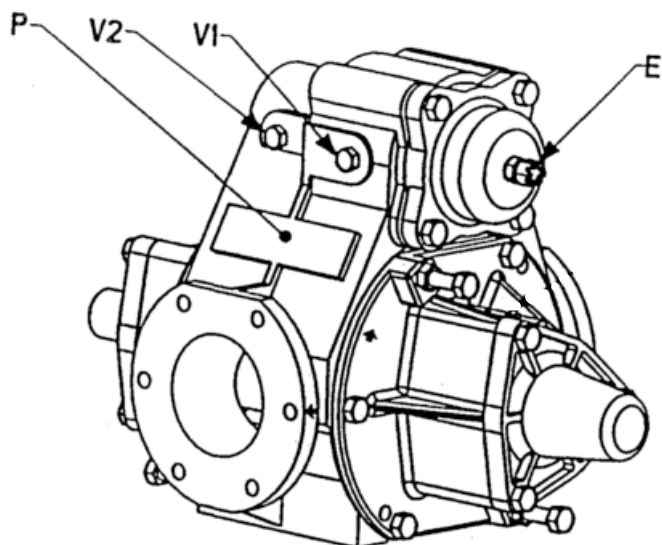

- E - Bypass adjustment
- P - Pump plate
- V1 - Drain plug-vacuum G1/4
- V2 - Drain plug-pressure G1/4

2. OPERATING LIMITS

	Speed range (rpm)	Flow rate pression (m³/h)		Max pressure (bar)	Required power (Kw)	
		CC8-80 F	CC8-100 F		CC8-80 F	CC8-100 F
Construction A Viscosity < 40 cSt	580 à 750	62	73	8	18,4	20
	580 à 1000	81	104	4	12	16

The pumps CC8-80 F and CC8-100 F can work at a pressure equal to 8 bar.

They are normally delivered with spring (4 or 8 bar) adjusted at 4 bar.

When requested, they can be delivered with a 8 bar spring adjusted at the maximum pressure of use.

Temperature range allowed : -20°C to +80°C

Products authorised : Clean petroleum product

Other products: Contact us

3. OVERALL DIMENSIONS

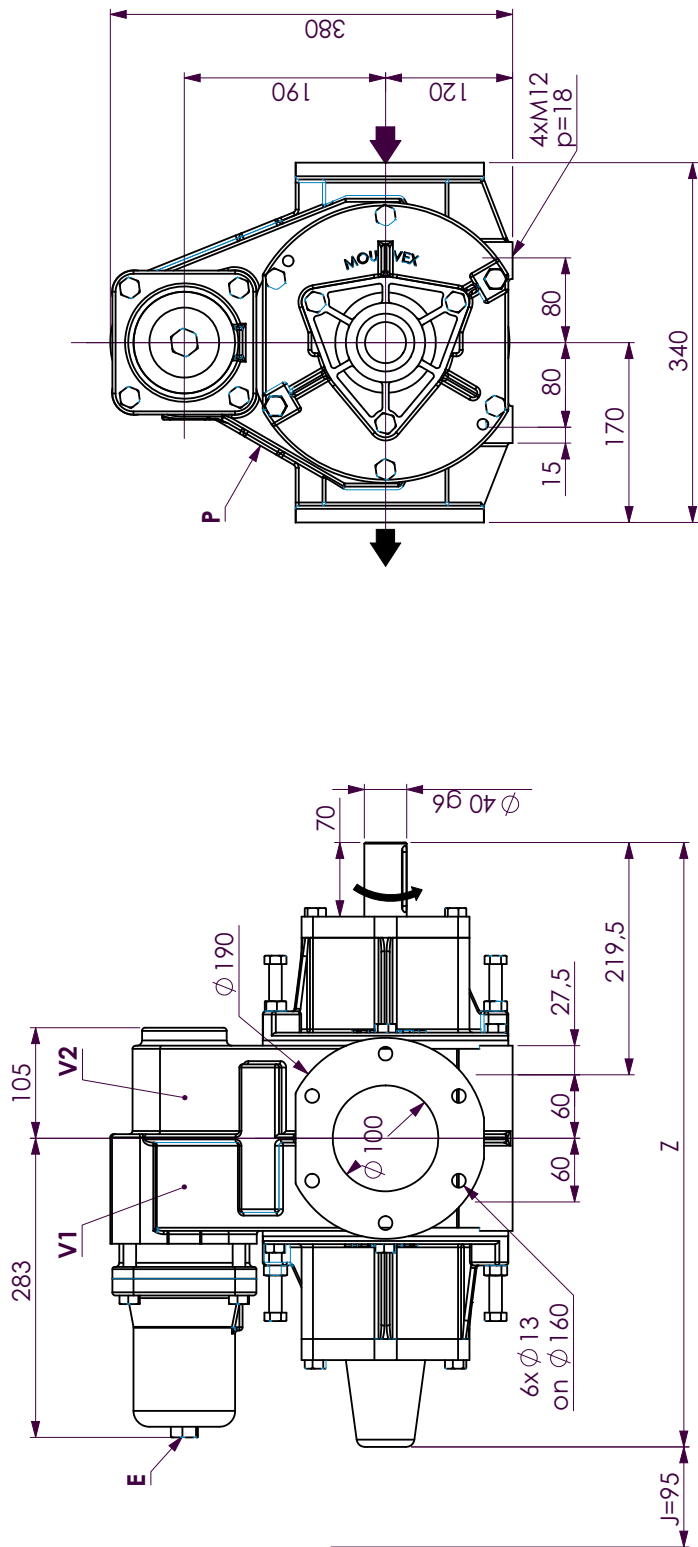

J - End plate dismounting
 Z - with shaft protector (standard) 572 mm - without shaft protector 562 mm

Weight : 94 kg

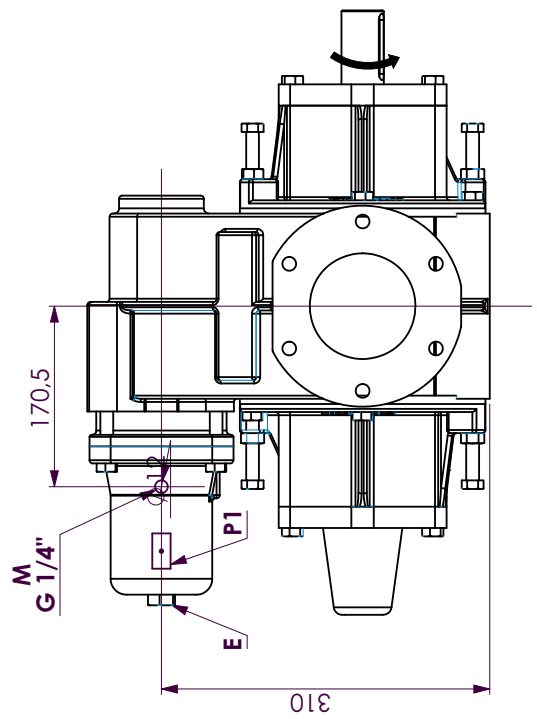

4. INSTALLATION

4.1 Choice of pump

To obtain the service expected from a MOUVEX pump, regarding both performance and longevity, it is vital that the type of pump, its speed and the materials used for its construction are determined as a function of the pump output, its installation and operating conditions.

You can contact our Technical Services at any time to ask for the information you require.

4.2 Direction of rotation

The pump rotates in one direction only. This is indicated by an arrow on the pump housing. However, the pump has both of shaft-ends led out and must be driven through one the other depending on the direction of rotation of the power take-off.

Because the pump rotates in one direction only, the positions of the suction and discharge ports are not be reversed (see arrows on housing). The safety bypass has not to be reversed.

4.3 Pump protection

It is essential to protect the pump against possible foreign matter by connecting a filter to the suction pipe (see Instructions 1011-G00 Filters PF).

4.4 Pipe diameter

In order to achieve the best usage conditions, it is important to take the following recommendations into account when it comes to pipe dimensions :

- The pipe diameter should be chosen as a function of pipe length and the flow rate and viscosity of the pumped liquid, so that any head loss remains within the permissible limits for the motor/pump unit. Therefore it is difficult to give general and precise directions. However, it is never a disadvantage to over-dimension pipe diameters, especially for the section on the inlet side.
- In the case of thin liquids and the piping on the discharge side, one can generally allow a diameter equal to that of the ports on the pump and a larger diameter for the piping on the inlet side, if the value for the inlet power of the pump is negative or especially high.
- In the case of viscous liquids, special care should be given to choosing pipe diameters. In fact, the variation in head loss is proportional to viscosity and inversely proportional to the diameter as power of 3. A slight reduction in the pipe diameter could have serious consequences for the operating conditions of the pump.

Our Technical Services are always available to provide you with precise data if you give them accurate information or, better still, the installation plans.

4.5 Piping assembly

In order to achieve the best usage conditions, it is important to take the following recommendations into account when it comes to fitting pipes :

- The location of the pump in the transfer or recycling circuit should always be determined so as to reduce the height and length of the piping as much as possible.
- Wherever possible, siphons and reverse slopes should be avoided in the inlet piping.
- Particular care needs to be taken with the sealing on the inlet side to prevent air entering.
- Pipe elbows must always have a large radius (more than 3 times the diameter of the pipes) and must not be mounted too close to the pump flanges (min. recommended distance : 10 times the diameter of the pipes), on both the inlet and discharge sides.
- The pipes are supported and aligned with the pump in such a way as to avoid putting stress on the pump flanges. Non-compliance with this instruction can lead to deformation of pump parts, misalignment of bearings and accelerated material wear, even causing parts to break.
- For ease of adjustment and checking, it is recommended that pressure tapping ports for pressure gauges/vacuum gauges be provided as close as possible to the pump's inlet ports (preferably, at a distance of less than 5 times the diameter of the piping).
- If the suction head is especially high or if you want to prevent the pipes emptying at shutdown, you can install a foot valve. It should have a large diameter so as not to generate additional head loss.
- We recommend placing valves as close as possible to the pump ports to avoid having to drain the entire system each time maintenance is carried out. These valves should have the same diameter as the pipes and preferably by full bore models.
- All these steps should be taken to prevent foreign bodies entering the pump (the use of a filter in the pump inlet pipe is strongly recommended).
- Before installing new pipes or tanks, be sure to clean them very carefully to remove any solder, rust, etc. which could be carried along with the water and cause excessive pump wear.
- The pipes should be designed to allow for thermal expansion/contraction (the use of flexible hoses or expansion loops is recommended).
- If the liquid may freeze or solidify, prepare for draining the piping by installing drain taps at the low points and air vents at the high points.

4.6 Bypass setting

The bypass must be set depending on the needs and the limitations of the installation.

5. DIRECT DRIVE BY MOTOR

5.1 Installation of units

	WARNING
BE CAREFUL WITH THE WEIGHT OF THE PARTS WHEN THEY ARE BEING REMOVED.	
The weight of the parts can be dangerous and may provoke bodily injuries or material damages.	

The correct seating of the pump is vital for its efficient operation and its longevity. The base must be flat, level and sufficiently resistant to absorb the stresses caused by the motor-driven pump without deformation (if it is made of concrete, it must comply with standard BAEL 91).

In the case where the unit is fastened by anchor lugs or bolts, it must be carefully wedged to prevent any deformation of the chassis when tightening the bolts. Deformation of the chassis will cause stress prejudicial to the pump and the drive device and put the coupling out of true alignment, thereby causing vibrations, noise and premature wear. Care must be taken so that the chassis is clear of the ground, apart from the base plates.

If the chassis is a one-piece unit in doubled plate, it is recommended that a horizontal clearance of about 50 cm be left between one section of the chassis and the other to allow access for fastening the nuts on the pump, reduction gearbox and motor. In all cases, the clearance around the motor-driven pump should all room for demounting the pump (for distances, refer to the dimension drawing at the start of the notice).

The chassis is equipped with a ground connection that must be used to protect people and equipment.

5.2 Alignment of motor/pump and reduction gearbox/pump shafts

	WARNING
OPERATION WITHOUT THE SHAFT PROTECTOR CAN CAUSE SERIOUS PERSONAL INJURY, MAJOR PROPERTY DAMAGE OR DEATH.	
Do not operate without guard in place.	

	WARNING
DISCONNECT THE ELECTRICITY SUPPLY BEFORE ANY MAINTENANCE OPERATION.	
Dangerous voltage. Can cause injury and death.	

The motor and pump shafts are accurately aligned at the factory before dispatch, but they should be checked carefully when received at the site and realigned if necessary. To align the coupling and the shaft, use a straight-edge to check the concentricity and thickness gauges for the angular misalignment.

The 3 figures below show the procedure in detail and the admissible deviations :

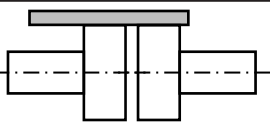
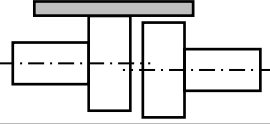
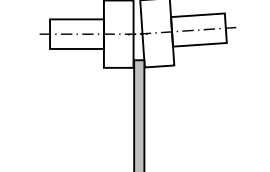
<i>Carry out the control at four points : at the top - at the bottom - left - right</i>	
	<i>Correct</i>
	<i>Bad alignment</i>
	<i>Angular fault (maximum : 1°)</i>

Controlling the alignment at each stage of the installation is important to be sure that none of the following procedures has generated stresses on the unit or the pump :

- after fastening on the foundations.
- after fastening the pipes.
- after the pump has been operated at the normal operating temperature.



REMINDER :

You cannot rely on the coupling to compensate for misalignment.

NEVER START A UNIT IF THE COUPLING ALIGNMENT IS INCORRECT. THIS WILL RENDER OUR WARRANTY INVALID.

5. DIRECT DRIVE BY MOTOR (continued)



5.3 Electric motors



	WARNING
	<p>DISCONNECT THE ELECTRICITY SUPPLY BEFORE ANY MAINTENANCE OPERATION.</p>
<p>Dangerous voltage. Can cause injury and death.</p>	



Check that the supply voltage matches the indications on the motor rating plate.

Comply with the wiring diagram, make sure the wires are rated for the power and take care with the contacts, which must be thoroughly tightened. The motors must be protected by appropriate circuit breakers and fuses. Connect the regulatory ground connections.

Check the direction of rotation.

	WARNING
	<p>TAKE ALL NECESSARY MEASURES TO RENDER ANY START-UP, EVEN ACCIDENTAL, OF THE PUMP DURING THE WORK IMPOSSIBLE.</p>
<p>Any unforeseen start-up can cause serious injuries or important material damages.</p>	

	WARNING
	<p>PUMPS OPERATING AGAINST A CLOSED VALVE CAN CAUSE SYSTEM FAILURE, PERSONAL INJURY AND PROPERTY DAMAGE.</p>
<p>Hazardous pressure can cause personal injury or property damage.</p>	

	WARNING
	<p>OPERATION WITHOUT THE SHAFT PROTECTOR CAN CAUSE SERIOUS PERSONAL INJURY, MAJOR PROPERTY DAMAGE OR DEATH.</p>
<p>Do not operate without guard in place.</p>	

This check should be done with no liquid being pumped, and both the inlet and discharge circuits vented to avoid generating unexpected pressure (on the inlet side, for example). This will avoid damaging either the pump or the system.



Start the pump empty to check that the connections are good and that the direction of rotation corresponds to the system intake and discharge directions. If it is necessary to reverse the direction of rotation, follow the instructions below :

Three-phase motor : switch any 2 current input wires.

Bi-phase motor : switch two same phase wires.

Single-phase motor : follow the instructions on the notice supplied with the motor.

5.4 Diesel engines drive

	CAUTION
	<p>THE SURFACES OF THE PUMP CAN BE AT A TEMPERATURE LIABLE TO CAUSE INJURY OR SEVERE DAMAGE.</p>
<p>Excessive temperature- can cause injury or severe damage.</p>	

Do not forget that these engines are not reversible. It is therefore vital to carefully check the inlet and outlet sides of the pump before connecting the pump unit to the piping.

The use of diesel engines drive is now well known. Nevertheless, we strongly recommend that you carefully read the technical manuals concerning them.



6. DRIVE BY POWER TAKE OFF

Refer to Instructions NT 1010-B00 CC8 CC10 CC20 PUMPS DRIVEN BY POWER TAKE OFF.

7. USE



The operator should remain nearby the equipment throughout the use to ensure the proper functioning of the system.



7.1 Pumping hot liquids

 CAUTION	<p>THE SURFACES OF THE PUMP CAN BE AT A TEMPERATURE LIABLE TO CAUSE INJURY OR SEVERE DAMAGE.</p>
	
<p>Excessive temperature- can cause injury or severe damage.</p>	

When pumping hot liquids, make your you retighten screws and bolts after starting for the first time in order to compensate for contraction.

7.2 Pump full of liquid when stopped

 WARNING	<p>FAILURE TO INSTALL ADEQUATELY SIZED PRESSURE RELIEF VALVE(S) CAN CAUSE PROPERTY DAMAGE, PERSONAL INJURY OR DEATH.</p>
	
<p>Hazardous pressure can cause personal injury or property damage.</p>	



 WARNING	<p>IF PUMPING HAZARDOUS OR TOXIC FLUIDS, THE SYSTEM MUST BE FLUSHED PRIOR TO PERFORMING ANY SERVICE OPERATION.</p>
	
<p>Toxic or hazardous fluids can cause serious injury.</p>	



If the pump circuit is to be located between valves and/or a non-return valve, you need to take account of the variations in temperature that can lead to contraction of the liquid in the circuit. In this case, you need to provide some means of compensating for the contraction. A discharge valve may be sufficient. The opening pressure for this valve should be compatible with the permitted pressure for the other components in the circuit.

It is also advisable to fit a discharge device to allow the circuit to be completely emptied for any maintenance work.

In the case of liquids containing particles settling on shut-down, it is necessary to make sure the consistency of the deposit will not impede restarting the pump.

7.3 Starting-up the pump

 WARNING	<p>FAILURE TO RELIEVE SYSTEM PRESSURE PRIOR TO PERFORMING PUMP SERVICE OR MAINTENANCE CAN CAUSE PERSONAL INJURY OR PROPERTY DAMAGE.</p>
	
<p>Hazardous pressure can cause personal injury or property damage.</p>	

 WARNING	<p>OPERATION WITHOUT THE SHAFT PROTECTOR CAN CAUSE SERIOUS PERSONAL INJURY, MAJOR PROPERTY DAMAGE OR DEATH.</p>
	
<p>Do not operate without guard in place.</p>	

Before starting the pump, make sure that the following conditions are met :

- The circuit should be in one of its pumping configurations, with the appropriate valves open, especially on the intake side.
- For products requiring heating, they must be brought to their pumping temperature before starting the pump.

7.4 Running without liquid in the pump

MOUVEX CC8 pumps can run without liquid in the pump for 5 minutes without causing damage, in particular during pump priming.

7.5 Using of the pump with a valve closed on the discharge line

The using of the pump with a valve closed on the discharge line implies the liquid is not renewed which generates a heating up. In consequence, that operating way must not exceed 3 minutes.

7.6 Shutting down the pump

When shutting down the pump, we recommend waiting for it to stop completely before closing the valves, especially the inlet valve.

7. USE (continued)

7.7 Protection from frost

If there is a risk of frost with the product contained in the pump, it is necessary to drain the body after each use as follows :

- Check there is no valve closed on the discharge side as well potential counter pressure due to a check valve or liquid remaining inside a vertical pipe.
- Rotate the pump.
- Create an air entering on the suction side during 30 seconds.
- Stop the pump and make sure no liquid is coming back > pump has to be closed.

7.8 Restarting

Follow the standard start-up procedure for the pump/ motor-driven pump, as well as the instructions below.

Turn the pump by hand to make sure the parts move freely.

Remove the bypass and inspect the parts and make sure they move freely.

8. NECESSARY TOOLS

- Flat wrenches 19 - 24
- Circlip opening pliers
- Screwdriver

Makeup torques :

- M1284 Nm
- M1047 Nm
- M 823 Nm
- M 610 Nm

9. DISMANTLING - REASSEMBLY

WARNING	DISCONNECT THE ELECTRICITY SUPPLY BEFORE ANY MAINTENANCE OPERATION.
Dangerous voltage. Can cause injury and death.	

WARNING	DISCONNECTING THE FLUID OR PRESSURE CONTAINMENT COMPONENTS DURING PUMP OPERATION CAN CAUSE SERIOUS PERSONAL INJURY, DEATH OR MAJOR PROPERTY DAMAGE.
Hazardous pressure can cause personal injury or property damage.	

WARNING	FAILURE TO RELEASE ALL SYSTEM AIR AND WHEN EQUIPPED, HYDRAULIC PRESSURE, CAN CAUSE PROPERTY DAMAGE, PERSONAL INJURY OR DEATH.
Hazardous pressure can cause personal injury or property damage.	

WARNING	IF PUMPING HAZARDOUS OR TOXIC FLUIDS, THE SYSTEM MUST BE FLUSHED PRIOR TO PERFORMING ANY SERVICE OPERATION.
Hazardous or toxic fluids can cause serious injury.	

WARNING	BE CAREFUL WITH THE WEIGHT OF THE PARTS WHEN THEY ARE BEING REMOVED.
The weight of the parts can be dangerous and may provoke bodily injuries or material damages.	

CAUTION	THE PUMP LUBRICANT IS VERY SLIPPERY AND MAY CAUSE SERIOUS INJURY. ANY SPILLS MUST BE CLEANED UP.
Slippery lubricant. Spills should be cleaned up.	

CAUTION	THE SURFACES OF THE PUMP CAN BE AT A TEMPERATURE LIABLE TO CAUSE INJURY OR SEVERE DAMAGE.
Excessive temperature can cause injury or severe damage.	

WARNING	TAKE ALL NECESSARY MEASURES TO RENDER ANY START-UP, EVEN ACCIDENTAL, OF THE PUMP DURING THE WORK IMPOSSIBLE.
Any unforeseen start-up can cause serious injuries or important material damages.	

Before any dismantling, make sure that the pump has been drained and take all the necessary precautions to prevent it from starting up. The pump must not start up, even accidentally.

9. DISMANTLING - REASSEMBLY (suite)

9.1 Side opposite to drive system

Dismantling

Unscrew the screws **723** and remove the shaft protector **712** and the o'ring **714**.

Remove circlip **537**.

Carefully clean the shaft end (remove any trace of paint, oxidation, burrs...).

Unscrew the 4 screws **410**.

Unscrew the 4 screws **411** fitted with their nut **412** and place them in the 2 tapped holes T.

Screw up the 2 screws at the same time so that the end-plate is gradually released along the centre line.

When the end-plate is free on the shaft, hold it by hand supporting it.

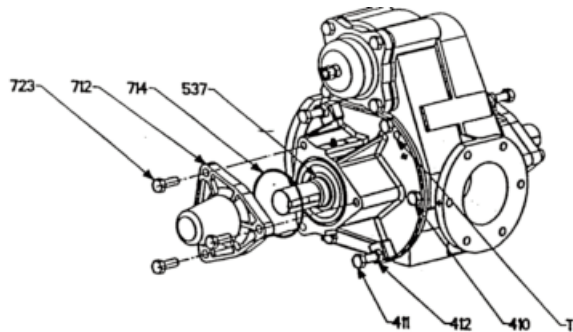

Reassembly

Replace the shaft protector **712** on the end plate **401** with screws **723**.

Lubricate the shaft **501** slightly.

Make sure that the end-plate o'ring **403** is correctly positioned, check it and change it if necessary and paste it with an appropriate grease to fix it in the groove.

Position horizontally the mechanical seal lugs perpendicularly to drainage ports L.

Rotate the rotor to orientate the mechanical seal drive notches in horizontal plane.

Position the end plate **401** on the shaft and approach it as far as possible by hand.

Rotate the end plate so as to position one of the drainage port L pointing down.

Check the mechanical seal lugs are well in front of the rotor notches.

Place the 2 screws **411** with their nuts **412** and finish fitting the end-plate, screwing the 2 nuts **412** gradually.

Screw the 2 screws **411** with their nuts **412** in the bosses.

Replace the screws **410**.

Remove the cover **712**.

Replace the circlip **537**.

Replace the shaft protector **712** with its o'ring **714** after check condition of seal.

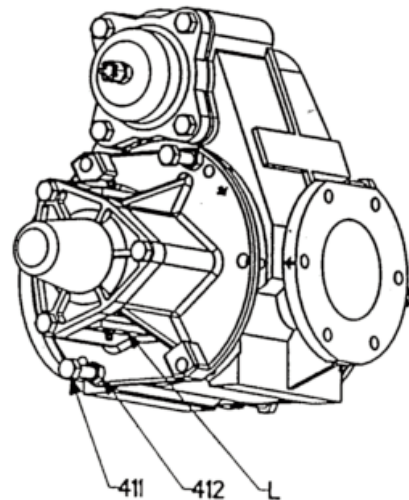
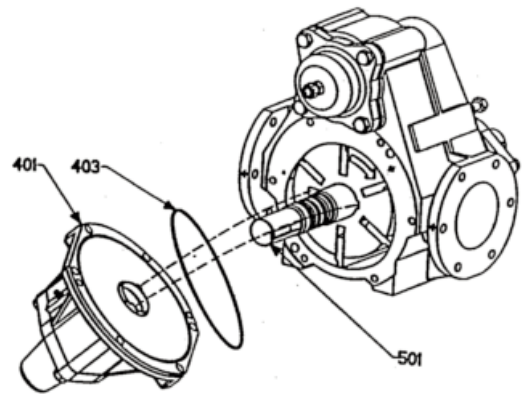

9.2 Drive side

Dismantling

Uncouple the pump by removing the coupling.

Remove the key **508**.

Carefully clean the shaft end (remove any trace of paint, oxidation, burrs...).

Unscrew the screws **723**, remove the cover **705** with its o'ring **714** taking care not damaging lip seal **707**.

Remove the circlip **537**.

Then operate in a identical way to dismantling on side opposite to drive system.

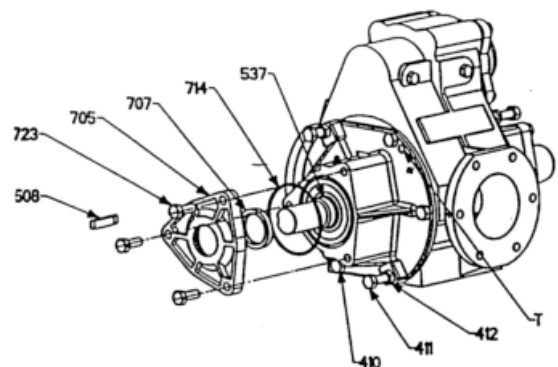

9. DISMANTLING - REASSEMBLY (suite)

Reassembly

Replace the cover **705** on the end plate **401** with screws **723**.

Lubricate the shaft **501** slightly.

Make sure that the end-plate o'ring **403** is correctly positioned, check it and change it if necessary and paste it with an appropriate grease to fix it in the groove.

Position horizontally the mechanical seal lugs perpendicularly to drainage ports L.

Rotate the rotor to orientate the mechanical seal drive notches in horizontal plane.

Position the end plate **401** on the shaft and approach it as far as possible by hand.

Rotate the end plate so as to position one of the drainage port L pointing down.

Check the mechanical seal lugs are well in front of the rotor notches.

Place the 2 screws **411** with their nuts **412** and finish fitting the end-plate, screwing the 2 nuts **412** gradually.

Screw the 2 screws **411** with their nuts **412** in the bosses.

Replace the screws **410**.

Remove the cover **705**.

Replace the circlip **537**.

Replace the cover **705** with its o'rings **714** and **707** after check condition of seals.

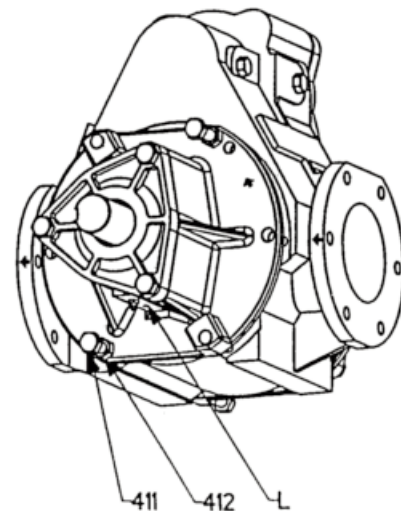
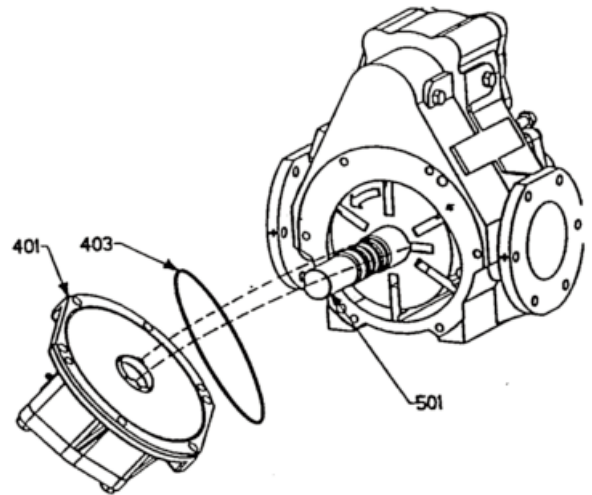

9.3 Assembly of flange for hydraulic trunk

Refer to Instructions NT 1010-K00 ASSEMBLY OF FLANGE FOR HYDRAULIC TRUNK ON PUMP CC8 CC10.

10. CHANGING THE VANES

Dismantle the pump from the side opposite to drive system.

Remove a vane **317**.

Check for wear (see § MAINTENANCE).

If vane wear is abnormal, check surface condition of body and of end-plate faces.

Refit the vane (new if necessary) respecting the direction of assembly.

Proceed so on for each vane.

Reassemble the pump and check that it rotates freely when turned by hand.

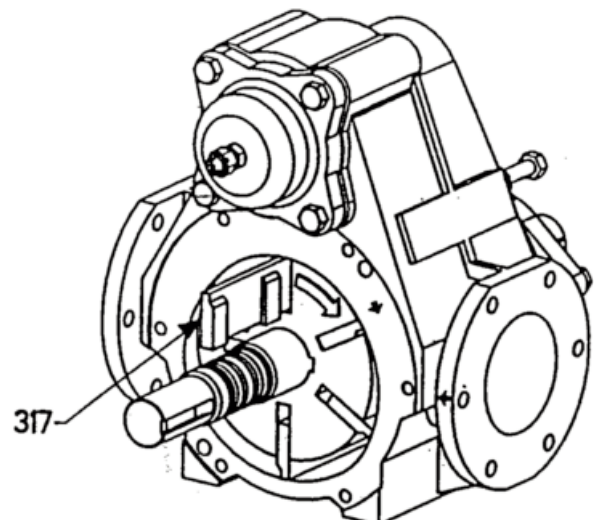

11. CHANGING MECHANICAL SEAL AND BALL BEARINGS

Dismantling

Remove the end-plate on the appropriate side (see corresponding §).

Remove the end-plate on its machined side taking care not to damage the mechanical seal drive lugs.

Remove parts.

Reassembly

IMPORTANT :

Lubricate the bore which takes the roller bearings.

Do not lubricate the ball bearings, the pump is equipped with ball bearings lubricated for life.

Make sure that the o-rings **605-613** and the mechanical seal are in good condition. Change them if necessary.

Place the o-ring **605** in the end plate **401**.

Make sure that the o-ring **613** is correctly positioned in the mechanical seal **630**.

Refit the mechanical seal **630** (a new one if necessary), in the end plate **401**, supported on the o-ring **605**.

Place the protection ring **733** so as to be supported on the mechanical seal **630**.

Place a bearing **703** supported on the protection ring **733**.

Position the spacer **734** with its aperture opposite a grease nipple **708** (if present).

Place the second bearing **703** so it is supported on the spacer **734**.

Refit the end plate by following the previous instructions.

12. MECHANICAL BYPASS

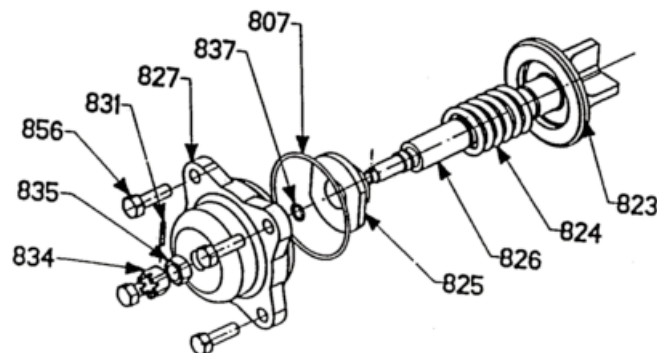

Dismantling

Set bypass at minimal pressure by unscrewing the lock-nut **835**.

Take care to count the number of rotations by unscrewing fully the nut **834** so as to be able to reset bypass at initial pressure setting.

Unscrew the 3 screws **856** of the bypass cap **827**.

Remove spring **824**.

Remove the valve **823** by pulling its cylindrical section with the fingers.

Check condition of bypass.

Reassembly

Clean parts before reassembly.

Place the valve **823** in the body pump.

Place the spring **824**.

Check condition of o-ring **807** of bypass cap **827**.

Screw the 3 screws **856**.

Set bypass at desired pressure setting by tightening nut **834** with the same number of rotations as counted during dismantling.

13. PNEUMATIC BYPASS

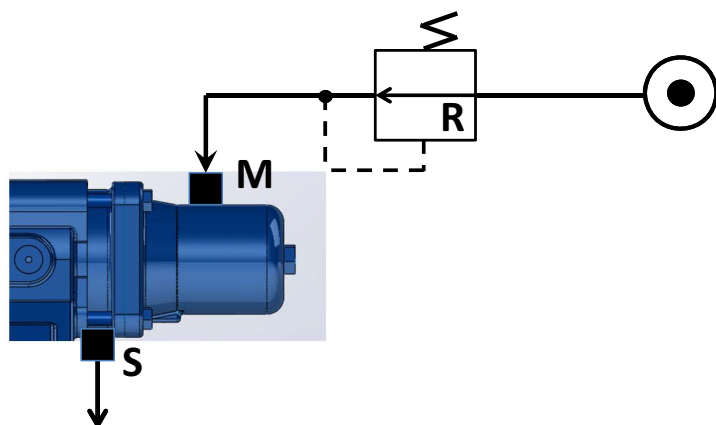

E	Bypass adjustment
R	Air pressure limiter to be set in order to not over pressure the pump (8 bar maxi)
M	Pneumatic bypass port
P1	Identification plate
S	Air bypass exhaust to be connected to a vertical pipe to avoid any water entering

13.1 Dismantling

Disconnect the air inlet.

Remove the screws **805**.

Remove the assembly, if the valve **823** remains in the casing, remove it by pulling its cylindrical section with the fingers.

Before opening the bypass, check the waterproofness as follow : maintain **841** (adjustable bypass) or **801** (no adjustable bypass) with **802** thanks to 4 bolts (not provided) and fit the bypass in a vice in order to avoid any separation with the plate **847**.

13.2 Membrane and seals **804, 815, 837** control (adjustable bypass) :

Connect air supply to (M), Pressure <4 bar going through a valve and a pressure gauge. Close the valve, disconnect the air inlet, notice the pressure at the gauge, wait for 30s and check the gauge pressure is stable. If not, locate the leak with liquid (water + soap).

Check the quadring **838**, the O-ring **839**, connect the air supply to the port (S) and do the same test.

In some cases, a light leak between the membrane **813** and the plate **802** is acceptable.

13.3 Access to the membrane

Unblock the nut **835** and release the spring **842** by losing at the maximum the nut **834**, notice the turn number (adjustable bypass).

Remove the screws **803**.

Separate the items **841, 802** and remove the O-ring **804**.

Remove the assembly membrane pusher.

Maintain the pusher **811** in a vice equipped with protections to avoid any damage.

Lose the nut **814** and remove the washer **815**.

Remove the membrane washer **812** and the membrane **813**.

Clean the items and change them if requested, the membrane and the seals **807, 838, 804** and **837**.

13.4 Reassembling

Reassemble in the reverse order in taking care of putting the membrane with the mark EFFBE on the side of **820**.

Redo the test done previously.

Set the bypass by screwing the nut **834** with the same turn numbers noticed.

14. MAINTENANCE

14.1 Lubrication

Ball bearing are lubricated for life and don't require any grease adding.

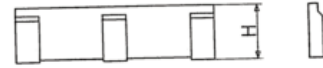

14.2 Inspection of the vanes

Check the conditions of the vanes every 700 operating hours.

Pump	CC8-80/100
Original height h	44
Change when $h < \grave{a}$	41

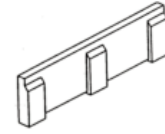

14.3 Cleaning the filter

The pump should always be protected against possible foreign matter by means of a filter connected into the suction pipe.

Check the cleanliness of the filter mesh from time to time as a partly clogged filter could starve the pump and reduce its output.

To clean the filter, remove the meshes and clean them carefully. Before refitting them, drain the filter by removing the drain plug, then rinse it thoroughly.

15. TROUBLESHOOTING

CAUTION :
OBSERVE ALL SAFETY WARNINGS CONTAINED IN THIS MANUAL.

15.1 Abnormal noise

Main causes :

- Excessive suction vacuum, due to :
 - a pipe, accessories (valves, filter...) which are either clogged or of insufficient diameter,
 - excessive suction head (e.g. during liquid transfer operations),
 - a viscosity or vapour tension too high for the system to cope with (e.g. when changing the product to be pumped).
- Overly high rotation speed for the liquid being pumped.
- Pump damaged
 - as a result of binding due to :
 - an excessively high rotation speed,
 - failure to release the drive when pumping is ended,
 - sudden engagement of the drive,
 - an unduly high pulling force on the shaft, leading to a damaged ball-bearing and shaft.
 - as a result of foreign matter, due to :
 - the absence of a filter or inefficient cleaning,
 - the absence of a basket (failure to replace it after cleaning),
 - solder or rust particles remaining in the pipe between the filter and the pump.
- Bypass valve hammer on its seat due to incorrect adjustment of the spring's tension.

15.2 Leaking seal

Main causes :

- Abnormal pulling force on the shaft, leading to a damaged bearing and seal,
- Displacement of the shaft when mounting an unduly tight coupling making the seal unserviceable,
- Seal damage caused by pumping an aggressive product,
- Ball-bearing lubricated excessively or at unduly high pressure.



15.3 Inadequate output

Main causes :

- Excessive suction vacuum (see § Abnormal noise - Excessive suction vacuum),
- Bypass setting too low,
- Air leaking in at suction end,
- Discharge pipe diameter too small,
- Speed of rotation too low,
- Bypass valve not closing properly due to foreign matters on valve seat or because the valve lifting wheel (in the case of pumps fitted with one) has not been returned to its initial position after use,
- Pump damaged (see § Abnormal noise - Pump damaged due to passage of foreign matter).

16. STORAGE

16.1 Short duration (≤ 1 month)

 WARNING	IF PUMPING HAZARDOUS OR TOXIC FLUIDS, THE SYSTEM MUST BE FLUSHED PRIOR TO PERFORMING ANY SERVICE OPERATION.
	
Toxic or hazardous fluids can cause serious injury.	

MOUVEX pumps and motor-driven pumps are well lubricated when delivered to protect the internal parts during brief storage in a building where :

- the temperature remains between 10°C and 50°C.
- the relative humidity does not exceed 60%.
- exposure to vibration is limited (maximum movement : 0,05 mm).
- pump is stored in an area sheltered from bad weather and sun.

16.2 Long duration (> 1 month)

We recommend the following procedure for longer periods of storage :

The recommendations from the manufacturer should be followed if the pump is stored with its gear motor.

Pump ports should be filled with a non-corrosive liquid that it compatible with the pump components in order to prevent corrosion.

Unpainted external surfaces of the pump (e.g. shafts, couplings, etc.) should be covered in some form of anti-corrosion protection.

The bearing should be greased. If the pump is to be stored for more than three years, the grease should be replaced every three years to prevent it degrading.

The best storage conditions are inside a building that meets the conditions set out above.

If inside storage is not possible, the materials should be covered to prevent direct exposure to sun and bad weather. This protection should also prevent condensation.

It is recommended to turn the pump by hand every two months to distribute the lubricant around the interior. Items should then be placed where there is no risk of damage if they are moved slightly by vibrations.

17. SCRAPPING

The pump must be scrapped in compliance with the regulations in force.

During this operation, particular care must be paid to the drainage stages of the pump (pumped product).