

PS810 BRAHMA METAL PUMP

51 mm (2") Pump
Maximum Flow Rate:
640 lpm (169 gpm)

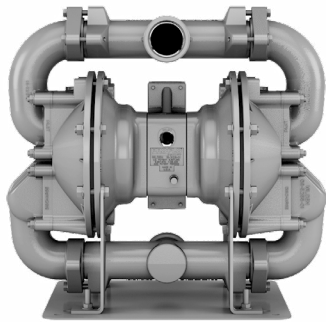

PS810 METAL

DIMENSIONAL DRAWING

PS810 Metal

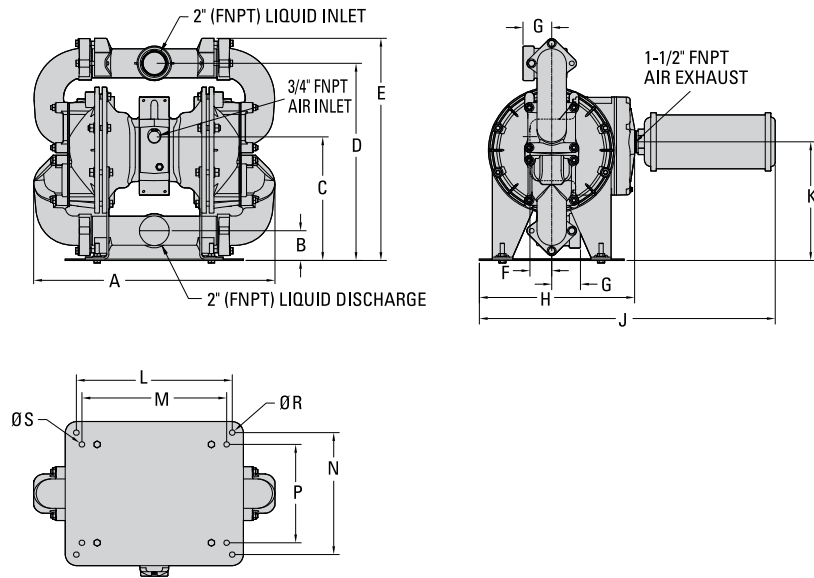

DIMENSIONS

ITEM	METRIC (mm)	STANDARD (inch)
A	550	21.7
B	68	2.7
C	283	11.1
D	451	17.8
E	509	20.0
F	50	2.0
G	66	2.6
H	354	13.9
J	680	26.7
K	272	10.7
L	356	14.0
M	330	13.0
N	279	11.0
P	226	8.9
R	13	0.5
S	13	0.5

LW0281 REV. A

PUMP DATA

Specifications:

Ship Weight..... Aluminum 37 kg (81 lb)
 Ductile Iron 57 kg (125 lb)
 Air Inlet 19 mm (3/4")
 Liquid Inlet..... 51 mm (2")
 Liquid Outlet..... 51 mm (2")

PS810 BRAHMA METAL PUMP

PERFORMANCE

PS810 METAL RUBBER-FITTED

Max. Flow Rate.....640 lpm (169 gpm)
 Max. Inlet Pressure8.6 bar (125 psig)
 Max. Solids Passage.....51 mm (2")
 Max. Suction Lift7.4 m Dry (24.3')
 9.0 m Wet (29.5')

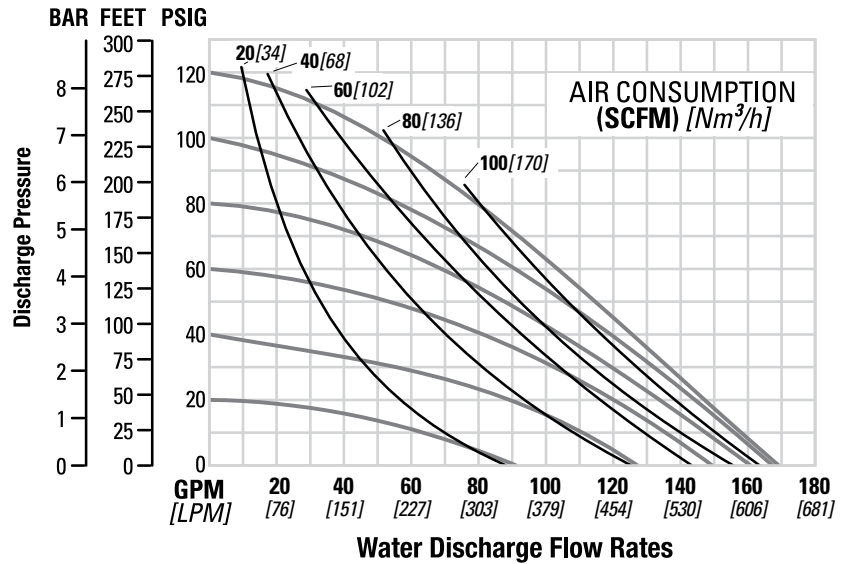

PS810 METAL CHEM-FUSE IPD WIL-FLEX® FITTED

Max. Flow Rate.....640 lpm (169 gpm)
 Max. Inlet Pressure8.6 bar (125 psig)
 Max. Solids Passage.....51 mm (2")
 Max. Suction Lift7.7 m Dry (25.2')
 9.0 m Wet (29.5')

