

## PS1510 BRAHMA METAL PUMP

**76 mm (3") Pump**  
**Maximum Flow Rate:**  
**882 lpm (233 gpm)**

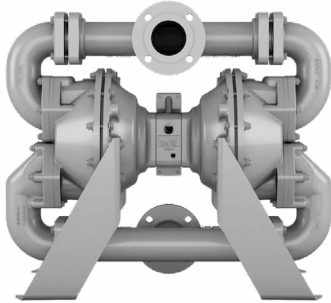

**PS1510 METAL**

### DIMENSIONAL DRAWING

#### PS1510 Metal

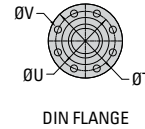
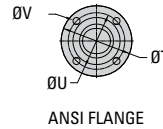
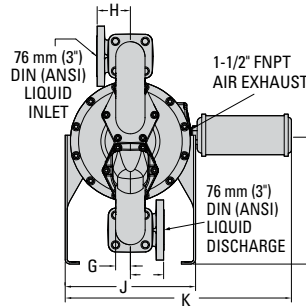
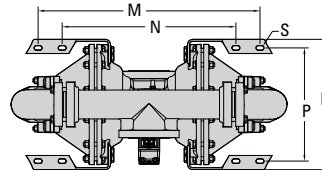
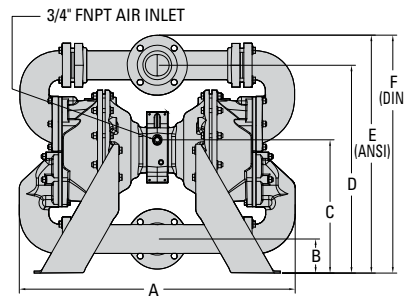

### DIMENSIONS

ITEM	METRIC (mm)	STANDARD (inch)
A	874	34.4
B	107	4.2
C	422	16.6
D	658	25.9
E	754	29.7
F	757	29.8
G	46	1.8
H	104	4.1
J	411	16.2
K	716	28.2
L	401	15.8
M	704	27.7
N	551	21.7
P	358	14.1
R	411	16.2
S	8.0	0.3
	<b>DIN (mm)</b>	<b>ANSI (inch)</b>
T	200 DIA.	7.5 DIA.
U	160 DIA.	6.0 DIA.
V	18 DIA.	0.8 DIA.

LW0284 REV. B

### PUMP DATA

**Specifications:**

Ship Weight.....Aluminum 81 kg (179 lb)

Ductile Iron 159 kg (350 lb)

Air Inlet..... 19 mm (3/4")

Liquid Inlet..... 76 mm (3")

Liquid Outlet..... 76 mm (3")

**PS1510 BRAHMA METAL PUMP**

**PERFORMANCE**

**PS1510 METAL RUBBER-FITTED**

Max. Flow Rate.....882 lpm (233 gpm)  
 Max. Inlet Pressure .....8.6 bar (125 psig)  
 Max. Solids Passage.....76 mm (3")  
 Max. Suction Lift .....7.1 m Dry (23.3')  
   9.0 m Wet (29.5')

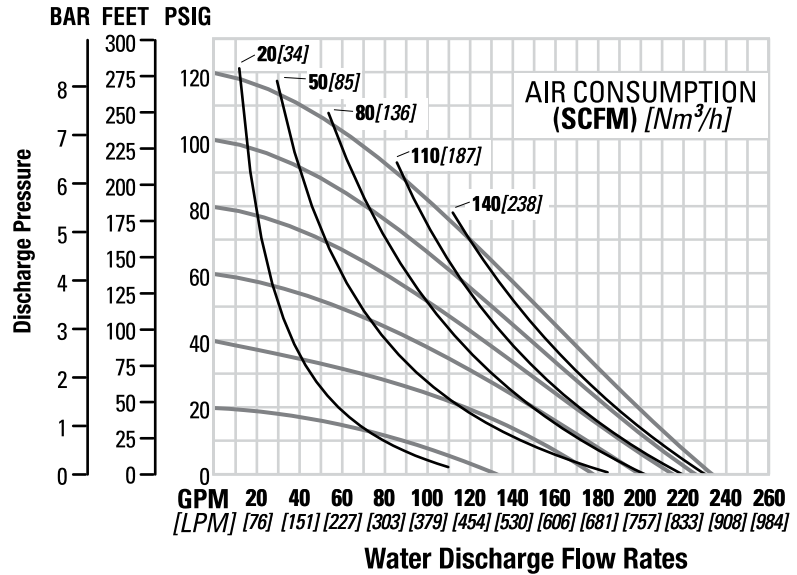

**PS1510 METAL CHEM-FUSE IPD WIL-FLEX® FITTED**

Max. Flow Rate.....882 lpm (233 gpm)  
 Max. Inlet Pressure .....8.6 bar (125 psig)  
 Max. Solids Passage.....76 mm (3")  
 Max. Suction Lift .....7.3 m Dry (23.9')  
   9.0 m Wet (29.5')

