

P2/PX2

Original™ Series **METAL** Pumps

EOM

Engineering
Operation &
Maintenance

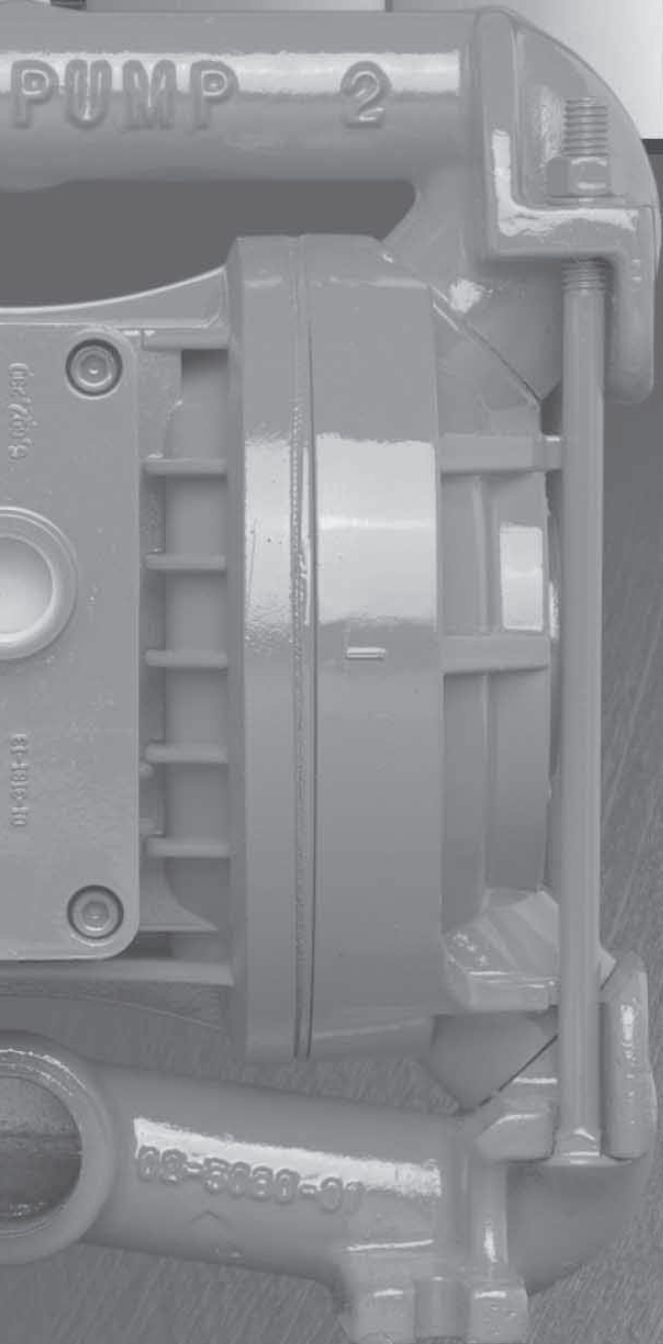

Simplify your process

PROFLO[®]
PROGRESSIVE PUMP TECHNOLOGY

PROFLO[™]X
PROGRESSIVE PUMP TECHNOLOGY

WILDEN

A **DOVER** COMPANY

CE

WIL-10182-E-01

TABLE OF CONTENTS

SECTION 1 CAUTIONS—READ FIRST!1

SECTION 2 WILDEN PUMP DESIGNATION SYSTEM2

SECTION 3 HOW IT WORKS—PUMP & AIR DISTRIBUTION SYSTEM3

SECTION 4 DIMENSIONAL DRAWINGS4

SECTION 5 PERFORMANCE

 A. P2 Metal Performance Curves

 Rubber-Fitted6

 TPE-Fitted6

 PTFE-Fitted7

 B. Suction Lift Curves7

SECTION 6 SUGGESTED INSTALLATION, OPERATION & TROUBLESHOOTING8

SECTION 7 DISASSEMBLY / REASSEMBLY11

 Air Valve / Center Section Disassembly13

 Reassembly Hints & Tips15

SECTION 8 EXPLODED VIEW AND PARTS LISTING

 PX2 Metal

 Rubber/TPE-Fitted16

 PTFE-Fitted18

 P2 Metal

 Rubber/TPE-Fitted20

 PTFE-Fitted22

SECTION 9 ELASTOMER OPTIONS24

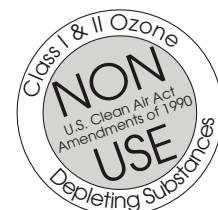

CAUTIONS — READ FIRST!

TEMPERATURE LIMITS:

Polypropylene	0°C to 79.4°C	32°F to 175°F
Acetal	-28.9°C to 65.6°C	-20°F to 150°F
Neoprene	-17.8°C to 93.3°C	0°F to 200°F
Buna-N	-12.2°C to 82.2°C	10°F to 180°F
EPDM	-51.1°C to 137.8°C	-60°F to 280°F
Viton [®]	-40°C to 176.7°C	-40°F to 350°F
Wil-Flex [™]	-40°C to 107.2°C	-40°F to 225°F
Polyurethane	-12.2°C to 65.6°C	10°F to 150°F
Saniflex [™]	-28.9°C to 104.4°C	-20°F to 220°F
PTFE	4.4°C to 148.9°C	40°F to 300°F



CAUTION: When choosing pump materials, be sure to check the temperature limits for all wetted components. Example: Viton[®] has a maximum limit of 176.7°C (350°F) but Acetal has a maximum limit of only 65.6°C (150°F).



CAUTION: Maximum temperature limits are based upon mechanical stress only. Certain chemicals will significantly reduce maximum safe operating temperatures. Consult engineering guide for chemical compatibility and temperature limits.



CAUTION: Always wear safety glasses when operating pump. If diaphragm rupture occurs, material being pumped may be forced out air exhaust.



WARNING: Prevention of static sparking — If static sparking occurs, fire or explosion could result. Pump, valves, and containers must be properly grounded when handling flammable fluids and whenever discharge of static electricity is a hazard.



CAUTION: Do not exceed 8.6 bar (125 psig) air supply pressure.



CAUTION: Before any maintenance or repair is attempted, the compressed air line to the pump should be disconnected and all air pressure allowed to bleed from pump. Disconnect all intake, discharge and air lines. Drain the pump by turning it upside down and allowing any fluid to flow into a suitable container.



CAUTION: Blow out air line for 10 to 20 seconds before attaching to pump to make sure all pipe line debris is clear. Use an in-line air filter. A 5μ (micron) air filter is recommended.



NOTE: Tighten all hardware prior to installation. Fittings may loosen during transportation.



NOTE: When installing PTFE diaphragms, it is important to tighten outer pistons simultaneously (turning in opposite directions) to ensure tight fit.



NOTE: Before starting disassembly, mark a line from each liquid chamber to its corresponding air chamber. This line will assist in proper alignment during reassembly.



CAUTION: Verify the chemical compatibility of the process and cleaning fluid to the pump's component materials in the Chemical Resistance Guide (see E4).



CAUTION: Do not over-tighten the air inlet reducer bushing. Too much torque on the reducer may damage either the reducer bushing or center section. Do not exceed 10.9 N•m (8 ft-lbs).



CAUTION: Do not exceed the maximum torque specification of 13.0 N•m (115 in-lbs) on the liquid chamber to air chamber fasteners on the P2 Bolted configuration.

WILDEN PUMP DESIGNATION SYSTEM

P2/PX2 METAL

**25 mm (1") Pump
Maximum Flow Rate:
170 lpm (45 gpm)**

LEGEND

P2 / XXXXX / XXX / XX / XXX / XXXX

MODEL

WETTED PARTS & OUTER PISTON

AIR VALVE
CENTER SECTION

DIAPHRAGMS

VALVE BALLS

O-RINGS
VALVE SEAT

SPECIALTY
CODE
(if applicable)

MATERIAL CODES

MODEL

P2 = PRO-FLO®
PX2 = PRO-FLO X™
XPX2 = ATEX PRO-FLO X™

WETTED PARTS & OUTER PISTON

AA = ALUMINUM /
ALUMINUM
AZ = ALUMINUM / NO
PISTON
HH = ALLOY C / ALLOY C
HZ = ALLOY C / NO PISTON
SS = STAINLESS STEEL /
STAINLESS STEEL
SZ = STAINLESS STEEL /
NO PISTON

CENTER SECTION

LL = ACETAL (PRO-FLO® ONLY)
PP = POLYPROPYLENE
(PRO-FLO® ONLY)
A = ALUMINUM
(PRO-FLO X™ ONLY)

AIR VALVE

L = ACETAL (PRO-FLO® ONLY)
P = POLYPROPYLENE
(PRO-FLO® ONLY)
A = ALUMINUM
(PRO-FLO X™ ONLY)

DIAPHRAGMS

BNS = BUNA-N (Red Dot)
EPS = EPDM (Blue Dot)
FSS= SANIFLEX™
[Hytrel® (Cream)]
NES = NEOPRENE (Green Dot)
PUS = POLYURETHANE (Clear)
TEU = PTFE W/EPDM BACK-UP
TNL = PTFE W/NEOPRENE
BACK-UP O-RING, IPD (White)
TSU = PTFE W/SANIFLEX™
BACK-UP (White)
VTS = VITON® (White Dot)
WFS = WIL-FLEX™
XBS = CONDUCTIVE BUNA-N
(Two Red Dots)
TWS= FULL STROKE-PTFE

VALVE BALL

BN = BUNA-N (Red Dot)
EP = EPDM (Blue Dot)
FS = SANIFLEX™
[Hytrel® (Cream)]
FV = SANITARY VITON®
(Two White Dots)
NE = NEOPRENE (Green Dot)
PU = POLYURETHANE (Brown)
TF = PTFE (White)
VT = VITON® (White Dot)

WF = WIL-FLEX™ [Santoprene®
(Orange Dot)]

VALVE SEAT

A = ALUMINUM
H = ALLOY C
S = STAINLESS STEEL

VALVE SEAT O-RING

BN = BUNA-N
EP = EPDM
FS = SANIFLEX™
[Hytrel® (Cream)]
PU = POLYURETHANE (Brown)
TF = PTFE (White)
WF = WIL-FLEX™
[Santoprene®]

SPECIALTY CODES

0014 BSPT Threaded
0023 Wing nuts
0070 Saniflo™ FDA
0079 Tri-clamp fittings, wing nuts
0080 Tri-clamp fittings ONLY
0100 Wil-Gard II™ 110V
0102 Wil-Gard II™ sensor wires ONLY

0103 Wil-Gard II™ 220V
0104 Wil-Gard II™ 110V, spark free
0206 PFA coated hardware,
Wil-Gard II™ sensor wires ONLY
0247 Discharge and inlet facing exhaust
0250 Discharge facing forward
0502 PFA coated hardware

0603 PFA coated hardware,
Wil-Gard II™ 110V
0608 PFA coated hardware,
Wil-Gard II™ 220V
0720 Hybrid bolted
0721 Hybrid bolted, BSPT
0722 Hybrid bolted, Saniflo™

NOTE: MOST ELASTOMERIC MATERIALS USE COLORED DOTS FOR IDENTIFICATION.

Viton® is a registered trademark of DuPont Dow Elastomers.

HOW IT WORKS — PUMP

The Wilden diaphragm pump is an air-operated, positive displacement, self-priming pump. These drawings show the flow pattern through the pump upon its initial stroke. It is assumed the pump has no fluid in it prior to its initial stroke.

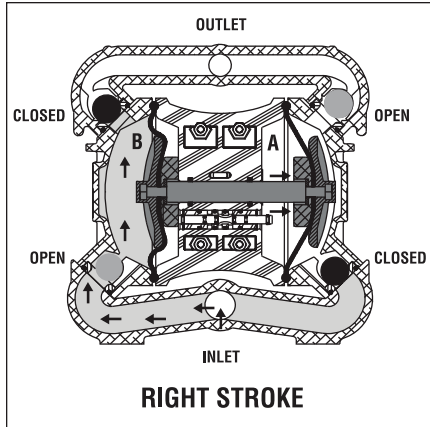

FIGURE 1 The air valve directs pressurized air to the back side of diaphragm A. The compressed air is applied directly to the liquid column separated by elastomeric diaphragms. The diaphragm acts as a separation membrane between the compressed air and liquid, balancing the load and removing mechanical stress from the diaphragm. The compressed air moves the diaphragm away from the center section of the pump. The opposite diaphragm is pulled in by the shaft connected to the pressurized diaphragm. Diaphragm B is on its suction stroke; air behind the diaphragm has been forced out to the atmosphere through the exhaust port of the pump. The movement of diaphragm B toward the center section of the pump creates a vacuum within chamber B. Atmospheric pressure forces fluid into the inlet manifold forcing the inlet valve ball off its seat. Liquid is free to move past the inlet valve ball and fill the liquid chamber (see shaded area).

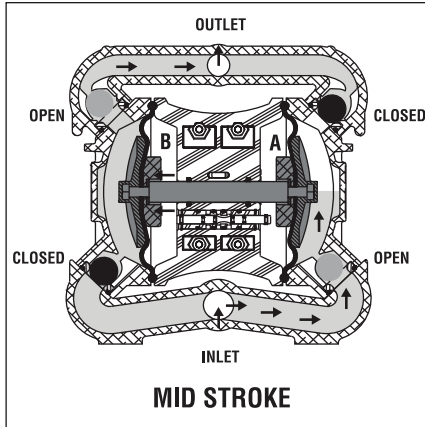

FIGURE 2 When the pressurized diaphragm, diaphragm A, reaches the limit of its discharge stroke, the air valve redirects pressurized air to the back side of diaphragm B. The pressurized air forces diaphragm B away from the center section while pulling diaphragm A to the center section. Diaphragm B is now on its discharge stroke. Diaphragm B forces the inlet valve ball onto its seat due to the hydraulic forces developed in the liquid chamber and manifold of the pump. These same hydraulic forces lift the discharge valve ball off its seat, while the opposite discharge valve ball is forced onto its seat, forcing fluid to flow through the pump discharge. The movement of diaphragm A toward the center section of the pump creates a vacuum within liquid chamber A. Atmospheric pressure forces fluid into the inlet manifold of the pump. The inlet valve ball is forced off its seat allowing the fluid being pumped to fill the liquid chamber.

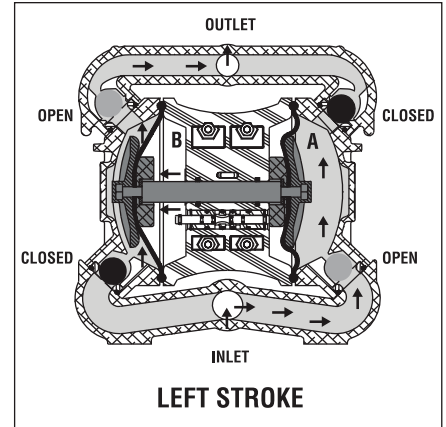
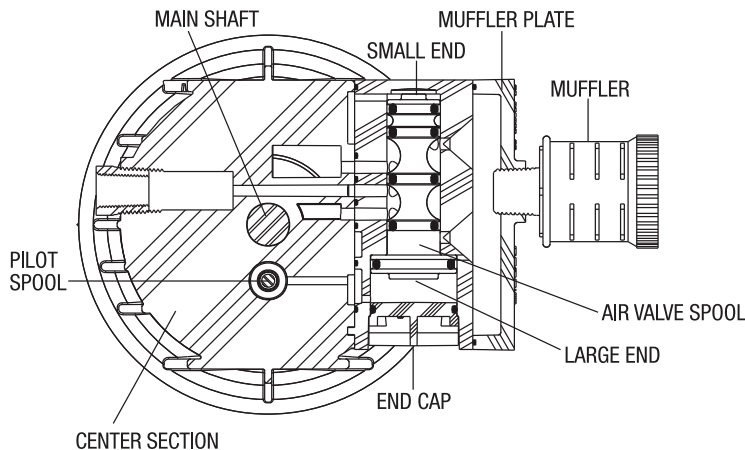

FIGURE 3 At completion of the stroke, the air valve again redirects air to the back side of diaphragm A, which starts diaphragm B on its exhaust stroke. As the pump reaches its original starting point, each diaphragm has gone through one exhaust and one discharge stroke. This constitutes one complete pumping cycle. The pump may take several cycles to completely prime depending on the conditions of the application.

HOW IT WORKS — AIR DISTRIBUTION SYSTEM



The Pro-Flo® patented air distribution system incorporates three moving parts: the air valve spool, the pilot spool, and the main shaft/diaphragm assembly. The heart of the system is the air valve spool and air valve. The air valve design incorporates an unbalanced spool. The smaller end of the spool is pressurized continuously, while the large end is alternately pressurized then exhausted to move the spool. The spool directs pressurized air to one air chamber while exhausting the other. The air causes the main shaft/diaphragm assembly to shift to one side — discharging liquid on that side and pulling liquid in on the other side. When the shaft reaches the end of its stroke, the inner piston actuates the pilot spool, which pressurizes and exhausts the large end of the air valve spool. The repositioning of the air valve spool routes the air to the other air chamber.

P2 Metal

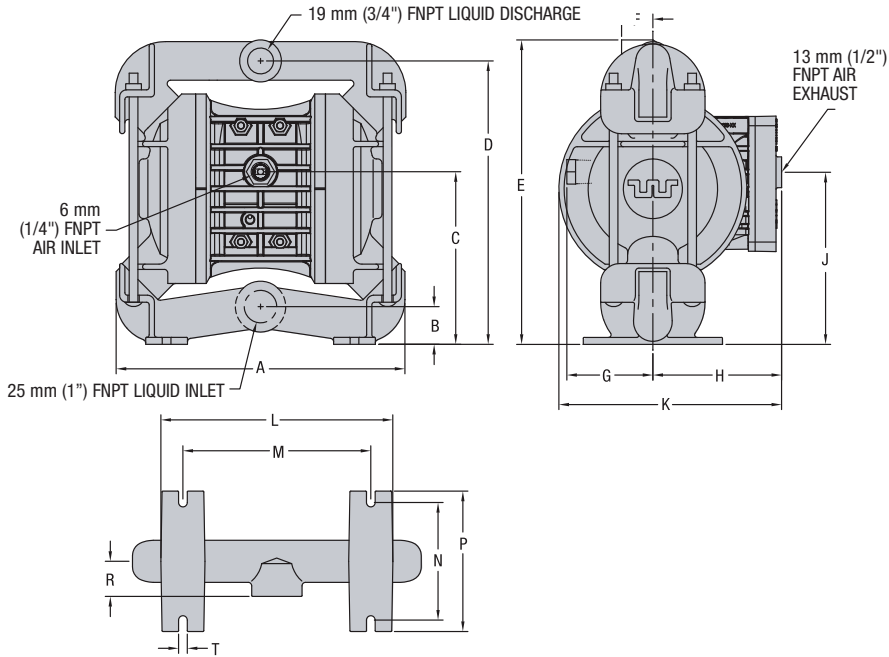

DIMENSIONS

ITEM	METRIC (mm)	STANDARD (inch)
A	267	10.5
B	36	1.4
C	152	6.0
D	254	10.0
E	279	11.0
F	28	1.1
G	76	3.0
H	117	4.6
J	152	6.0
K	201	7.9
L	211	8.3
M	173	6.8
N	107	4.2
P	127	5.0
R	33	1.3
S	8	0.3

P2 Metal Saniflo^{FDA}

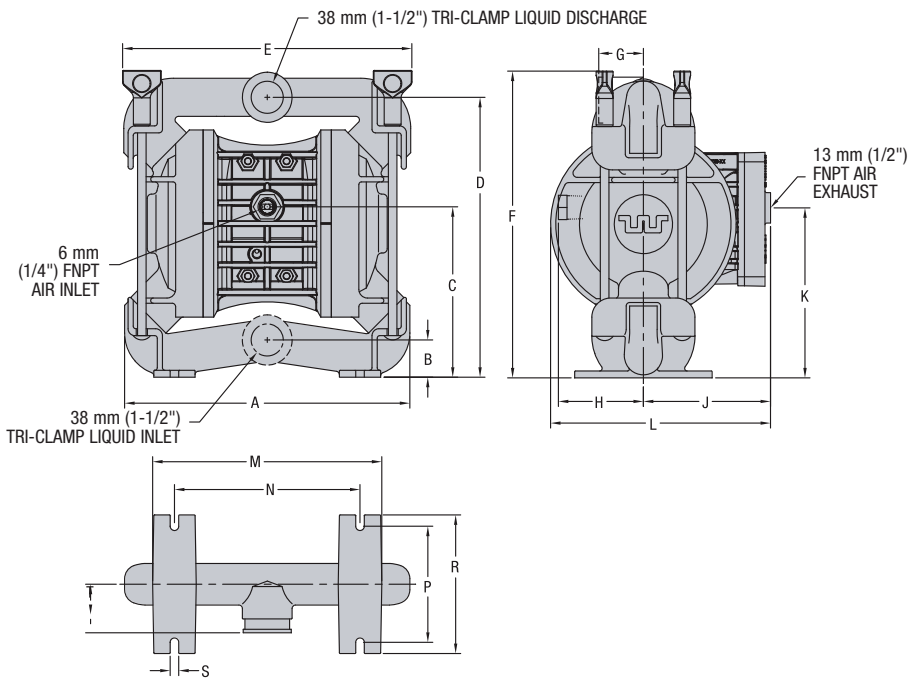

DIMENSIONS

ITEM	METRIC (mm)	STANDARD (inch)
A	264	10.4
B	36	1.4
C	157	6.2
D	257	10.1
E	254	10.0
F	282	11.1
G	41	1.6
H	76	3.0
J	117	4.6
K	155	6.1
L	203	8.0
M	211	8.3
N	173	6.8
P	107	4.2
R	127	5.0
S	8	0.3
T	43	1.7

P2 Metal Bolted

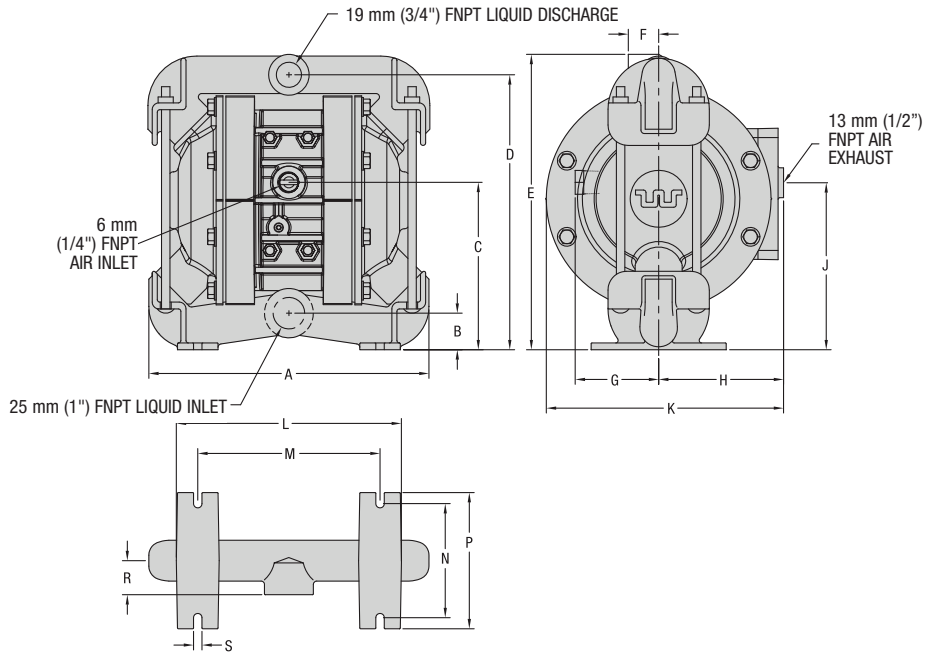

DIMENSIONS

ITEM	METRIC (mm)	STANDARD (inch)
A	267	10.5
B	36	1.4
C	152	6.0
D	254	10.0
E	279	11.0
F	28	1.1
G	76	3.0
H	117	4.6
J	152	6.0
K	229	9.0
L	211	8.3
M	173	6.8
N	107	4.2
P	127	5.0
R	33	1.3
S	8	0.3

PX2 Metal Bolted

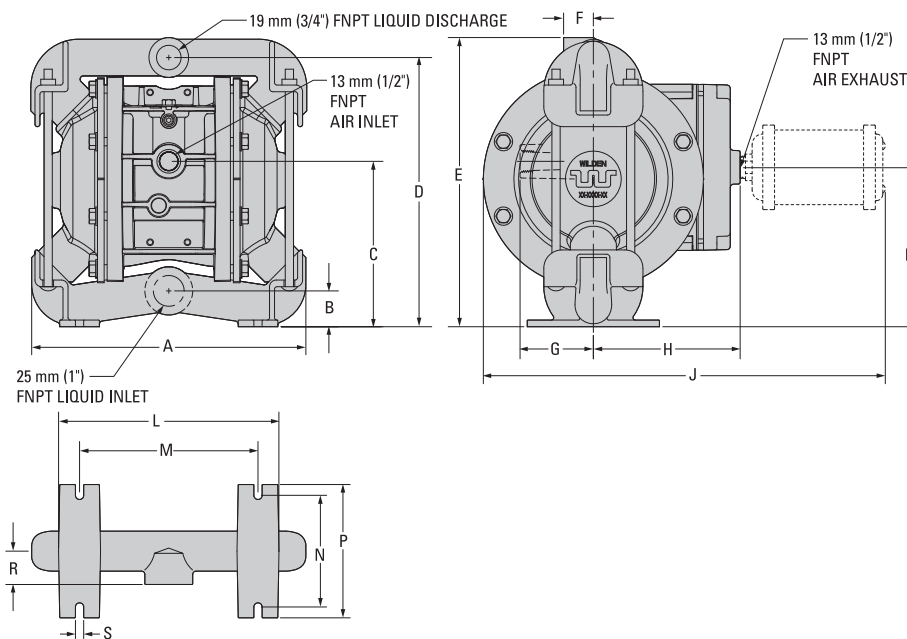

DIMENSIONS

ITEM	METRIC (mm)	STANDARD (inch)
A	267	10.5
B	36	1.4
C	157	6.2
D	254	10.0
E	279	11.0
F	28	1.1
G	71	2.8
H	140	5.5
J	384	15.1
K	152	6.0
L	211	8.3
M	173	6.8
N	107	4.2
P	127	5.0
R	33	1.3
S	8	0.3

**P2 METAL
PTFE-FITTED**

Height.....279 mm (11.0")
 Width.....267 mm (10.5")
 Depth201 mm (7.9")
 Est. Ship Weight.....Aluminum, 12 kg (26 lbs)
 Stainless Steel, 16 kg (36 lbs)
 Alloy C, 18 kg (40 lbs)
 Air Inlet.....6 mm (1/4")
 Inlet.....25 mm (1")
 Outlet19 mm (3/4")
 Suction Lift 3.04 m (10' Dry)
 8.53 m (28' Wet)
 Displacement per
 Stroke0.23 l (0.061 gal.)¹
 Max. Flow Rate.....163 lpm (43 gpm)
 Max. Size Solids3.2 mm (1/8")

¹Displacement per stroke was calculated at 4.8 bar (70 psig) air inlet pressure against a 2 bar (30 psig) head pressure.

Example: To pump 87 lpm (23 gpm) against a discharge pressure head of 2.7 bar (40 psig) requires 5.5 bar (80 psig) and 55.8 Nm³/h (33 scfm) air consumption. (See dot on chart.)

Caution: Do not exceed 8.6 bar (125 psig) air supply pressure.

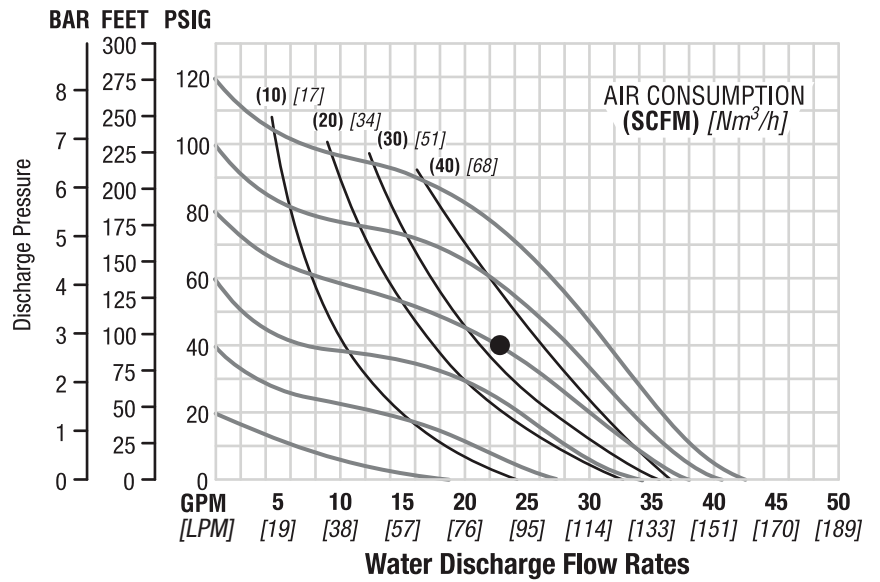

Flow rates indicated on chart were determined by pumping water.

For optimum life and performance, pumps should be specified so that daily operation parameters will fall in the center of the pump performance curve.

Section 5B SUCTION LIFT CURVE

P2 METAL SUCTION LIFT CAPABILITY

Suction lift curves are calibrated for pumps operating at 305 m (1,000') above sea level. This chart is meant to be a guide only. There are many variables which can affect your pump's operating characteristics. The number of intake and discharge elbows, viscosity of pumping fluid, elevation (atmospheric pressure) and pipe friction loss all affect the amount of suction lift your pump will attain.

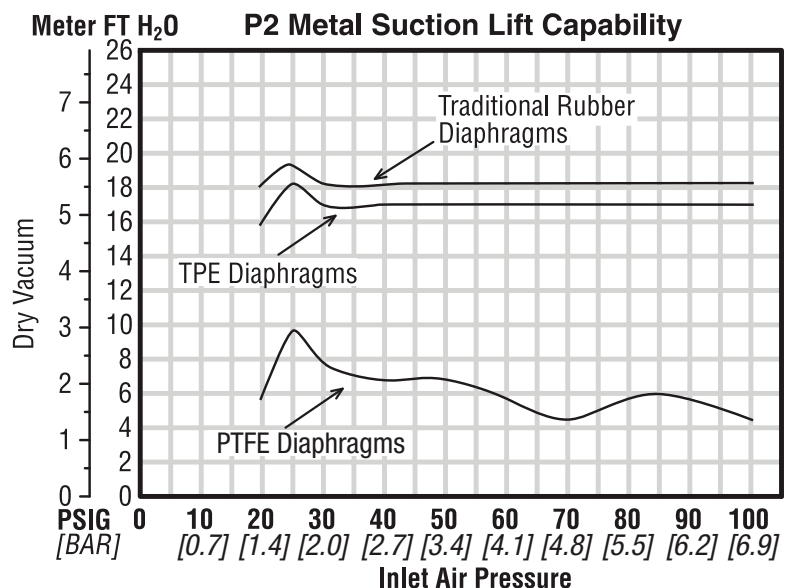

The P2 Pro-Flo® model has a 25 mm (1") inlet and 19 mm (3/4") outlet and is designed for flows to 170 lpm (45 gpm). Refer to Section 5 for performance characteristics. The P2 Metal pump is manufactured with wetted parts of Aluminum, 316 Stainless Steel, and Alloy C. The P2 is available with a polypropylene or acetal air valve and center section. A variety of diaphragms, valve balls, valve seats and o-rings are available to satisfy temperature, chemical compatibility, abrasion and flex concerns.

The suction pipe size should be at least 25 mm (1") diameter or larger if highly viscous material is being pumped. The suction hose must be non-collapsible, reinforced type as the P2 is capable of pulling a high vacuum. Discharge piping should be at least 25 mm (1"); larger diameter can be used to reduce friction losses. It is critical that all fittings and connections are airtight or a reduction or loss of pump suction capability will result.

INSTALLATION: Months of careful planning, study, and selection efforts can result in unsatisfactory pump performance if installation details are left to chance.

Premature failure and long term dissatisfaction can be avoided if reasonable care is exercised throughout the installation process.

LOCATION: Noise, safety, and other logistical factors usually dictate where equipment will be situated on the production floor. Multiple installations with conflicting requirements can result in congestion of utility areas, leaving few choices for additional pumps.

Within the framework of these and other existing conditions, every pump should be located in such a way that five key factors are balanced against each other to maximum advantage.

ACCESS: First of all, the location should be accessible. If it's easy to reach the pump, maintenance personnel will have an easier time carrying out routine inspections and adjustments. Should major repairs become necessary, ease of access can play a key role in speeding the repair process and reducing total downtime.

AIR SUPPLY: Every pump location should have an air line large enough to supply the volume of air necessary to achieve the desired pumping rate (see Section 5). Use air pressure up to a maximum of 8.6 bar (125 psig) depending on pumping requirements.

For best results, the pumps should use a 5 micron air filter, needle valve and regulator. The use of an air filter before the pump will ensure that the majority of any pipeline contaminants will be eliminated.

When operation is controlled by a solenoid valve in the air line, three-way valves should be used. This valve allows trapped air between the valve and the pump to bleed off which improves pump performance. Pumping volume can be determined by counting the number of strokes per minute and then multiplying the figure by the displacement per stroke.

MUFFLER: Sound levels are reduced below OSHA specifications using the standard Wilden muffler. Other mufflers can be used to further reduce sound levels, but they usually reduce pump performance.

ELEVATION: Selecting a site that is well within the pump's dynamic lift capability will assure that loss-of-prime troubles will be eliminated. In addition, pump efficiency can be adversely affected if proper attention is not given to site location.

PIPING: Final determination of the pump site should not be made until the piping problems of each possible location have been evaluated. The impact of current and future installations should be considered ahead of time to make sure that inadvertent restrictions are not created for any remaining sites.

The best choice possible will be a site involving the shortest and straightest hook-up of suction and discharge piping. Unnecessary elbows, bends, and fittings should be avoided. Pipe sizes should be selected so as to keep friction losses within practical limits. All piping should be supported independently of the pump. In addition, the piping should be aligned so as to avoid placing stress on the pump fittings.

Flexible hose can be installed to aid in absorbing the forces created by the natural reciprocating action of the pump. If the pump is to be bolted down to a solid location, a mounting pad placed between the pump and the foundation will assist in minimizing pump vibration. Flexible connections between the pump and rigid piping will also assist in minimizing pump vibration. If quick-closing valves are installed at any point in the discharge system, or if pulsation within a system becomes a problem, a surge suppressor should be installed to protect the pump, piping and gauges from surges and water hammer.

If the pump is to be used in a self-priming application, be sure that all connections are airtight and that the suction lift is within the model's ability. Note: Materials of construction and elastomer material have an effect on suction lift parameters. Please refer to Section 6 for specifics.

The P2 can be installed in submersible applications only when both the wetted and non-wetted portions are compatible with the material being pumped. If the pump is to be used in a submersible application, a hose should be attached to the pump's air and pilot spool exhaust ports and piped above the liquid level. The exhaust area for the pilot spool is designed to be tapped for a 3.2 mm (1/8") NPT fitting.

When pumps are installed in applications involving flooded suction or suction head pressures, a gate valve should be installed in the suction line to permit closing of the line for pump service.

Pumps in service with a positive suction head are most efficient when inlet pressure is limited to 0.5–0.7 bar (7–10 psig). Premature diaphragm failure may occur if positive suction is 0.7 bar (10 psig) and higher.

THE MODEL P2 WILL PASS 3.2 MM (1/8") SOLIDS. WHENEVER THE POSSIBILITY EXISTS THAT LARGER SOLID OBJECTS MAY BE SUCKED INTO THE PUMP, A STRAINER SHOULD BE USED ON THE SUCTION LINE.

CAUTION: DO NOT EXCEED 8.6 BAR (125 PSIG) AIR SUPPLY PRESSURE.

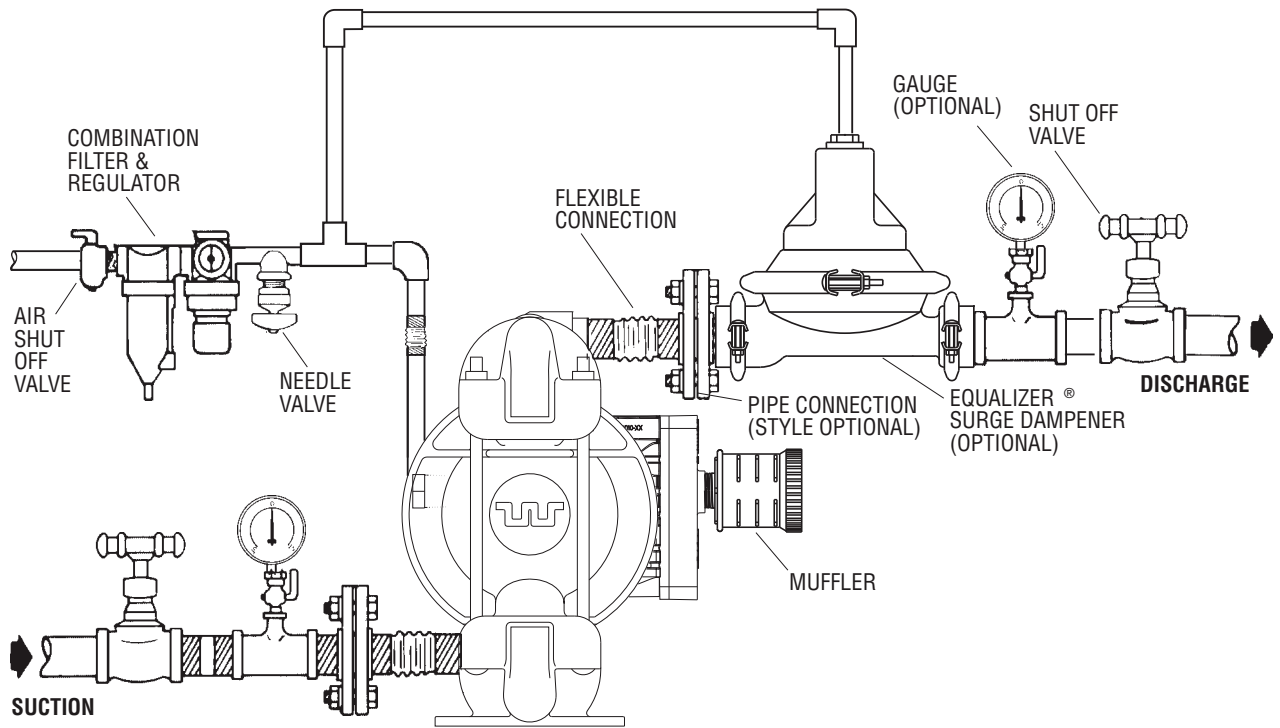

To stop the pump from operating in an emergency situation, simply close the shut-off valve (user supplied) installed in the air supply line. A properly functioning valve will stop the air supply to the pump, therefore stopping output. This shut-off valve should be located far enough away from the pumping equipment such that it can be reached safely in an emergency situation.

NOTE: In the event of a power failure, the shutoff valve should be closed, if the restarting of the pump is not desirable once power is regained.

SUGGESTED OPERATION & MAINTENANCE

OPERATION: Pump discharge rate can be controlled by limiting the volume and/or pressure of the air supply to the pump (preferred method). An air regulator is used to regulate air pressure. A needle valve is used to regulate volume. Pump discharge rate can also be controlled by throttling the pump discharge by partially closing a valve in the discharge line of the pump. This action increases friction loss which reduces flow rate. This is useful when the need exists to control the pump from a remote location. When the pump discharge pressure equals or exceeds the air supply pressure, the pump will stop; no bypass or pressure relief valve is needed, and pump damage will not occur. The pump has reached a “deadhead” situation and can be restarted by reducing the fluid discharge pressure or increasing the air inlet pressure. The Wilden P2 pump runs solely on compressed air and does not generate heat, therefore your process fluid temperature will not be affected.

RECORDS: When service is required, a record should be made of all necessary repairs and replacements. Over a period of time, such records can become a valuable tool for predicting and preventing future maintenance problems and unscheduled downtime. In addition, accurate records make it possible to identify pumps that are poorly suited to their applications.

MAINTENANCE AND INSPECTIONS: Since each application is unique, maintenance schedules may be different for every pump. Frequency of use, line pressure, viscosity and abrasiveness of process fluid all affect the parts life of a Wilden pump. Periodic inspections have been found to offer the best means for preventing unscheduled pump downtime. Personnel familiar with the pump’s construction and service should be informed of any abnormalities that are detected during operation.

TROUBLESHOOTING

Pump will not run or runs slowly.

1. Ensure that the air inlet pressure is at least 0.4 bar (5 psig) above startup pressure and that the differential pressure (the difference between air inlet and liquid discharge pressures) is not less than 0.7 bar (10 psig).
2. Check air inlet filter for debris (see recommended installation).
3. Check for extreme air leakage (blow by) which would indicate worn seals/bores in the air valve, pilot spool, main shaft.
4. Disassemble pump and check for obstructions in the air passageways or objects which would obstruct the movement of internal parts.
5. Check for sticking ball check valves. If material being pumped is not compatible with pump elastomers, swelling may occur. Replace ball check valves and seals with proper elastomers. Also, as the check valve balls wear out, they become smaller and can become stuck in the seats. In this case, replace balls and seats.
6. Check for broken inner piston which will cause the air valve spool to be unable to shift.
7. Remove plug from pilot spool exhaust.

Pump runs but little or no product flows.

1. Check for pump cavitation; slow pump speed down to allow thick material to flow into liquid chambers.
2. Verify that vacuum required to lift liquid is not greater than the vapor pressure of the material being pumped (cavitation).

3. Check for sticking ball check valves. If material being pumped is not compatible with pump elastomers, swelling may occur. Replace ball check valves and seals with proper elastomers. Also, as the check valve balls wear out, they become smaller and can become stuck in the seats. In this case, replace balls and seats.

Pump air valve freezes.

1. Check for excessive moisture in compressed air. Either install a dryer or hot air generator for compressed air. Alternatively, a coalescing filter may be used to remove the water from the compressed air in some applications.

Air bubbles in pump discharge.

1. Check for ruptured diaphragm.
2. Check tightness of outer pistons (refer to Section 8C).
3. Check tightness of clamp bands and integrity of o-rings and seals, especially at intake manifold.
4. Ensure pipe connections are airtight.

Product comes out air exhaust.

1. Check for diaphragm rupture.
2. Check tightness of outer pistons to shaft.

PUMP DISASSEMBLY

CAUTION: Before any maintenance or repair is attempted, the compressed air line to the pump should be disconnected and all air pressure allowed to bleed from the pump. Disconnect all intake, discharge, and air lines. Drain the pump by turning it upside down and allowing any fluid to flow into a suitable container. Be aware of any hazardous effects of contact with your process fluid.

The Wilden model P2 has a 25 mm (1") inlet and 19 mm (3/4") outlet and is designed for flows up to 170 lpm (45 gpm). The single-piece center section, consisting of center block and air chambers, is molded of acetal or Polypropylene. All o-rings used in the pump are of a special material and shore hardness that should only be replaced with factory-supplied parts.

TOOLS REQUIRED:

Adjustable Wrench
1/2" Box End Wrench
9/16" Box End Wrench
3/4" Box End Wrench
1/4" Hex Head Wrench
Vise equipped with soft jaws (such as plywood, plastic or other suitable material)

NOTE: The model used for these instructions incorporates rubber diaphragms, balls, and seats. Models with PTFE diaphragms, balls and seats are the same except where noted.

**DISASSEMBLY:**

Figure 1

Step 1.

Before starting disassembly, mark a line from each liquid chamber to its corresponding air chamber. This line will assist in proper alignment during reassembly.

**Step 2.**

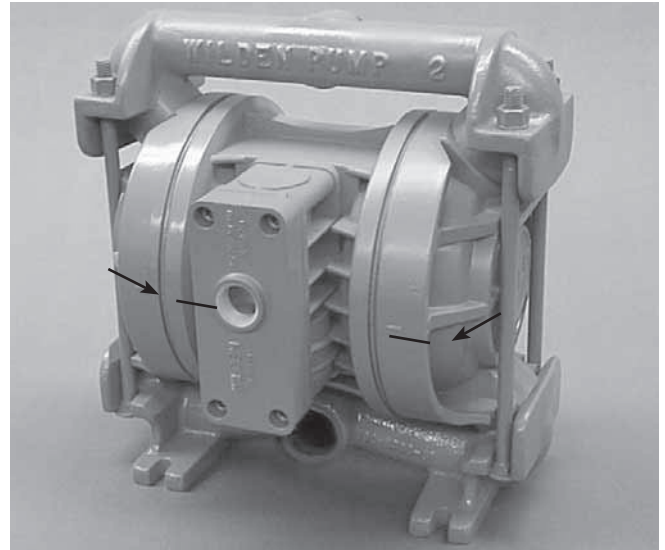
Figure 2

Utilizing the 9/16" box wrench, start by removing the four long carriage bolts that secure the top and bottom manifolds to the center section.

**Step 3.**

Figure 3

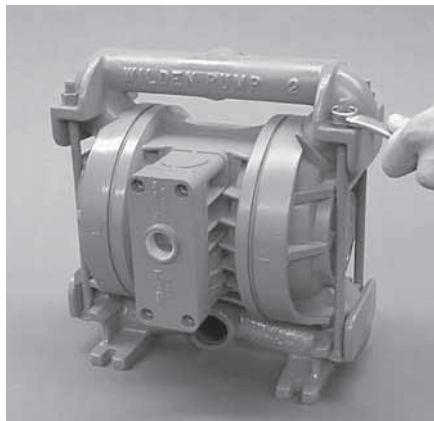
Remove the top manifold and lift the center section off the inlet manifold.

**Step 4.**

Figure 4

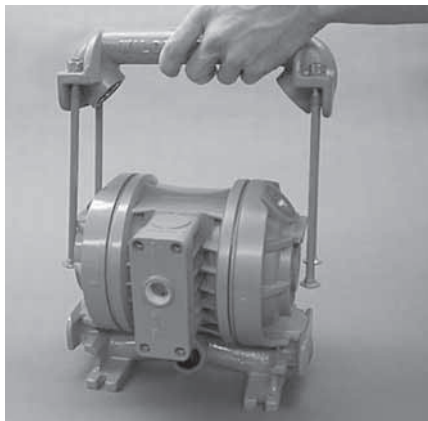
Remove the discharge valve balls, seats and o-rings from the discharge manifold and inspect for nicks, gouges, chemical attack or abrasive wear. Replace worn parts with genuine Wilden parts for reliable performance. PTFE o-rings should be replaced when reassembled.

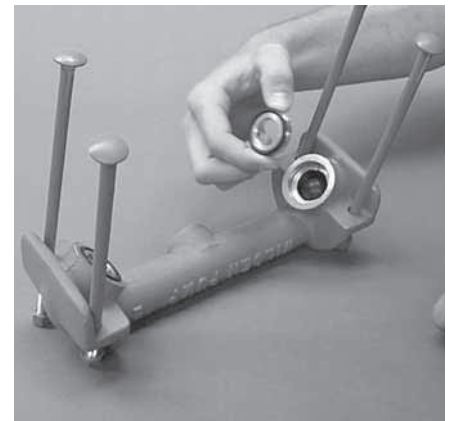

Step 5. *Figure 5*

With one 1/2" box wrench (stainless steel or Alloy C configuration) or 1/4" hex head wrench (aluminum configuration), remove the liquid chamber from the center section. **BOLTED CONFIGURATION ONLY.** Stainless steel configuration shown above.

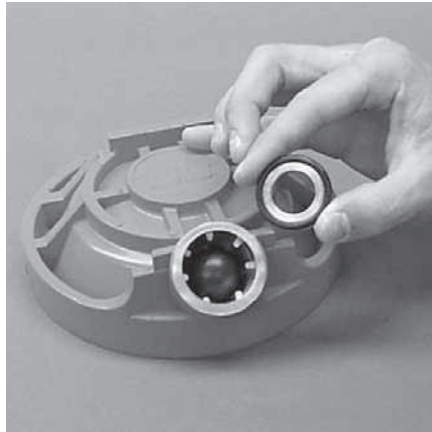

Step 6. *Figure 6*

Inspect the valve seat, valve seat o-ring, and valve ball from intake manifold. Check for nicks, gouges, chemical attack or abrasive wear. Replace worn parts with genuine Wilden parts for reliable performance. PTFE o-rings should be replaced when reassembled.

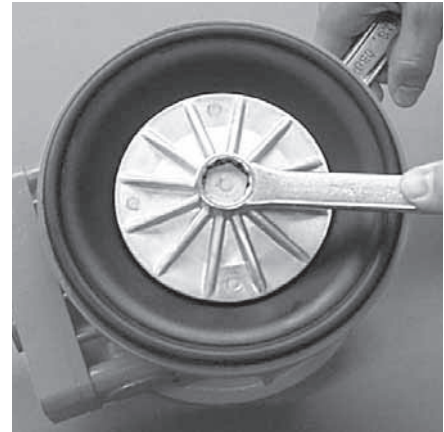

Step 7. *Figure 7*

With the 3/4" box wrench or by rotating the diaphragm by hand, remove the diaphragm assembly.



Step 8. *Figure 8*

NOTE: Due to varying torque values, one of the following two situations may occur:
1) The outer piston, diaphragm and inner piston remain attached to the shaft and the entire assembly can be removed from the center section.



Step 9. *Figure 9*

2) The outer piston, diaphragm, inner piston, and disc spring separate from the shaft which remains connected to the opposite side diaphragm assembly. PTFE-fitted pumps come standard with back-up diaphragms (not shown).

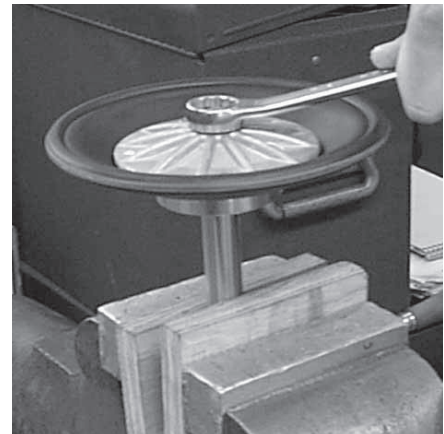

Step 10. *Figure 10*

To remove the diaphragm assembly from the shaft, secure shaft with soft jaws (a vise fitted with plywood or other suitable material) to ensure shaft is not nicked, scratched, or gouged. Using a wrench, remove diaphragm assembly from shaft. Inspect all parts for wear and replace with genuine Wilden parts if necessary.

AIR VALVE/CENTER SECTION DISASSEMBLY

AIR VALVE DISASSEMBLY:

CAUTION: Before any maintenance or repair is attempted, the compressed air line to the pump should be disconnected and all air pressure allowed to bleed from the pump. Disconnect all intake, discharge, and air lines. Drain the pump by turning it upside down and allowing any fluid to flow into a suitable container. Be aware of hazardous effects of contact with your process fluid.

The Wilden Metal P2 utilizes a revolutionary Pro-Flo[®] air distribution system. A 6 mm (1/4") air inlet connects the air supply to the center section. Proprietary composite seals reduce the coefficient of friction and allow the P2 to run lube-free. Constructed of acetal or polypropylene air valve with a polypropylene center section, the Pro-Flo[®] air distribution system is designed to perform in on/off, non-freezing, non-stalling, tough duty applications.

TOOLS REQUIRED:

3/16" Hex Head Wrench
Snap Ring Pliers
O-Ring Pick

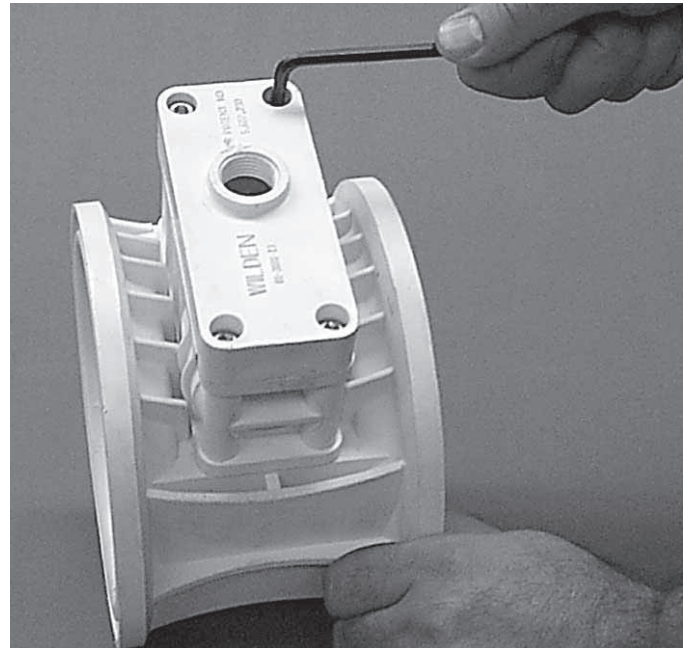

Step 1.

Figure 1

Loosen the air valve bolts utilizing a 3/16" hex head wrench.

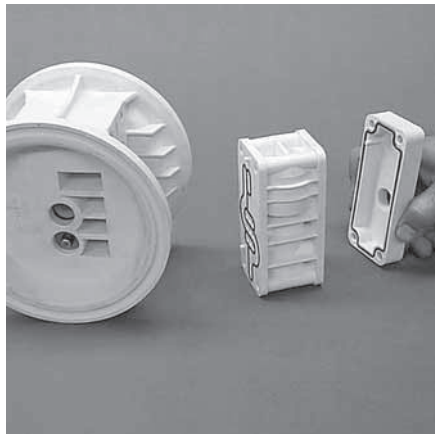

Step 2.

Figure 2

Remove muffer plate and air valve bolts from air valve assembly exposing muffer gasket for inspection. Replace if necessary.



Step 3.

Figure 3

Lift away air valve assembly and remove air valve gasket for inspection. Replace if necessary.



Step 4.

Figure 4

Remove air valve end cap to expose air valve spool by simply lifting up on end cap once air valve bolts are removed.



Step 5. *Figure 5*

Remove air valve spool from air valve body by threading one air valve bolt into the end of the spool and gently sliding the spool out of the air valve body. Inspect seals for signs of wear and replace entire assembly if necessary. Use caution when handling air valve spool to prevent damaging seals.

NOTE: Seals should not be removed from assembly.
Seals are not sold separately.

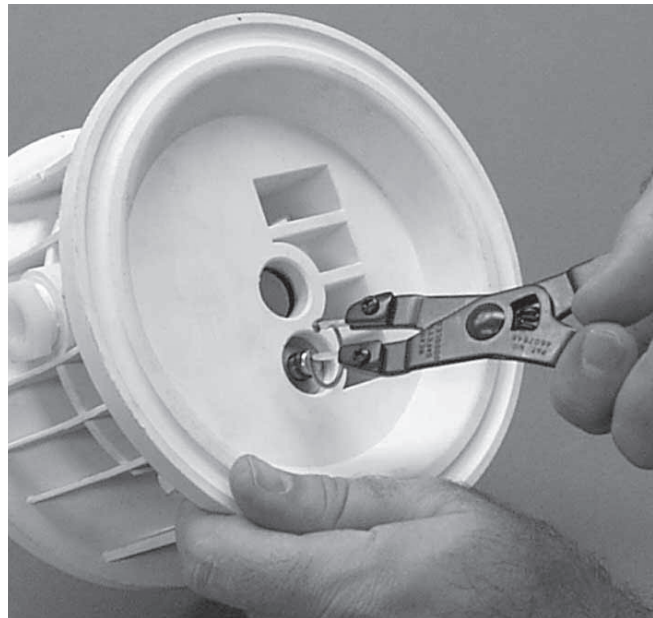

Step 6. *Figure 6*

Remove pilot spool sleeve retaining snap ring on both sides of center section with snap ring pliers.



Step 7. *Figure 7*

Remove pilot spool sleeve from center section.

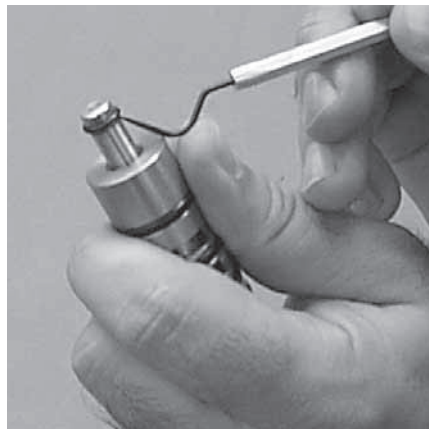

Step 8. *Figure 8*

With o-ring pick, gently remove pilot spool retaining o-ring from the end of the pilot spool opposite the marked end. Replace if necessary. Gently remove pilot spool from sleeve and inspect spool and seals for nicks, gouges or other signs of wear. Replace pilot sleeve assembly or outer sleeve o-rings if necessary.

NOTE: Seals should not be removed from pilot spool.
Seals are not sold separately.

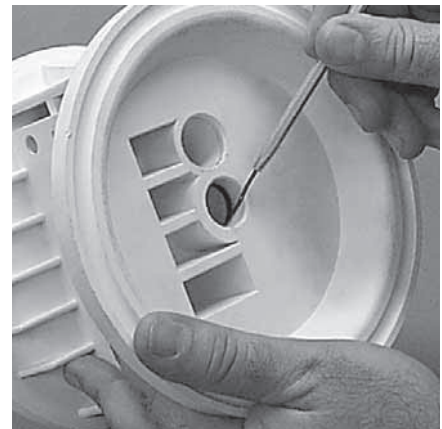

Step 9. *Figure 9*

Check center section Glyd™ rings for signs of wear. If necessary, remove Glyd™ rings with o-ring pick and replace.

ASSEMBLY:

Upon performing applicable maintenance to the air distribution system, the pump can now be reassembled. Please refer to the disassembly instructions for photos and parts placement. To reassemble the pump, follow the disassembly instructions in reverse order. The air distribution system needs to be assembled first, then the diaphragms and finally the wetted path. Please find the applicable torque specifications on this page. The following tips will assist in the assembly process.

- Clean the inside of the center section shaft bore to ensure no damage is done to new seals.
- Stainless bolts should be lubed to reduce the possibility of seizing during tightening.
- Be sure to tighten outer pistons simultaneously on PTFE-fitted pumps to ensure proper torque values.
- Place one liquid chamber on its side and align center section with chamber using alignment marks made during disassembly. Push down on diaphragm assembly until diaphragm is inverted. Place opposite liquid chamber on center section and align.

- Position valve balls, seats, and o-rings in discharge manifold. Place vertical bolt through discharge manifold with threads pointing up. Install washer and start threads of bolt (about 1-1/2 turns).
- Place center section and liquid chambers on intake manifold.
- Position discharge manifold and bolt assembly on liquid chambers. Ensure proper alignment of mating surfaces between liquid chambers and manifolds before tightening bolts.
- Apply a small amount of Loctite 242 to the shaft interval threads before the diaphragm assembly.
- Concave side of disc spring in diaphragm assembly faces **toward** inner piston.

PRO-FLO[®] MAXIMUM TORQUE SPECIFICATIONS

Description of Part	Metal Pumps
Air Valve, Pro-Flo [®]	3.1 N•m (27 in-lbs)
Air Inlet, Reducer Bushing	10.9 N•m (8 ft-lbs)
Outer Piston, Rubber and PTFE-Fitted	40.7 N•m (30 ft-lbs)
Vertical Bolts	31.1 N•m (23 ft-lbs)
Vertical Bolts, Bolted Metal Only	13.0 N•m (115 in-lbs)
*Liquid Chamber /Air Chamber	13.0 N•m (115 in-lbs)

*For bolted liquid chamber to bolted center section configuration only.

PRO-FLO X[™] MAXIMUM TORQUE SPECIFICATIONS

Description of Part	Metal Pumps
Air Valve	11.3 N•m (100 in-lbs)
Dial Set Screw	11.3 N•m (100 in-lbs)
Outer Piston	40.7 N•m (30 ft-lbs)
Vertical Bolts (Metal Only)	13.0 N•m (115 in-lbs)
*Liquid Chamber /Air Chamber	13.0 N•m (115 in-lbs)

*For bolted liquid chamber to bolted center section configuration only.



EXPLODED VIEW AND PARTS LISTING

PX2 METAL

Rubber/TPE-Fitted

EXPLODED VIEW

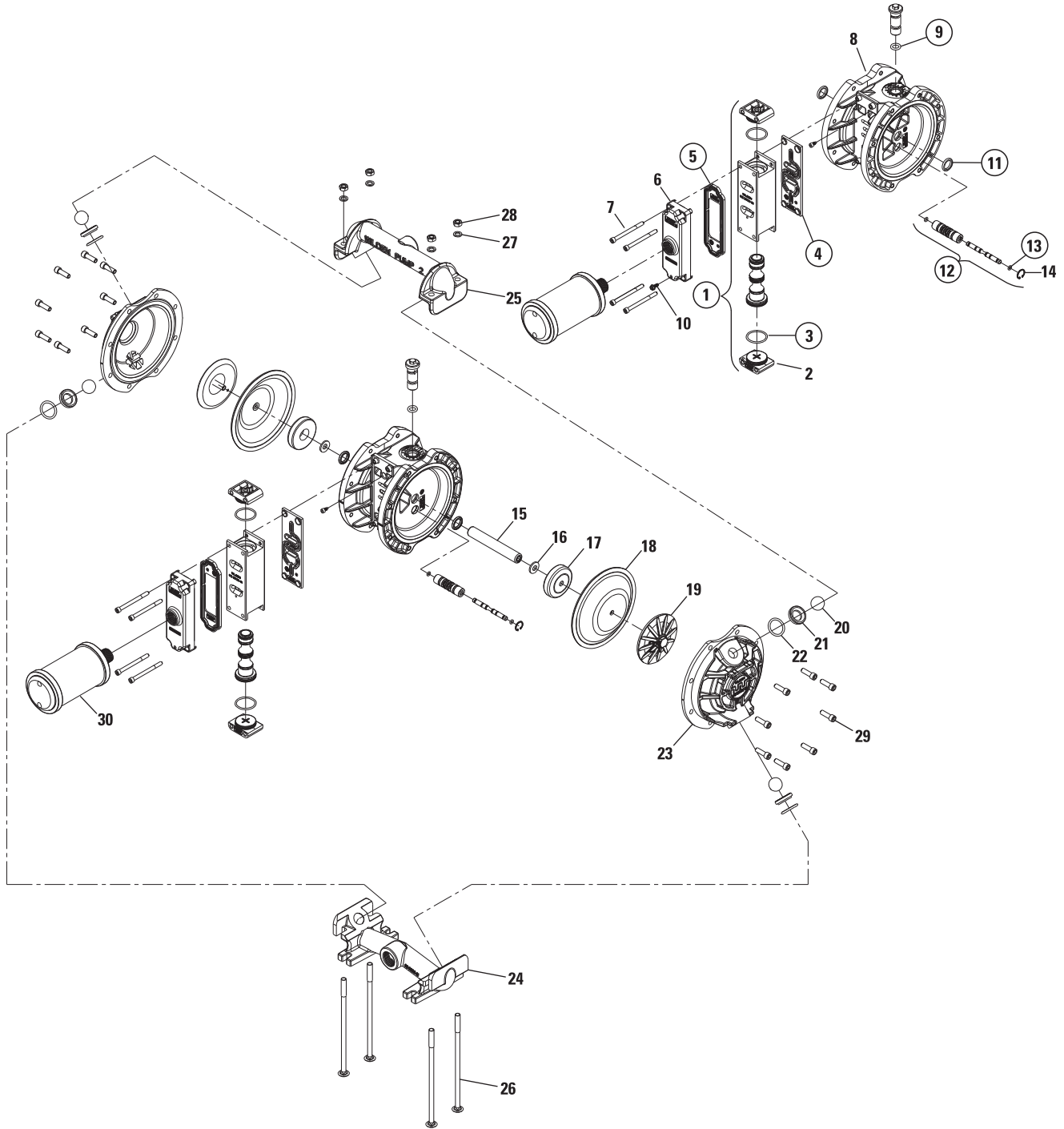

EXPLODED VIEW AND PARTS LISTING

PX2 METAL

Rubber/TPE-Fitted

PARTS LISTING

Item	Description	Qty	XPX2/AAAAA P/N	PX2/SSAAA P/N
1	Pro-Flo X® Air Valve Assembly¹	1	02-2030-01	02-2030-01
2	End Cap	2	01-2340-01	01-2340-01
3	O-Ring (-126), End Cap (Ø1.362 x Ø.103)	2	01-2395-52	01-2395-52
4	Gasket, Air Valve, Pro-Flo X®	1	02-2620-52	02-2620-52
5	Gasket, Muffler Plate, Pro-Flo X®	1	02-3502-52	02-3502-52
6	Muffler Plate, Pro-Flo X®	1	02-3185-01	02-3185-01
7	Screw, SHC, Air Valve (1/4"-20 x 3")	4	01-6001-03	01-6001-03
8	Center Section Assembly, Pro-Flo X® ²	1	02-3148-01	02-3148-01
9	O-Ring (-206), Air Adjustment Pin (Ø.484 x Ø.139)	1	00-1300-52	00-1300-52
10	Screw, 10-32 x .50 Self-Tapping Grounding	1	04-6345-08	04-6345-08
11	Shaft Seal	2	02-3210-55-225	02-3210-55-225
12	Pilot Sleeve Assembly	1	02-3880-99	02-3880-99
13	Pilot Spool Retaining O-Ring	1	04-2650-49-700	04-2650-49-700
14	Retaining Ring	1	00-2650-03	00-2650-03
15	Shaft, P2 Straight	1	02-3810-03	02-3810-03
16	Disc Spring	2	02-6802-08	02-6802-08
17	Inner Piston	2	02-3701-01	02-3701-01
18	Diaphragm	2	*	*
19	Outer Piston	2	02-4550-01	02-4550-03
20	Valve Ball	4	*	*
21	Valve Seat	4	02-1120-01	02-1120-03
22	Valve Seat O-ring	4	*	*
23	Liquid Chamber	2	02-5005-01	02-5005-03
24	Inlet Manifold NPT	1	02-5080-01	02-5080-03
	Inlet Manifold BSPT	1	02-5080-01-14	02-5080-03-14
25	Discharge Manifold NPT	1	02-5020-01	02-5020-03
	Discharge Manifold BSPT	1	02-5020-01-14	02-5020-03-14
26	Bolt, RHSN 3/8"-16 x 8 1/2"	4	02-6080-08	02-6080-03
27	Washer, Flat, (.390 I.D. x .625 O.D. x .063 THK)	4	15-6720-08	02-6730-03
28	Nut, Hex 3/8"-16	4	02-6430-08	02-6430-03
29	Screw, SHC, (5/16"-18 x 1")	16	95-6011-08	08-6180-03-42
30	Muffler	1	08-3510-99R	08-3510-99R
31	Stud, 3/8"-16 x 1 1/4" (Not Shown)	2	N/A	02-6150-08

* Refer to Elastomer Options in Section 9.

¹Air Valve Assembly includes item numbers 2 and 3.

²Center Section Assembly includes items 10, 11 and 12.

All boldface items are primary wear items

Specialty Codes

0720 Specialty Code = Hybrid

0721 Specialty Code = Hybrid BSPT

EXPLODED VIEW AND PARTS LISTING

PX2 METAL

PTFE-Fitted

EXPLODED VIEW

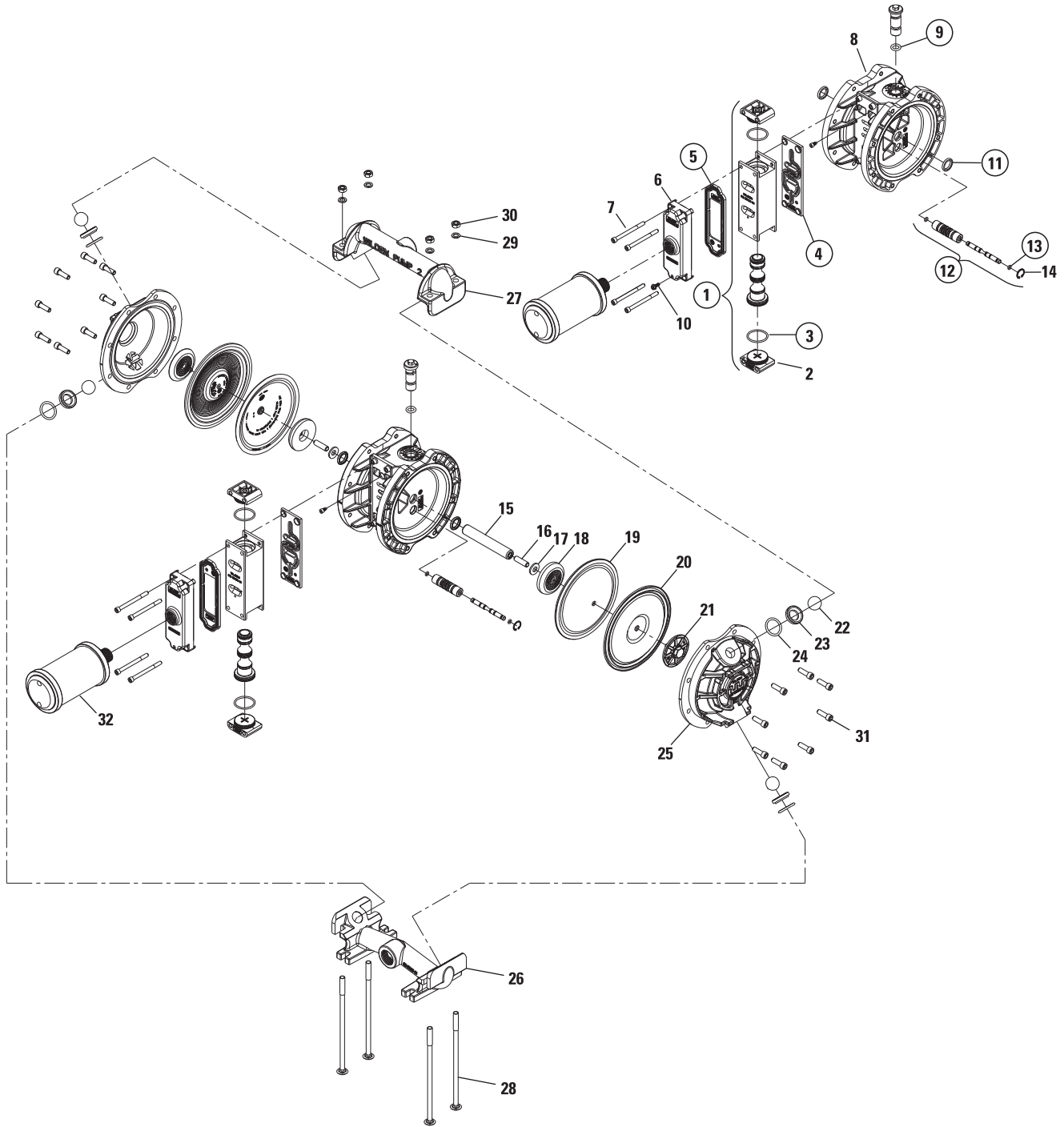

EXPLODED VIEW AND PARTS LISTING

PX2 METAL

PTFE-Fitted

PARTS LISTING

Item	Description	Qty	XPX2/AAAAA P/N	PX2/SSAAA P/N
1	Pro-Flo X® Air Valve Assembly¹	1	02-2030-01	02-2030-01
2	End Cap	2	01-2340-01	01-2340-01
3	O-Ring (-126), End Cap (Ø1.362 x Ø.103)	2	01-2395-52	01-2395-52
4	Gasket, Air Valve, Pro-Flo X®	1	02-2620-52	02-2620-52
5	Gasket, Muffler Plate, Pro-Flo X®	1	02-3502-52	02-3502-52
6	Muffler Plate, Pro-Flo X®	1	02-3185-01	02-3185-01
7	Screw, SHC, Air Valve (1/4" -20 x 3")	4	01-6001-03	01-6001-03
8	Center Section Assembly, Pro-Flo X® ²	1	02-3148-01	02-3148-01
9	O-Ring (-206), Air Adjustment Pin (Ø.484 x Ø.139)	1	00-1300-52	00-1300-52
10	Screw, 10-32 x .50 Self-Tapping Grounding	1	04-6345-08	04-6345-08
11	Shaft Seal	2	02-3210-55-225	02-3210-55-225
12	Pilot Sleeve Assembly	1	02-3880-99	02-3880-99
13	Pilot Spool Retaining O-Ring	1	04-2650-49-700	04-2650-49-700
14	Retaining Ring	1	00-2650-03	00-2650-03
15	Shaft, P2 PTFE Straight	1	02-3840-03	02-3840-03
16	Stud, 3/8-16 x 1 1/4"	2	02-6150-08	02-6150-08
17	Disc Spring	2	02-6802-08	02-6802-08
18	Inner Piston	2	02-3751-01	02-3751-01
19	Back-up Diaphragm	2	*	*
20	Diaphragm	2	02-1010-55	02-1010-55
21	Outer Piston	2	02-4601-01	02-4600-03
22	Valve Ball	4	02-1080-55	02-1080-55
23	Valve Seat	4	02-1120-01	02-1120-03
24	Valve Seat O-ring	4	02-1200-55	02-1200-55
25	Liquid Chamber	2	02-5005-01	02-5005-03
26	Inlet Manifold NPT	1	02-5080-01	02-5080-03
	Inlet Manifold BSPT	1	02-5080-01-14	02-5080-03-14
27	Discharge Manifold NPT	1	02-5020-01	02-5020-03
	Discharge Manifold BSPT	1	02-5020-01-14	02-5020-03-14
28	Bolt, RHSN 3/8" -16 x 8 1/2"	4	02-6080-08	02-6080-03
29	Washer, Flat, (.390 I.D. X .625 O.D. X .063 THK)	4	15-6720-08	15-6720-08
30	Nut, Hex 3/8" -16	4	02-6430-08	02-6430-03
31	Screw, SHC, (5/16" -18 x 1")	16	95-6011-08	08-6180-03-42
32	Muffler	1	08-3510-99R	08-3510-99R

*Refer to Elastomer Options in Section 9.

¹Air Valve Assembly includes item numbers 2 and 3.

²Center Section Assembly includes items 10, 11 and 12.

All boldface items are primary wear items

Specialty Codes

0720 Specialty Code = Hybrid

0721 Specialty Code = Hybrid BSPT

EXPLODED VIEW AND PARTS LISTING

P2 METAL

Rubber/TPE-Fitted

EXPLODED VIEW

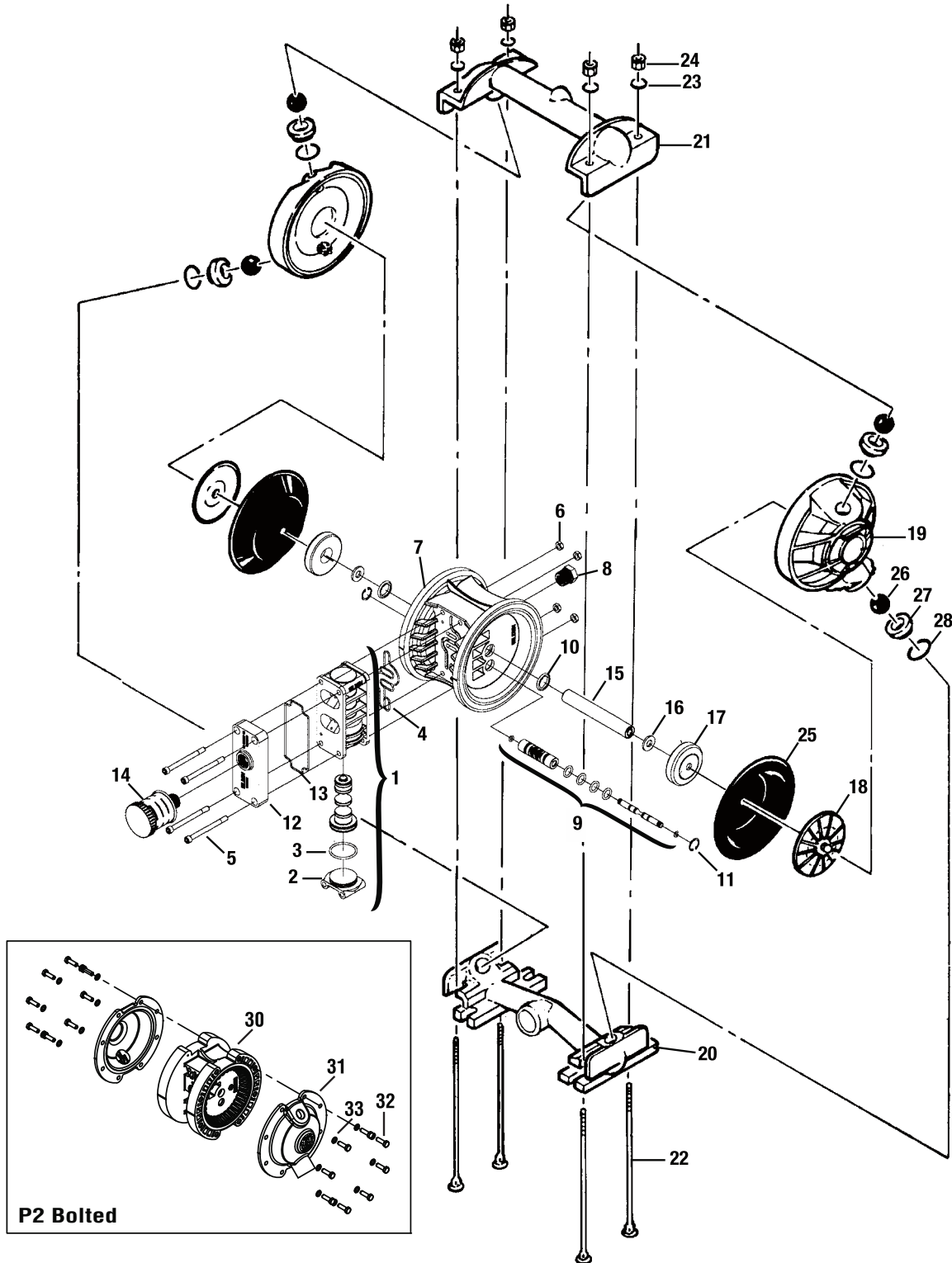

EXPLODED VIEW AND PARTS LISTING

P2 METAL

Rubber/TPE-Fitted

PARTS LISTING

Item	Part Description	Qty Per Pump	Polypropylene Center Section				Acetal Center Section			
			P2/AAPPP P/N	P2/SSPPP P/N	P2/HHPPP P/N	P2/SSPPP/0070 P/N	P2/AALLL P/N	P2/SSLLL P/N	P2/HHLLL P/N	P2/SSLLL/0070 P/N
1	Pro-Flo® Air Valve Assembly ¹	1	01-2010-20	01-2010-20	01-2010-20	01-2010-20	01-2010-13	01-2010-13	01-2010-13	01-2010-13
2	End Cap	1	01-2332-20	01-2332-20	01-2332-20	01-2332-20	01-2332-13	01-2332-13	01-2332-13	01-2332-13
3	O-Ring, End Cap	1	01-2395-52	01-2395-52	01-2395-52	01-2395-52	01-2395-52	01-2395-52	01-2395-52	01-2395-52
4	Gasket, Air Valve	1	01-2615-52	01-2615-52	01-2615-52	01-2615-52	01-2615-52	01-2615-52	01-2615-52	01-2615-52
5	Screw, HSHC, Air Valve 1/4"-20	4	01-6001-03	01-6001-03	01-6001-03	01-6001-03	01-6001-03	01-6001-03	01-6001-03	01-6001-03
6	Nut, Hex, 1/4"-20	4	04-6400-03	04-6400-03	04-6400-03	04-6400-03	04-6400-03	04-6400-03	04-6400-03	04-6400-03
7	Center Section	1	02-3145-20	02-3145-20	02-3145-20	02-3145-20	02-3145-13	02-3145-13	02-3145-13	02-3145-13
8	Bushing, Reducer	1	01-6950-20	01-6950-20	01-6950-20	01-6950-20	01-6950-13	01-6950-13	01-6950-13	01-6950-13
9	Removable Pilot Sleeve Assembly	1	02-3880-99	02-3880-99	02-3880-99	02-3880-99	02-3880-99	02-3880-99	02-3880-99	02-3880-99
10	Glyd™ Ring II	2	02-3210-55-225	02-3210-55-225	02-3210-55-225	02-3210-55-225	02-3210-55-225	02-3210-55-225	02-3210-55-225	02-3210-55-225
11	Retaining Ring	2	00-2650-03	00-2650-03	00-2650-03	00-2650-03	00-2650-03	00-2650-03	00-2650-03	00-2650-03
12	Muffler Plate	1	01-3181-20	01-3181-20	01-3181-20	01-3181-20	01-3181-13	01-3181-13	01-3181-13	01-3181-13
13	Gasket, Muffler Plate	1	01-3505-52	01-3505-52	01-3505-52	01-3505-52	01-3505-52	01-3505-52	01-3505-52	01-3505-52
14	Muffler	1	02-3510-99	02-3510-99	02-3510-99	02-3510-99	02-3510-99	02-3510-99	02-3510-99	02-3510-99
15	Shaft, Pro-Flo®	1	02-3810-03	02-3810-03	02-3810-03	02-3810-03	02-3810-03	02-3810-03	02-3810-03	02-3810-03
16	Disc Spring (Belleville Washer)	2	02-6802-08	02-6802-08	02-6802-08	02-6802-08	02-6802-08	02-6802-08	02-6802-08	02-6802-08
17	Inner Piston	2	02-3701-01	02-3701-01	02-3701-01	02-3701-01	02-3701-01	02-3701-01	02-3701-01	02-3701-01
18	Outer Piston	2	02-4550-01	02-4550-03	02-4550-04	02-4600-03	02-4550-01	02-4550-03	02-4550-04	02-4600-03
19	Liquid Chamber	2	02-5000-01	02-5000-03	02-5000-04	02-5000-03	02-5000-01	02-5000-03	02-5000-04	02-5000-03
20	Inlet Manifold	1	02-5080-01	02-5080-03	02-5080-04	02-5080-03-70	02-5080-01	02-5080-03	02-5080-04	02-5085-03-70
21	Discharge Manifold	1	02-5020-01	02-5020-03	02-5020-04	02-5020-03-70	02-5020-01	02-5020-03	02-5020-04	02-5025-03-70
22	Screw, SHCS (Chamber Bolt)	4	02-6080-08	02-6080-03	02-6080-03	02-6080-03	02-6080-08	02-6080-03	02-6080-03	02-6080-03
23	Vertical Bolt Washer	4	15-6720-08	02-6730-03	02-6730-03	08-6720-07-70	15-6720-08	02-6730-03	02-6730-03	08-6720-07-70
24	Vertical Bolt Nut	4	02-6430-08	02-6430-03	02-6430-03	02-6680-03-70	02-6430-08	02-6430-03	02-6430-03	02-6680-03-70
25	Diaphragm	2	*	*	*	02-1010-56	*	*	*	02-1010-56
26	Valve Ball	4	*	*	*	02-1080-56	*	*	*	02-1080-56
27	Valve Seat	4	*	*	*	02-1120-03	*	*	*	02-1120-03
28	Valve Seat O-Ring	4	*	*	*	02-1200-56	*	*	*	02-1200-56
29	Shaft Stud	2	N/R	02-6150-08	02-6150-08	02-6150-08	N/R	02-6150-08	02-6150-08	02-6150-08
P2 Bolted										
30	Assy., Center Section, P2	1	02-3142-20	02-3142-20	02-3142-20	02-3142-20				
31	Liquid Chamber, Hybrid	2	02-5005-01	02-5005-03	02-5005-04	02-5005-03				
32	Screw, Liquid Chamber	16	95-6011-08	08-6180-03-42	08-6180-03-42	08-6180-03-42				
33	Washer, Flat, .344 x .688 x .065	16	N/R	02-6731-03	02-6731-03	02-6731-03				

¹Air Valve Assembly includes items 2 and 3.*Refer to corresponding elastomer chart in Section 9.

NOTE: Item #6 is not required for bolted version.

Item numbers 30-33 for P2 Bolted configuration.

0070 Specialty Code = Saniflo^{FD}A

0720 Specialty Code = Hybrid

0721 Specialty Code = Hybrid BSP

0722 Specialty Code = Hybrid Saniflo (Not available with aluminum wetted components)

All boldface items are primary wear parts.

EXPLODED VIEW AND PARTS LISTING

P2 METAL

PTFE-Fitted

EXPLODED VIEW

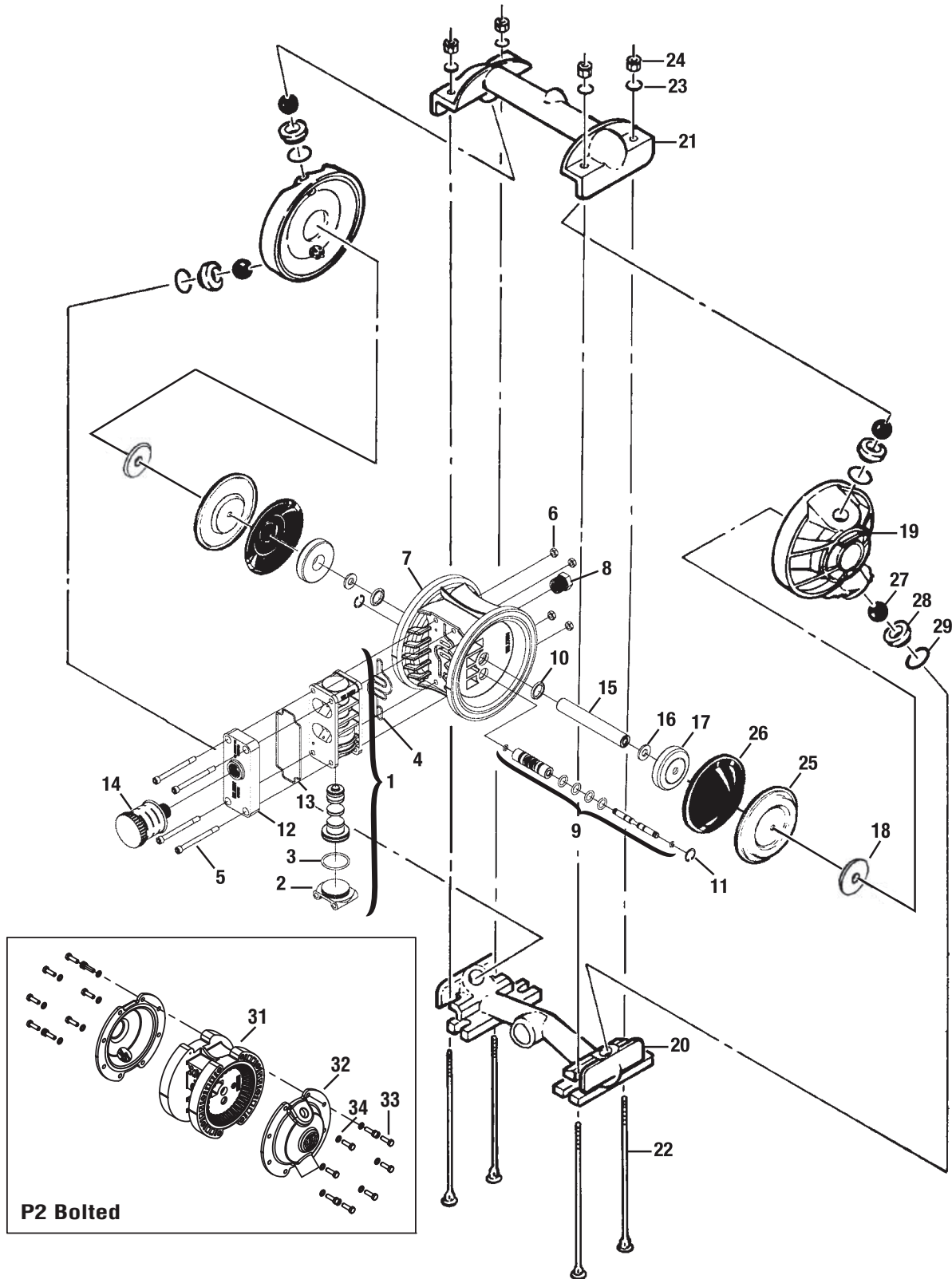

EXPLODED VIEW AND PARTS LISTING

P2 METAL

PTFE-Fitted

PARTS LISTING

Item	Part Description	Qty. Per Pump	Polypropylene Center Section				Acetal Center Section			
			P2/AAPPP P/N	P2/SSPPP P/N	P2/HHPPP P/N	P2/SSPPP/0070 P/N	P2/AALLL P/N	P2/SSLLL P/N	P2/HHLLL P/N	P2/SSLLL/0070 P/N
1	Pro-Flo® Air Valve Assembly¹	1	01-2010-20	01-2010-20	01-2010-20	01-2010-20	01-2010-13	01-2010-13	01-2010-13	01-2010-13
2	End Cap	1	01-2332-20	01-2332-20	01-2332-20	01-2332-20	01-2332-13	01-2332-13	01-2332-13	01-2332-13
3	O-Ring, End Cap	1	01-2395-52	01-2395-52	01-2395-52	01-2395-52	01-2395-52	01-2395-52	01-2395-52	01-2395-52
4	Gasket, Air Valve	1	01-2615-52	01-2615-52	01-2615-52	01-2615-52	01-2615-52	01-2615-52	01-2615-52	01-2615-52
5	Screw, HHC, Air Valve 1/4"-20	4	01-6001-03	01-6001-03	01-6001-03	01-6001-03	01-6001-03	01-6001-03	01-6001-03	01-6001-03
6	Nut, Hex, 1/4"-20	4	04-6400-03	04-6400-03	04-6400-03	04-6400-03	04-6400-03	04-6400-03	04-6400-03	04-6400-03
7	Center Section Assembly	1	02-3145-20	02-3145-20	02-3145-20	02-3145-20	02-3145-13	02-3145-13	02-3145-13	02-3145-13
8	Bushing, Reducer	1	01-6950-20	01-6950-20	01-6950-20	01-6950-20	01-6950-13	01-6950-13	01-6950-13	01-6950-13
9	Removable Pilot Sleeve Assembly	1	02-3880-99	02-3880-99	02-3880-99	02-3880-99	02-3880-99	02-3880-99	02-3880-99	02-3880-99
10	Glyd™ Ring II	2	02-3210-55-225	02-3210-55-225	02-3210-55-225	02-3210-55-225	02-3210-55-225	02-3210-55-225	02-3210-55-225	02-3210-55-225
11	Retaining Ring	2	00-2650-03	00-2650-03	00-2650-03	00-2650-03	00-2650-03	00-2650-03	00-2650-03	00-2650-03
12	Muffler Plate	1	01-3181-20	01-3181-20	01-3181-20	01-3181-20	01-3181-13	01-3181-13	01-3181-13	01-3181-13
13	Gasket, Muffler Plate	1	01-3505-52	01-3505-52	01-3505-52	01-3505-52	01-3505-52	01-3505-52	01-3505-52	01-3505-52
14	Muffler	1	02-3510-99	02-3510-99	02-3510-99	02-3510-99	02-3510-99	02-3510-99	02-3510-99	02-3510-99
15	Shaft, Pro-Flo®	1	02-3840-03	02-3840-03	02-3840-03	02-3840-03	02-3840-03	02-3840-03	02-3840-03	02-3840-03
16	Disc Spring (Belleville Washer)	2	02-6802-08	02-6802-08	02-6802-08	02-6802-08	02-6802-08	02-6802-08	02-6802-08	02-6802-08
17	Inner Piston	2	02-3751-01	02-3751-01	02-3751-01	02-3751-01	02-3751-01	02-3751-01	02-3751-01	02-3751-01
18	Outer Piston	2	02-4600-01	02-4600-03	02-4600-04	02-4600-03	02-4600-01	02-4600-03	02-4600-04	02-4600-03
19	Liquid Chamber	2	02-5000-01	02-5000-03	02-5000-04	02-5000-03	02-5000-01	02-5000-03	02-5000-04	02-5000-03
20	Inlet Manifold	1	02-5080-01	02-5080-03	02-5080-04	02-5080-03-70	02-5080-01	02-5080-03	02-5080-04	02-5085-03-70
21	Discharge Manifold	1	02-5020-01	02-5020-03	02-5020-04	02-5020-03-70	02-5020-01	02-5020-03	02-5020-04	02-5025-03-70
22	Screw, SHCS (Chamber Bolt)	4	02-6080-08	02-6080-03	02-5080-03	02-6080-03	02-6080-08	02-6080-03	02-5080-03	02-6080-03
23	Vertical Bolt Washer	4	15-6720-08	02-6730-03	02-6730-03	08-6720-07-70	15-6720-08	02-6730-03	02-6730-03	08-6720-07-70
24	Vertical Bolt Nut	4	02-6430-08	02-6430-03	02-6430-03	02-6680-03-70	02-6430-08	02-6430-03	02-6430-03	02-6680-03-70
25	Diaphragm	2	02-1010-55	02-1010-55	02-1010-55	02-1010-56	02-1010-55	02-1010-55	02-1010-55	02-1010-56
26	Backup Diaphragm	2	02-1060-56	02-1060-56	02-1060-56	02-1060-56	02-1060-56	02-1060-56	02-1060-56	02-1060-56
27	Valve Ball	4	02-1080-55	02-1080-55	02-1080-55	02-1080-56	02-1080-55	02-1080-55	02-1080-55	02-1080-56
28	Valve Seat	4	02-1120-01	02-1120-03	02-1120-04	02-1120-03	02-1120-01	02-1120-03	02-1120-04	02-1120-03
29	Valve Seat O-Ring	4	02-1200-55	02-1200-55	02-1200-55	02-1200-56	02-1200-55	02-1200-55	02-1200-55	02-1200-56
P2 Bolted										
31	Assy., Center Section, P2 Hybrid	1	02-3142-20	02-3142-20	02-3142-20	02-3142-20				
32	Liquid Chamber, Hybrid	2	02-5005-01	02-5005-03	02-5005-04	02-5005-03				
33	Screw, SHCS, 5/16"-18 x 1"	16	95-6011-08	08-6180-03-42	08-6180-03-42	08-6180-03-42				
34	Washer, Flat, .344 x .688 x .065	16	N/R	02-6731-03	02-6731-03	02-6731-03				

¹Air Valve Assembly includes items 2 and 3.

NOTE: Item #6 is not required for bolted version.

Item numbers 30-33 for P2 Metal Bolted configuration.

*Refer to corresponding elastomer chart in Section 9.

0070 Specialty Code = Saniflo^{FDA}

0720 Specialty Code = Hybrid

0721 Specialty Code = Hybrid BSP

0722 Specialty Code = Hybrid Saniflo (Not available with aluminum wetted components)

All boldface items are primary wear parts.

ELASTOMER OPTIONS

P2 Metal Pumps

MATERIAL	DIAPHRAGM	VALVE BALL	VALVE SEAT/P/N	VALVE SEAT O-RING*
Polyurethane	02-1010-50	02-1080-50	N/A	02-1200-50
Buna-N	02-1010-52	02-1080-52	N/A	02-1200-52
Neoprene	02-1010-51	02-1080-51	N/A	N/A
EPDM	02-1010-54	02-1080-54	N/A	02-1200-54
Viton®	02-1010-53	02-1080-53	N/A	N/A
Wil-Flex™	02-1010-58	02-1080-58	N/A	02-1200-58
Saniflex™	02-1010-56	02-1080-56	N/A	02-1200-56
PTFE	02-1010-55	02-1080-55	N/A	02-1200-55
Stainless Steel	N/A	N/A	02-1120-03	N/A
Aluminum	N/A	N/A	02-1120-01	N/A
Alloy C	N/A	N/A	02-1120-04	N/A

PX2 Metal Pumps

MATERIAL	DIAPHRAGM	BACKUP DIAPHRAGM	VALVE BALL	VALVE SEAT	VALVE SEAT O-RING*
Polyurethane	02-1010-50	N/A	02-1080-50	N/A	02-1200-50
Neoprene	02-1010-51	02-1060-51	02-1080-51	N/A	N/A
Buna	02-1010-52	N/A	02-1080-52	N/A	02-1200-52
Viton®	02-1010-53	N/A	02-1080-53	N/A	02-1200-53
Nordel	02-1010-54	02-1060-54	02-1080-54	N/A	02-1200-54
Teflon® PTFE	02-1010-55	N/A	02-1080-55	N/A	02-1200-55
Saniflex™	02-1010-56	02-1060-56	02-1080-56	N/A	02-1200-56
Wil-Flex™	02-1010-58	N/A	02-1080-58	N/A	02-1200-58
Aluminum	N/A	N/A	N/A	02-1120-01	N/A
Stainless Steel Teflon® FFT	02-1040-55	02-1065-57	02-1080-55	02-1120-03	02-1200-55

WARRANTY

Each and every product manufactured by Wilden Pump and Engineering, LLC is built to meet the highest standards of quality. Every pump is functionally tested to insure integrity of operation.

Wilden Pump and Engineering, LLC warrants that pumps, accessories and parts manufactured or supplied by it to be free from defects in material and workmanship for a period of five (5) years from date of installation or six (6) years from date of manufacture, whichever comes first. Failure due to normal wear, misapplication, or abuse is, of course, excluded from this warranty.

Since the use of Wilden pumps and parts is beyond our control, we cannot guarantee the suitability of any pump or part for a particular application and Wilden Pump and Engineering, LLC shall not be liable for any consequential damage or expense arising from the use or misuse of its products on any application. Responsibility is limited solely to replacement or repair of defective Wilden pumps and parts.

All decisions as to the cause of failure are the sole determination of Wilden Pump and Engineering, LLC.

Prior approval must be obtained from Wilden for return of any items for warranty consideration and must be accompanied by the appropriate MSDS for the product(s) involved. A Return Goods Tag, obtained from an authorized Wilden distributor, must be included with the items which must be shipped freight prepaid.

The foregoing warranty is exclusive and in lieu of all other warranties expressed or implied (whether written or oral) including all implied warranties of merchantability and fitness for any particular purpose. No distributor or other person is authorized to assume any liability or obligation for Wilden Pump and Engineering, LLC other than expressly provided herein.

PLEASE PRINT OR TYPE AND FAX TO WILDEN

PUMP INFORMATION			
Item # _____		Serial # _____	
Company Where Purchased _____			
YOUR INFORMATION			
Company Name _____			
Industry _____			
Name _____		Title _____	
Street Address _____			
City _____		State _____	Postal Code _____
Country _____			
Telephone _____		Fax _____	Web Address _____
E-mail _____			
Number of pumps in facility? _____		Number of Wilden pumps? _____	
Types of pumps in facility (check all that apply): <input type="checkbox"/> Diaphragm <input type="checkbox"/> Centrifugal <input type="checkbox"/> Gear <input type="checkbox"/> Submersible <input type="checkbox"/> Lobe			
<input type="checkbox"/> Other _____			
Media being pumped? _____			
How did you hear of Wilden Pump? <input type="checkbox"/> Trade Journal <input type="checkbox"/> Trade Show <input type="checkbox"/> Internet/E-mail <input type="checkbox"/> Distributor			
<input type="checkbox"/> Other _____			

ONCE COMPLETE, FAX TO (909) 783-3440

NOTE: WARRANTY VOID IF PAGE IS NOT FAXED TO WILDEN

WILDEN PUMP & ENGINEERING, LLC

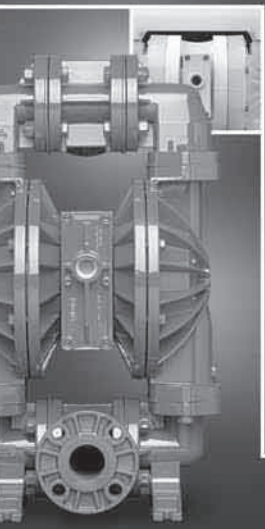

ADVANCED S E R I E S

Advance Your Process

- Advanced wetted path designs
- Lower the cost of operation
- Maximize product containment
- Longer MTBF (Mean Time Between Failures)
- Enhanced internal clearance
- The result of advanced thought

UNITEC S E R I E S

Enrich Your Process

- Simplicity of design
- Unique Technology
- Reliable, leak-free & quiet
- Validated & certified
- Intrinsically safe
- The result of unique thought

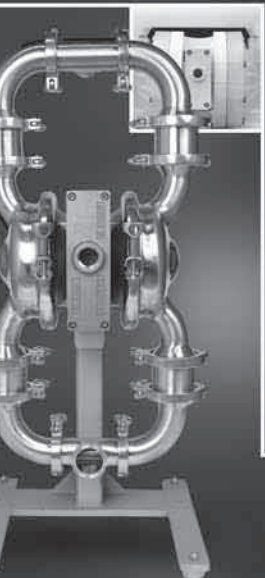
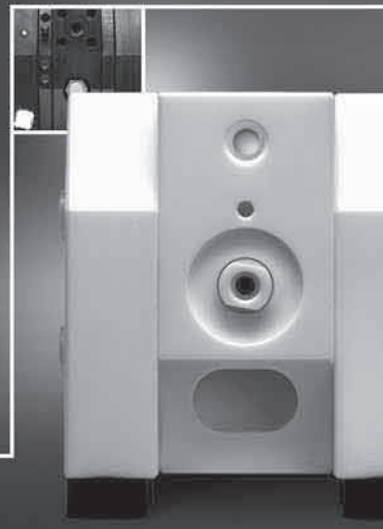

SANIFLO S A N I T A R Y P U M P T E C H N O L O G Y

Refine Your Process

- Designed for sanitary applications
- Minimize product degradation
- Improved production yields
- Easy to inspect, clean & assemble
- Minimized water requirements
- The result of progressive thought

ACCESSORIES

Maximize Your Process

- Electronic control & monitoring
- Level control & containment
- Pulsation dampening
- Drum unloading systems
- Complete system solutions
- The result of innovative thought

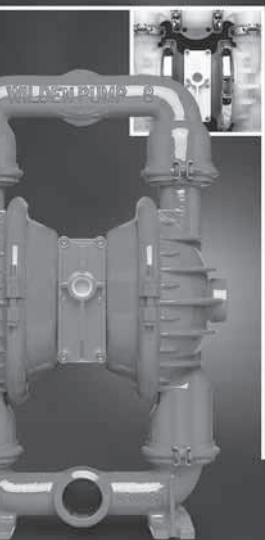

ORIGINAL S E R I E S

Simplify Your Process

- Long standing design simplicity
- Portable & submersible
- Variable connection options
- Fewest parts in industry
- Solutions since 1955
- The result of original thought



WILDEN[®]

A **DOVER** COMPANY

22069 VAN BUREN STREET • GRAND TERRACE, CA 92313-5607
(909) 422-1730 • FAX (909) 783-3440
www.wildenpump.com

Your Local Authorized Distributor: