

# EOM

ENGINEERING OPERATION  
& MAINTENANCE

# T4 Clamped Metal Pump



Where Innovation Flows

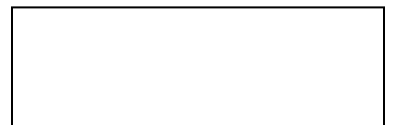

## Contents

<b>Section 1: Precautions - Read First!</b> .....	<b>4</b>
<b>Section 2: Wilden Pump Designation System</b> .....	<b>5</b>
<b>Section 3: How It Works</b> .....	<b>6</b>
<b>Section 4: Dimensional Drawings</b> .....	<b>7</b>
<b>Section 5: Performance</b> .....	<b>8</b>
T4 Metal Rubber-Fitted.....	8
T4 Metal TPE-Fitted.....	8
T4 Ultra-Flex™-Fitted.....	9
Suction-Lift Capability.....	10
<b>Section 6: Suggested Installation, Operation, Maintenance and Troubleshooting</b> .....	<b>11</b>
<b>Section 7: Disassembly / Reassembly</b> .....	<b>14</b>
Pump Disassembly.....	14
Air Valve Disassembly.....	17
Gasket Kit Installation.....	20
<b>Section 8: Exploded View and Parts List</b> .....	<b>21</b>
T4 Metal Rubber/TPE-Fitted.....	21
<b>Section 9: Elastomer Options</b> .....	<b>23</b>

**Copyright**

Copyright 2018 PSG®, a Dover Company. All rights reserved.

PSG reserves the right to modify the information and illustrations in this document without prior notice. The product described in this document is furnished under a license agreement or nondisclosure agreement. No part of this document may be reproduced, stored in a retrieval system, or transmitted in any form or any means electronic or mechanical, including photocopying and recording, without the written permission of PSG, a Dover Company, except as described by the terms of those agreements.

This is a non-contractual document. 01-2019.

**Trademarks**

PSG and the PSG logo are registered trademarks of PSG. Wilden® is a registered trademark of PSG California LLC. Pro-Flo® SHIFT and Pro-Flo® are registered trademarks of PSG California LLC. Wil-Flex® is a trademark of PSG California LLC. Saniflex™ is a trademark of PSG California LLC.

All trademarks, names, logos and service marks (collectively "trademarks") in this document are registered and unregistered trademarks of their respective owners. Nothing contained in this document should be construed as granting any license or right to use any trademark without the prior written permission of the trademark owner.

**Warranty**

Each and every product manufactured by Wilden is built to meet the highest standards of quality. Every pump is functionally tested to ensure integrity of operation. Wilden warrants that pumps, accessories and parts manufactured or supplied by it to be free from defects in material and workmanship for a period of five (5) years from date of installation or six (6) years from date of manufacture, whichever comes first.

For more information, and to register your Wilden pump for warranty, please visit <https://www.psgdover.com/wilden/support/warranty-registration>.

**Certifications**

**Section 1**

**Precautions - Read First!**



**TEMPERATURE LIMITS:**

Polypropylene	0°C to 79°C	32°F to 175°F
PVDF	-12°C to 107°C	10°F to 225°F
Neoprene	-17.8°C to 93.3°C	0°F to 200°F
Buna-N	-12.2°C to 82.2°C	10°F to 180°F
EPDM	-51.1°C to 137.8°C	-60°F to 280°F
FKM®	-40°C to 176.7°C	-40°F to 350°F
Wil-Flex™	-40°C to 107.2°C	-40°F to 225°F
Polyurethane	12.2°C to 65.6°C	10°F to 150°F
Saniflex™	-28.9°C to 104.4°C	-20°F to 220°F
PTFE	4.4°C to 104.4°C	40°F to 220°F

**NOTE:** Not all materials are available for all models. See "Wilden Pump Designation System" on page 5 for material options for your pump.



**CAUTION:** When choosing pump materials, be sure to check the temperature limits for all wetted components. Example: FKM® has a maximum limit of 176.7°C (350°F) but polypropylene has a maximum limit of only 79°C (175°F).



**CAUTION:** Maximum temperature limits are based upon mechanical stress only. Certain chemicals will significantly reduce maximum safe operating temperatures. Consult engineering guide for chemical compatibility and temperature limits.



**CAUTION:** Always wear safety glasses when operating pump. If diaphragm rupture occurs, material being pumped may be forced out air exhaust.



**WARNING:** Prevention of static sparking — If static sparking occurs, fire or explosion could result. Pump, valves, and containers must be properly grounded when handling flammable fluids and whenever discharge of static electricity is a hazard.



**CAUTION:** Do not exceed 8.6 bar (125 psig) air supply pressure.



**CAUTION:** Before any maintenance or repair is attempted, the compressed air line to the pump should be disconnected and all air pressure allowed to bleed from pump. Disconnect all intake, discharge and air lines. Drain the pump by turning it upside down and allowing any fluid to flow into a suitable container.



**CAUTION:** Blow out air line for 10 to 20 seconds before attaching to pump to make sure all pipe line debris is clear. Use an in-line air filter. A 5µ (micron) air filter is recommended.



**NOTE:** When installing PTFE diaphragms, it is important to tighten outer pistons simultaneously (turning in opposite directions) to ensure tight fit.



**NOTE:** Tighten clamp bands and retainers prior to installation. Fittings may loosen during transportation.



**NOTE:** Before starting disassembly, mark a line from each liquid chamber to its corresponding air chamber. This line will assist in proper alignment during reassembly.



**CAUTION:** Verify the chemical compatibility of the process and cleaning fluid to the pump's component materials in the Chemical Resistance Guide (see E4).



**CAUTION:** When removing the end cap using compressed air, the air valve end cap may come out with considerable force. Hand protection such as a padded glove or rag should be used to capture the end cap.



**CAUTION:** Only explosion proof (NEMA 7) solenoid valves should be used in areas where explosion proof equipment is required.



**NOTE:** All non lube-free air-operated pumps must be lubricated. Wilden suggests an arctic 5 weight oil (ISO grade 15). Do not over-lubricate pump. Over-lubrication will reduce pump performance.



**NOTE:** On cast iron pumps equipped with PTFE diaphragms, balls and sealing rings, PTFE gasket kits should be utilized.



**NOTE:** UL-listed pumps must not exceed 3.4 bar (50 psig) air supply pressure.

**Section 2**

**WILDEN PUMP DESIGNATION SYSTEM**

**T4 ORIGINAL™**  
**METAL**

**38 mm (1-1/2") Pump**  
**Maximum Flow Rate:**  
**307 lpm (81 gpm)**

**LEGEND**

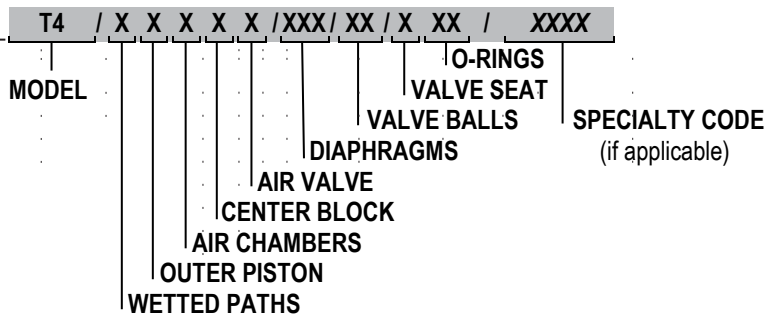

**MATERIAL CODES**

**MODEL**

T4 = 38 MM (1-1/2")

**WETTED PATH**

A = ALUMINUM  
W = DUCTILE IRON

**OUTER PISTON**

A = ALUMINUM  
M = MILD STEEL  
S = STAINLESS STEEL  
W = DUCTILE IRON

**AIR CHAMBER**

A = ALUMINUM  
M = MILD STEEL  
P = POLYPROPYLENE

**CENTER BLOCK**

A = ALUMINUM  
P = POLYPROPYLENE

**AIR VALVE**

B = BRASS

**DIAPHRAGMS**

BNS = BUNA-N (Red Dot)  
BNU = BUNA-N, ULTRA-FLEX™ (Red Dot)  
EPS = EPDM (Blue Dot)  
EPU = EPDM, ULTRA-FLEX™ (Blue Dot)  
FSS = SANIFLEX™ [Hytrel® (Cream)]  
NES = NEOPRENE (Green Dot)  
NEU = NEOPRENE, ULTRA-FLEX™ (Green Dot)  
PUS = POLYURETHANE (Clear)  
TEU = PTFE W/EPDM BACK-UP (White)  
TNU = PTFE W/NEOPRENE BACK-UP (White)  
TSU = PTFE W/SANIFLEX™ BACK-UP (White)  
VTS = FKM® (White Dot)  
VTU = FKM®, ULTRA-FLEX™ (White Dot)  
WFS = WIL-FLEX™ [Santoprene® (Orange Dot)]

**VALVE BALLS**

BN = BUNA-N (Red Dot)  
EP = EPDM (Blue Dot)  
FS = SANIFLEX™ [Hytrel® (Cream)]  
NE = NEOPRENE (Green Dot)  
PU = POLYURETHANE (Brown)  
TF = PTFE (White)  
VT = FKM® (White Dot)  
WF = WIL-FLEX™ [Santoprene® (Orange Dot)]

**VALVE SEATS**

A = ALUMINUM  
BN = BUNA-N (Red Dot)  
EP = EPDM (Blue Dot)  
FS = SANIFLEX™ [Hytrel® (Cream)]  
M = MILD STEEL\*  
NE = NEOPRENE (Green Dot)  
PU = POLYURETHANE (Brown)  
S = STAINLESS STEEL\*  
VT = FKM® (White Dot)  
WF = WIL-FLEX™ [Santoprene® (Orange Dot)]

**VALVE SEATS O-RINGS**

TF = PTFE (White)

\*No valve seat o-ring required.

**SPECIALTY CODES**

0014	BSPT	0048	Stallion®, internals
0030	Screen based	0050	Stallion
0036	Screen based, BSPT	0051	Stallion®, BSPT
0044	Stallion®, balls & seats ONLY	0113	Stallion®, internals, spark free, BSPT
0045	Stallion®, shaft & bumpers ONLY	0231	Stallion®, externals (screen)
0046	Stallion®, internals, BSPT	0233	Stallion®, externals (screen), BSPT

**NOTE:** Most Elastomeric Materials use colored dots for identification.

**NOTE:** Not all models are available with all material options.

FKM® is a registered trademarks of DuPont Dow Elastomers.

Santoprene® is a registered trademark of Monsanto Company, licensed to Advanced Elastomer Systems, L.P.

Hytrel® is a registered trademark of DuPont Dow Elastomers.

**Section 3**

**HOW IT WORKS — PUMP**

The Wilden diaphragm pump is an air-operated, positive displacement, self-priming pump. These drawings show the flow pattern through the pump upon its initial stroke. It is assumed the pump has no fluid in it prior to its initial stroke.

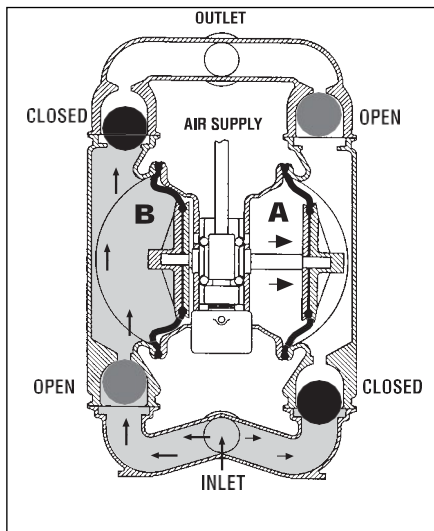

**FIGURE 1** The air valve directs pressurized air to the back side of diaphragm A. The compressed air is applied directly to the liquid column separated by elastomeric diaphragms. The diaphragm acts as a separation membrane between the compressed air and liquid, balancing the load and removing mechanical stress from the diaphragm. The compressed air moves the diaphragm away from the center block of the pump. The opposite diaphragm is pulled in by the shaft connected to the pressurized diaphragm. Diaphragm B is on its suction stroke; air behind the diaphragm has been forced out to the atmosphere through the exhaust port of the pump. The movement of diaphragm B toward the center block of the pump creates a vacuum within chamber B. Atmospheric pressure forces fluid into the inlet manifold forcing the inlet valve ball off its seat. Liquid is free to move past the inlet valve ball and fill the liquid chamber (see shaded area).

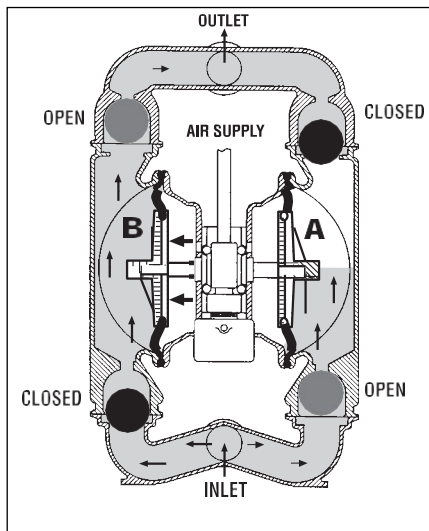

**FIGURE 2** When the pressurized diaphragm, diaphragm A, reaches the limit of its discharge stroke, the air valve redirects pressurized air to the back side of diaphragm B. The pressurized air forces diaphragm B away from the center block while pulling diaphragm A to the center block. Diaphragm B is now on its discharge stroke. Diaphragm B forces the inlet valve ball onto its seat due to the hydraulic forces developed in the liquid chamber and manifold of the pump. These same hydraulic forces lift the discharge valve ball off its seat, forcing fluid to flow through the pump discharge. The movement of diaphragm A toward the center block of the pump creates a vacuum within liquid chamber A. Atmospheric pressure forces fluid into the inlet manifold of the pump. The inlet valve ball is forced off its seat allowing the fluid being pumped to fill the liquid chamber.

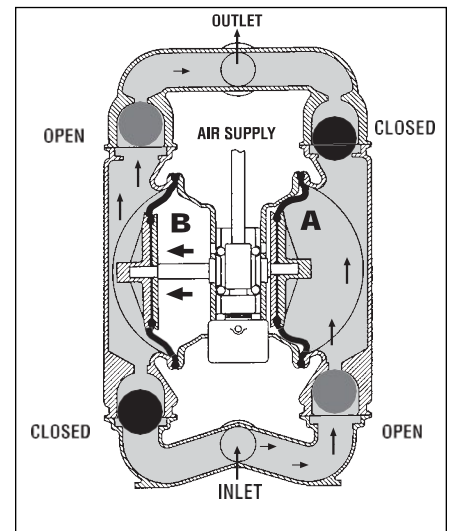
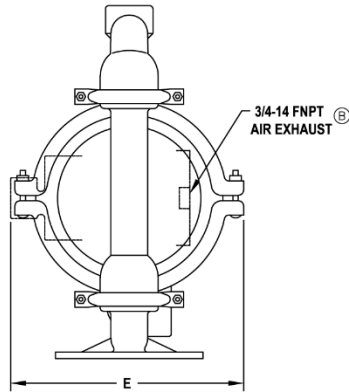
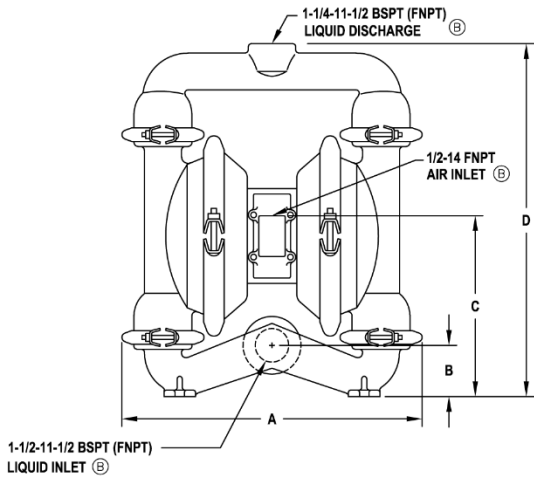

**FIGURE 3** At completion of the stroke, the air valve again redirects air to the back side of diaphragm A, which starts diaphragm B on its exhaust stroke. As the pump reaches its original starting point, each diaphragm has gone through one exhaust and one discharge stroke. This constitutes one complete pumping cycle. The pump may take several cycles to completely prime depending on the conditions of the application.

**Section 4**

**DIMENSIONAL DRAWING**

**T4 Metal**



DIMENSIONS - T4 (METAL)		
ITEM	METRIC (mm)	STANDARD (inch)
A	368	14.5
B	64	2.5
C	221	8.7
D	429	16.9
E	287	11.3
F	262	10.3
G	224	8.8
H	150	5.9
J	178	7.0
K	51	2.0
L	10	0.4
M	338	13.3
N	224	8.8
P	155	6.1
R	196	7.7
S	48	1.9
T	13	0.5

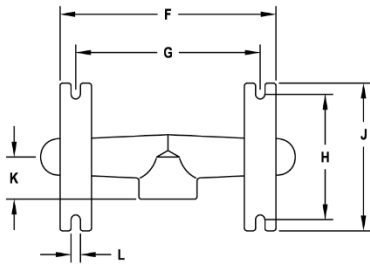

FOOTED BASE FOR  
STAINLESS STEEL MODELS

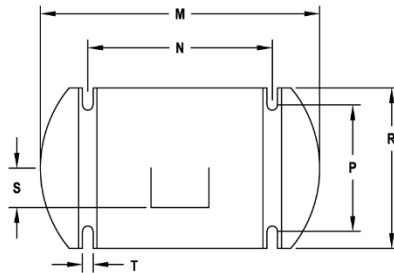

BASE FOR ALUMINUM &  
CAST IRON MODELS

LW0386 REV. B

**Section 5**

**PERFORMANCE**

**T4 METAL  
RUBBER-FITTED**

Height ..... 442 mm (17.4")  
 Width ..... 391 mm (15.4")  
 Depth ..... 285 mm (11.2")  
 Est. Ship Weight... Aluminum 17 kg (38 lbs)  
                                   Stainless Steel 26 kg (57 lbs)  
                                   Cast Iron 26 kg (57 lbs)  
 Air Inlet..... 13 mm (1/2")  
 Inlet..... 38 mm (1-1/2")  
 Outlet ..... 32 mm (1-1/4")  
 Suction Lift ..... 5.49 m (18')  
                                   8.53 m (28')  
 Disp. Per Stroke<sup>1</sup>..... 1.02 l (0.27 gal.)  
 Max. Flow Rate..... 288 lpm (76 gpm)  
 Max. Size Solids..... 4.8 mm (3/16")

<sup>1</sup>Displacement per stroke was calculated at 4.8 bar (70 psig) air inlet pressure against a 2 bar (30 psig) head pressure.

**Example:** To pump 113.6 lpm (30 gpm) against a discharge pressure head of 2.7 bar (40 psig) requires 4.1 bar (60 psig) and 25.5 Nm<sup>3</sup>/h (15 scfm) air consumption. (See dot on chart.)

**Caution:** Do not exceed 8.6 bar (125 psig) air supply pressure.

**T4 METAL  
TPE-FITTED**

Height ..... 442 mm (17.4")  
 Width ..... 391 mm (15.4")  
 Depth ..... 285 mm (11.2")  
 Est. Ship Weight... Aluminum 17 kg (38 lbs)  
                                   Stainless Steel 26 kg (57 lbs)  
                                   Cast Iron 26 kg (57 lbs)  
 Air Inlet..... 13 mm (1/2")  
 Inlet..... 38 mm (1-1/2")  
 Outlet ..... 32 mm (1-1/4")  
 Suction Lift ..... 4.27 m Dry (14')  
                                   8.23 m Wet (27')  
 Disp. Per Stroke<sup>1</sup>..... 1.17 l (0.31 gal.)  
 Max. Flow Rate..... 307 lpm (81 gpm)  
 Max. Size Solids..... 4.8 mm (3/16")

<sup>1</sup>Displacement per stroke was calculated at 70 psig (4.8 bar) air inlet pressure against a 2 bar (30 psig) head pressure.

**Example:** To pump 113.6 lpm (30 gpm) against a discharge pressure head of 2.7 bar (40 psig) requires 4.1 bar (60 psig) and 25.5 Nm<sup>3</sup>/h (15 scfm) air consumption. (See dot on chart.)

**Caution:** Do not exceed 8.6 bar (125 psig) air supply pressure.

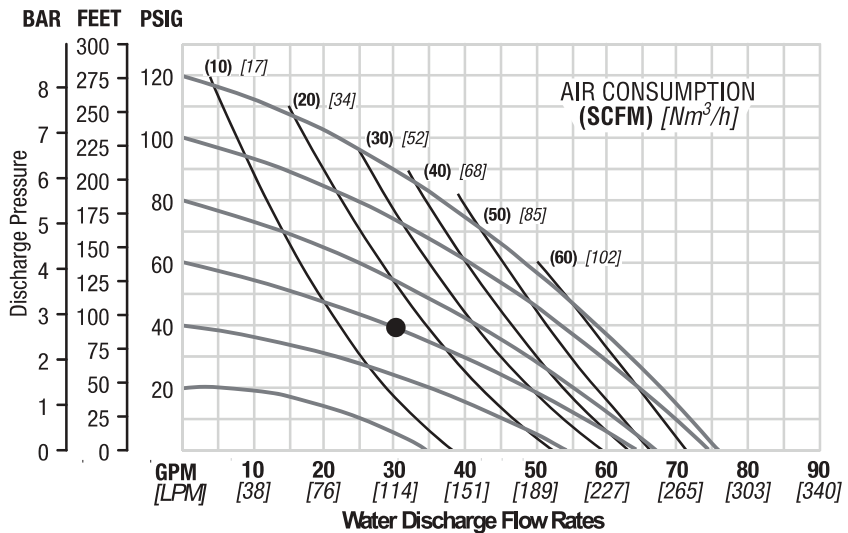

Flow rates indicated on chart were determined by pumping water.

For optimum life and performance, pumps should be specified so that daily operation parameters will fall in the center of the pump performance curve.

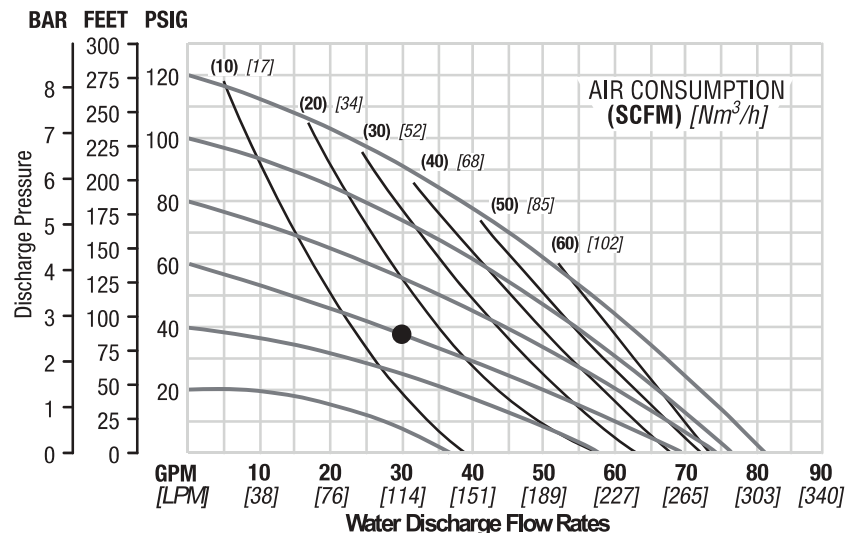

Flow rates indicated on chart were determined by pumping water.

For optimum life and performance, pumps should be specified so that daily operation parameters will fall in the center of the pump performance curve.

**PERFORMANCE**

**T4 METAL  
PTFE-FITTED**

Height ..... 442 mm (17.4")  
 Width ..... 391 mm (15.4")  
 Depth ..... 285 mm (11.2")  
 Est. Ship Weight... Aluminum 17 kg (38 lbs)  
                                   Stainless Steel 26 kg (57 lbs)  
                                   Cast Iron 26 kg (57 lbs)  
 Air Inlet..... 13 mm (1/2")  
 Inlet..... 38 mm (1-1/2")  
 Outlet ..... 32 mm (1-1/4")  
 Suction Lift ..... 2.74 m Dry (9')  
                                   8.53 m Wet (28')  
 Disp. Per Stroke<sup>1</sup>.....0.53 l (0.14 gal.)  
 Max. Flow Rate..... 235 lpm (62 gpm)  
 Max. Size Solids..... 4.8 mm (3/16")

<sup>1</sup>Displacement per stroke was calculated at 4.8 bar (70 psig) air inlet pressure against a 2 bar (30 psig) head pressure.

**Example:** To pump 94.6 lpm (25 gpm) against a discharge pressure head of 2.7 bar (40 psig) requires 4.1 bar (60 psig) and 51 Nm<sup>3</sup>/h (30 scfm) air consumption. (See dot on chart.)

**Caution:** Do not exceed 8.6 bar (125 psig) air supply pressure.

**T4 METAL STALLION  
ULTRA-FLEX™-FITTED**

Height ..... 449 mm (17.7")  
 Width ..... 391 mm (15.4")  
 Depth ..... 285 mm (11.2")  
 Est. Ship Weight... Aluminum 20 kg (44 lbs)  
                                   Stainless Steel 26 kg (57 lbs)  
                                   Cast Iron 26 kg (57 lbs)  
 Air Inlet..... 13 mm (1/2")  
 Inlet..... 38 mm (1-1/2")  
 Outlet ..... 32 mm (1-1/4")  
 Suction Lift ..... 4.27 m Dry (14')  
                                   8.23 m Wet (27')  
 Disp. Per Stroke<sup>1</sup>.....0.64 l (0.17 gal.)  
 Max. Flow Rate..... 216 lpm (57 gpm)  
 Max. Size Solids..... 13 mm (1/2")

<sup>1</sup>Displacement per stroke was calculated at 4.8 bar (70 psig) air inlet pressure against a 2 bar (30 psig) head pressure.

**Example:** To pump 98.4 lpm (26 gpm) against a discharge pressure head of 2.7 bar (40 psig) requires 4.1 bar (60 psig) and 35.7 Nm<sup>3</sup>/h (21 scfm) air consumption. (See dot on chart.)

**Caution:** Do not exceed 8.6 bar (125 psig) air supply pressure.

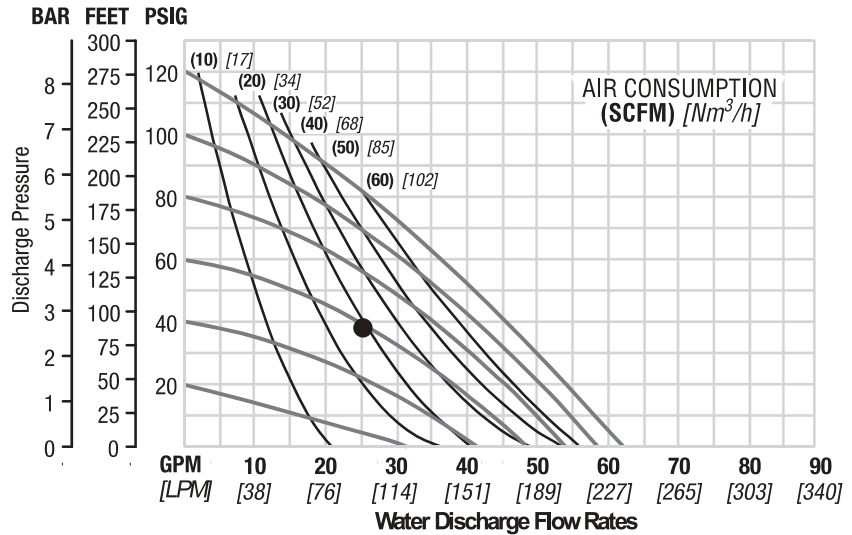

Flow rates indicated on chart were determined by pumping water.

For optimum life and performance, pumps should be specified so that daily operation parameters will fall in the center of the pump performance curve.

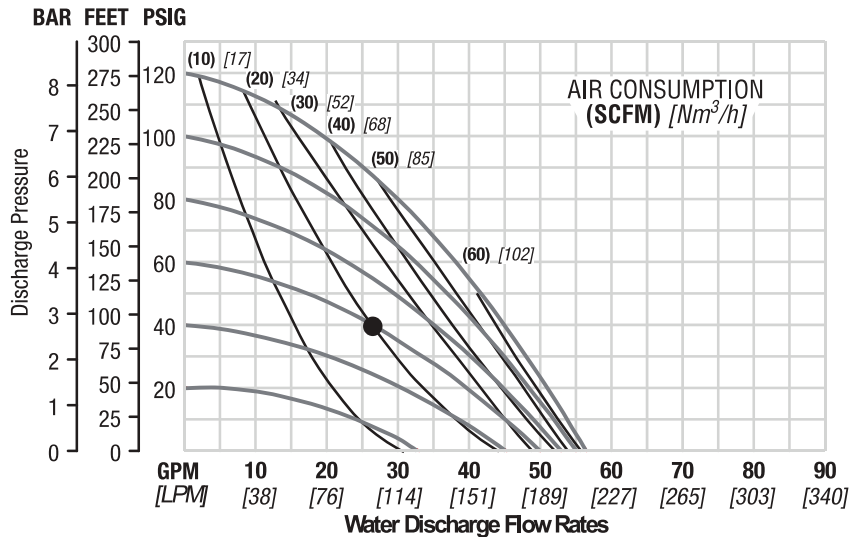

Flow rates indicated on chart were determined by pumping water.

For optimum life and performance, pumps should be specified so that daily operation parameters will fall in the center of the pump performance curve.

## SUCTION LIFT CURVES

### T4 METAL SUCTION-LIFT CAPABILITY

Suction lift curves are calibrated for pumps operating at 1,000' (305 m) above sea level. This chart is meant to be a guide only. There are many variables which can affect your pump's operating characteristics. The number of intake and discharge elbows, viscosity of pumping fluid, elevation (atmospheric pressure) and pipe friction loss all affect the amount of suction lift your pump will attain.

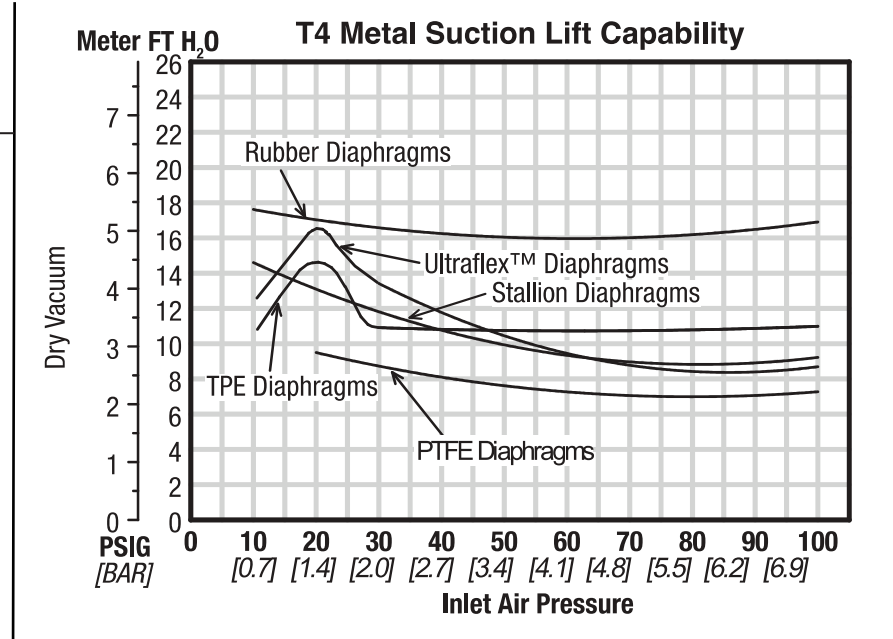

## Section 6

# Suggested Installation, Operation, Maintenance and Troubleshooting

The Model T4 Metal pump has a 38 mm (1-1/2") inlet and 32 mm (1-1/4") outlet and is designed for flows to 307 lpm (81 gpm). The T4 Metal pump is manufactured with wetted parts of aluminum, cast iron, or stainless steel. The T4 Metal pump comes with either a center block or center section. The T4 center block is constructed of aluminum or nickel-plated aluminum. The T4 center section comes in polypropylene. The air distribution system consists of a brass air valve body, aluminum piston, Glyd™ rings and a bronze center section bushing. A variety of diaphragms, valve balls, valve seats, and o-rings are available to satisfy temperature, chemical compatibility, abrasion and flex concerns.

The suction pipe size should be at least 13 mm (1/2") diameter or larger if highly viscous material is being pumped. The suction hose must be non-collapsible, reinforced type as the T4 is capable of pulling a high vacuum. Discharge piping should be at least 32 mm (1-1/4"); larger diameter can be used to reduce friction losses. It is critical that all fittings and connections are airtight or a reduction or loss of pump suction capability will result.

### Installation

Months of careful planning, study, and selection efforts can result in unsatisfactory pump performance if installation details are left to chance.

Premature failure and long term dissatisfaction can be avoided if reasonable care is exercised throughout the installation process.

### Location

Noise, safety, and other logistical factors usually dictate that "utility" equipment be situated away from the production floor. Multiple installations with conflicting requirements can result in congestion of utility areas, leaving few choices for siting of additional pumps.

Within the framework of these and other existing conditions, every pump should be located in such a way that four key factors are balanced against each other to maximum advantage.

- **Access:** First of all, the location should be accessible. If it's easy to reach the pump, maintenance personnel will have an easier time carrying out routine inspections and adjustments. Should major repairs become necessary, ease of access can play a key role in speeding the repair process and reducing total downtime.
- **Air Supply:** Every pump location should have an air line large enough to supply the volume of air necessary to achieve the desired pumping rate (see pump performance chart). Use air pressure up to a maximum of 8.6 bar (125 psig) depending upon pumping requirements. The use of an air filter before the pump will ensure that the majority of any pipeline contaminants will be eliminated. For best results, the pumps should use an air filter, regulator, and lubricator system.
- **Elevation:** Selecting a site that is well within the pump's suction lift capability will assure that loss-of-prime troubles will be eliminated. In addition, pump efficiency can be adversely affected if proper attention is not given to elevation (see pump performance chart).
- **PIPING:** Final determination of the pump site should not be made until the piping problems of each possible location have been evaluated. The impact of current and future installations should be considered ahead of time to make sure that inadvertent restrictions are not created for any remaining sites.

The best choice possible will be a site involving the shortest and the straightest hook-up of suction and discharge piping. Unnecessary elbows, bends, and fittings should be avoided. Pipe sizes should be selected so as to keep friction losses within practical limits. All piping should be supported independently of the pump. In addition, it should line up without placing stress on the pump fittings.

Expansion joints can be installed to aid in absorbing the forces created by the natural reciprocating action of the pump. If the pump is to be bolted down to a solid foundation, a mounting pad placed between the pump and foundation will assist in minimizing pump vibration. Flexible connections between the pump and rigid piping will also assist in minimizing pump vibration. If quick-closing valves are installed at any point in the discharge system, or if pulsation within a system becomes a problem, a surge suppressor should be installed to protect the pump, piping and gauges from surges and water hammer.

When pumps are installed in applications involving flooded suction or suction head pressures, a gate valve should be installed in the suction line to permit closing of the line for pump service.

The T4 can be used in submersible applications only when both wetted and non-wetted portions are compatible with the material being pumped. If the pump is to be used in a submersible application, a hose should be attached to the pump's air exhaust and the exhaust air piped above the liquid level.

If the pump is to be used in a self-priming application, be sure that all connections are airtight and that the suction lift is within the pump's ability. Note: Materials of construction and elastomer material have an effect on suction lift parameters. Please refer to pump performance data.

Pumps in service with a positive suction head are most efficient when inlet pressure is limited to 0.5–0.7 bar (7–10 psig). Premature diaphragm failure may occur if positive suction is 0.8 bar (11 psig) and higher.

THE MODEL T4 WILL PASS 4.8 mm (3/16") SOLIDS. THE M4 STALLION WILL PASS 13 mm (1/2") SOLIDS. WHENEVER THE POSSIBILITY EXISTS THAT LARGER SOLID OBJECTS MAY BE SUCKED INTO THE PUMP, A STRAINER SHOULD BE USED ON THE SUCTION LINE.

**CAUTION: DO NOT EXCEED 8.6 BAR (125 PSIG) AIR SUPPLY PRESSURE.**

**BLOW OUT AIR LINE FOR 10 TO 20 SECONDS BEFORE ATTACHING TO PUMP TO MAKE SURE ALL PIPE LINE DEBRIS IS CLEAR. ALWAYS USE AN IN-LINE AIR FILTER.**

**PUMPS SHOULD BE THOROUGHLY FLUSHED WITH WATER BEFORE INSTALLING INTO PROCESS LINES. FDA AND USDA PUMPS SHOULD BE CLEANED AND/OR SANITIZED BEFORE USE ON EDIBLE PRODUCTS.**

## Suggested Installation, Operation, Maintenance and Troubleshooting

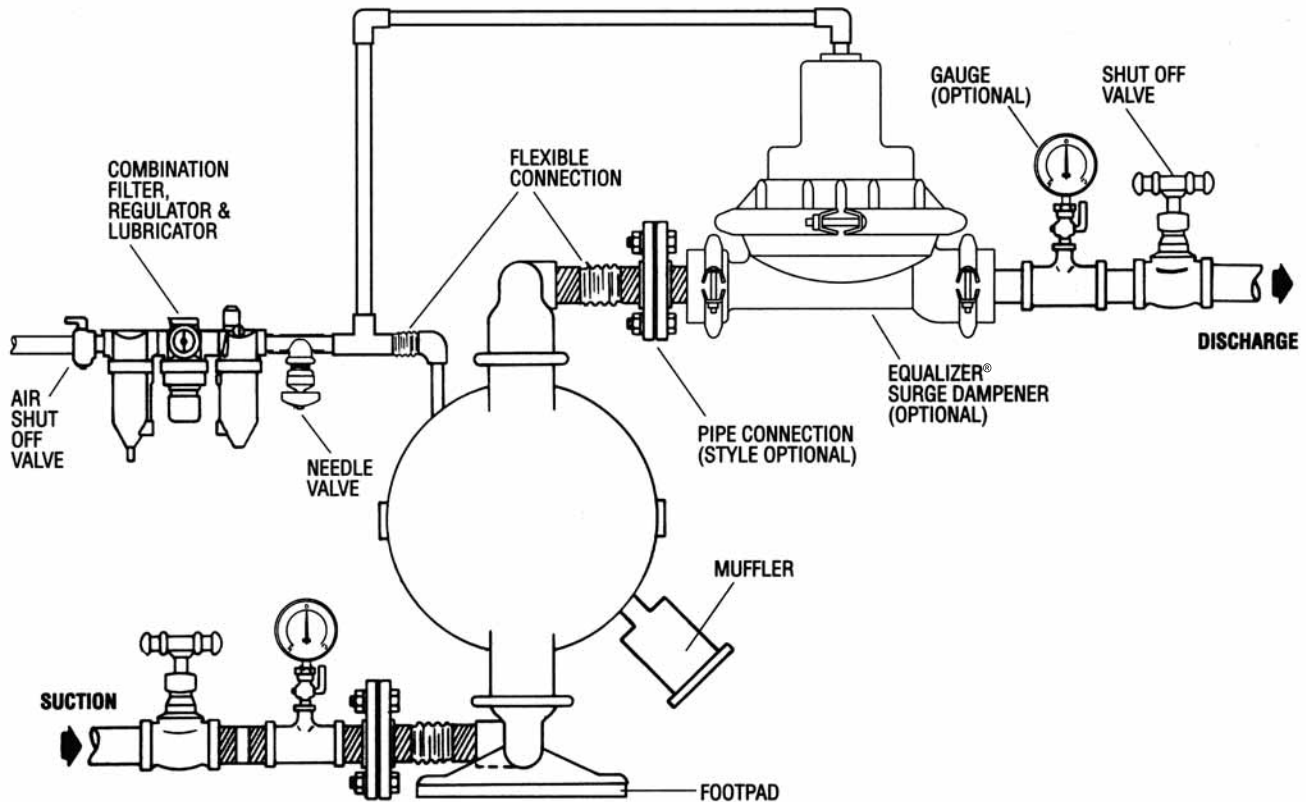

**NOTE:** In the event of a power failure, the shutoff valve should be closed, if the restarting of the pump is not desirable once power is regained.

**Air-Operated Pumps:** To stop the pump from operating in an emergency situation, simply close the “shut-off” valve (user supplied) installed in the air supply line. A properly functioning valve will stop the air supply to the pump, therefore stopping output. This shut-off valve should be located far enough away from the pumping equipment such that it can be reached safely in an emergency situation.

### Operation

Pump discharge rate can be controlled by limiting the volume and/or pressure of the air supply to the pump (preferred method). A regulator is used to regulate air pressure. A needle valve is used to regulate air volume. Pump discharge rate can also be controlled by throttling the pump discharge by partially closing a valve in the discharge line of the pump. This action increases friction loss which reduces flow rate. This is useful when the need exists to control the pump from a remote location. When the pump discharge pressure equals or exceeds the air supply pressure, the pump will stop; no bypass or pressure relief valve is needed, and pump damage will not occur. The pump has reached a “deadhead” situation and can be restarted by reducing the fluid discharge pressure or increasing the air inlet pressure. The Wilden T4 pump runs solely on compressed air and does not generate heat, therefore your process fluid temperature will not be affected.

### Maintenance and Inspections

Since each application is unique, maintenance schedules may be different for every pump. Frequency of use, line pressure, viscosity and abrasiveness of process fluid all affect the parts life of a Wilden pump. Periodic inspections have been found to offer the best means for preventing unscheduled pump downtime. Personnel familiar with the pump's construction and service should be informed of any abnormalities that are detected during operation.

### Records

When service is required, a record should be made of all necessary repairs and replacements. Over a period of time, such records can become a valuable tool for predicting and preventing future maintenance problems and unscheduled downtime. In addition, accurate records make it possible to identify pumps that are poorly suited to their applications.

## Suggested Installation, Operation, Maintenance and Troubleshooting

### Troubleshooting

#### ***Pump will not run or runs slowly.***

1. Check air inlet screen and air filter for debris.
2. Check for sticking air valve, flush air valve in solvent.
3. Check for worn out air valve. If piston face in air valve is shiny instead of dull, air valve is probably worn beyond working tolerances and must be replaced.
4. Check center block Glyd™ rings. If worn excessively, they will not seal and air will simply flow through pump and out air exhaust. Use only Wilden Glyd™ rings as they are of special construction and ISO 15-5 wt oil with arctic characteristics.
5. Check for rotating piston in air valve.
6. Check type of lubricant being used. A higher viscosity oil than suggested may cause the piston to stick or run erratically. Wilden suggests the use of a hydraulic oil with arctic characteristics (ISO 15-5 wt).

#### ***Pump runs, but little or no product flows.***

1. Check for pump cavitation; slow pump speed down to match thickness of material being pumped.
2. Check for sticking ball checks. If material being pumped is not compatible with pump elastomers, swelling may occur. Replace ball checks and o-rings with proper elastomers.

3. Check to make sure all suction connections are air tight, especially clamp bands around intake balls.

#### ***Pump air valve freezes.***

1. Check for excessive moisture in compressed air. Either install dryer or hot air generator for compressed air.

#### ***Air bubbles in pump discharge.***

1. Check for ruptured diaphragm.
2. Check tightness of clamp bands, especially at intake manifold.

#### ***Product comes out air exhaust.***

1. Check for diaphragm rupture.
2. Check tightness of piston plates to shaft.

#### ***Pump rattles.***

1. See E9 Troubleshooting Guide.
2. Create false discharge head or suction lift.

## Section 7

# Disassembly / Reassembly

## Pump Disassembly

### Tools Required:

- Adjustable Wrench
- 1/2" Wrench
- 3/8" Box Wrench
- 3/16" Allen Wrench
- Vise equipped with soft jaws (such as plywood, plastic or other suitable material)



**CAUTION:** Before any maintenance or repair is attempted, the compressed air line to the pump should be disconnected and all air pressure allowed to bleed from the pump. Disconnect all intake, discharge, and air lines. Drain the pump by turning it upside down and allowing any fluid to flow into a suitable container. Be aware of any hazardous effects of contact with your process fluid.

The Wilden T4 has a 38 mm (1-1/2") inlet and 32 mm (1-1/4") outlet and is designed for flows up to 81 gpm (307 lpm). The model T4 is available in aluminum, cast iron, or 316 stainless steel wetted parts. The air valve is manufactured of brass, PTFE-coated brass, nickel-plated brass or stainless steel. All o-rings used in the pump are of a special material and shore hardness which should only be replaced with factory-supplied parts.



**NOTE:** The model used for these instructions incorporates rubber diaphragms, balls, and seats. Models with PTFE diaphragms, balls and seats are the same except where noted. The procedures for A4 Accu-Flo™ pumps are the same except for the air distribution system.

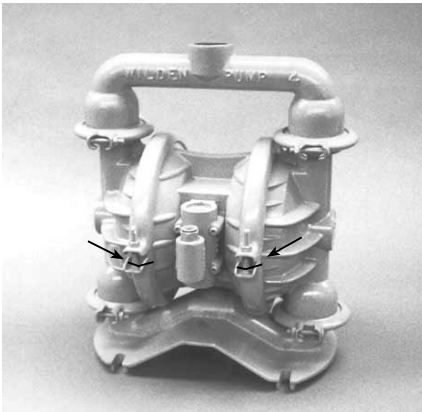

### Step 1

Before starting disassembly, mark a line from each liquid chamber to its corresponding air chamber. This line will assist in proper alignment during reassembly.

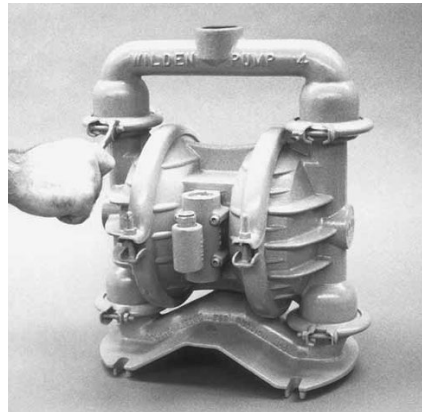

### Step 2

Utilizing a 1/2" wrench, remove the two small clamp bands that fasten the discharge manifold to the liquid chambers.

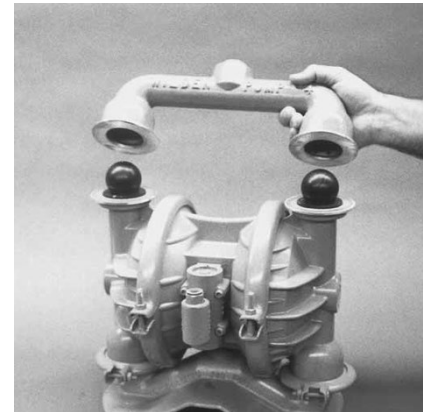

### Step 3

Lift away the discharge manifold to expose the valve balls and seats.

## Disassembly / Reassembly

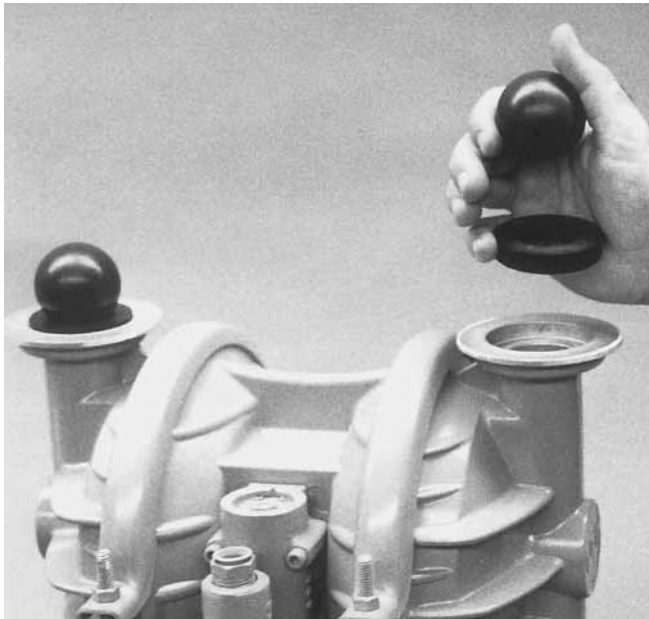

**Step 4**

Remove the discharge valve balls and seats from the liquid chambers and inspect for nicks, gouges, chemical attack or abrasive wear. Replace worn parts with genuine Wilden parts for reliable performance.

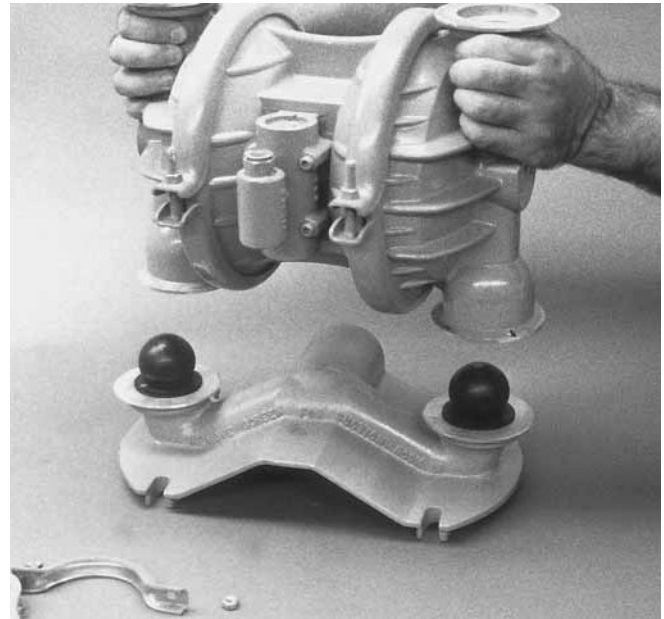

**Step 5**

Remove the two small clamp bands, which fasten the intake manifold to the liquid chambers. Lift liquid chambers and center section from intake manifold to expose intake valve balls and seats.

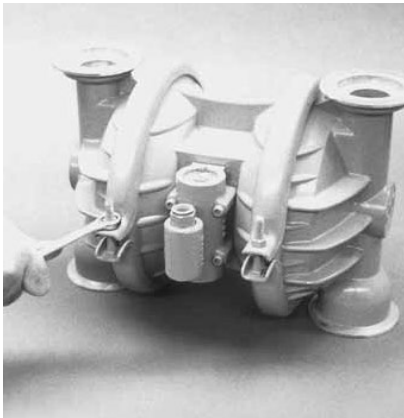

**Step 6**

Remove one set of large clamp bands which secure one liquid chamber to the center section.



**Step 7**

Lift liquid chamber away from center section to expose diaphragm and outer piston.



**Step 8**

Using an adjustable wrench, or by rotating the diaphragm by hand, remove the diaphragm assembly.

## Disassembly / Reassembly



### Step 9A



**NOTE:** Due to varying torque values, one of the following two situations may occur:

1) The outer piston, diaphragm and inner piston remain attached to the shaft and the entire assembly can be removed from the center section



### Step 9B

2) The outer piston, diaphragm and inner piston separate from the shaft which remains connected to the opposite side diaphragm assembly. Repeat disassembly instructions for the opposite liquid chamber. Inspect diaphragm assembly and shaft for signs of wear or chemical attack. Replace all worn parts with genuine Wilden parts for reliable performance.



### Step 10

To remove diaphragm assembly from shaft, secure shaft with soft jaws (a vise fitted with plywood or other suitable material) to ensure shaft is not nicked, scratched or gouged. Using an adjustable wrench, remove diaphragm assembly from shaft.

## Disassembly / Reassembly

### Air Valve / Center Section Disassembly

The air valve assembly consists of both the air valve body and piston and the center block. The unique design of the air valve relies only on differential pressure to effect the diaphragm shift. It is reliable and simple to maintain. The bushing in the center block, along with the diaphragm shaft, provides the “trigger” to tell the air valve to shift. The following procedure will ensure that the air valve on your Wilden pump will provide long trouble-free service.

#### AIR VALVE BODY AND PISTON ASSEMBLY AND DISASSEMBLY

The air valve (P/N 04-2000-07) can be disconnected from the pump by removing the four socket head cap screws which attach it to the center block. The piston should move freely and the ports in the piston should line up with the ports on the face of the air valve body (see *Figure D*). The piston should also appear to be dull, dark gray in color. If the piston appears to be a shiny aluminum color, the air valve is probably worn beyond working tolerances and should be replaced.

If the piston does not move freely in the air valve, the entire air valve should be immersed in a cleaning solution.

**NOTE:** Do not force the piston by inserting a metal object.

This soaking should remove any accumulation of sludge and grit which is preventing the air valve piston from moving freely. Also, remove and clean the air valve screen (P/N 04-2500-03).

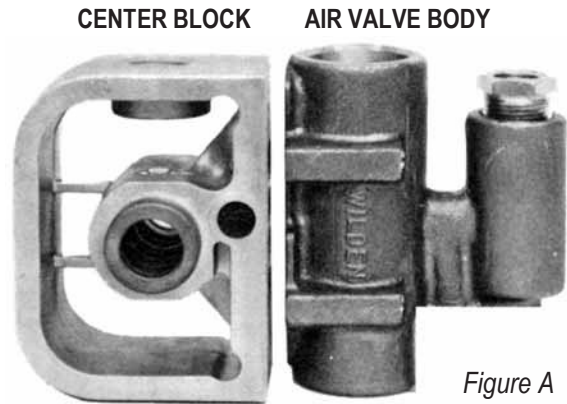
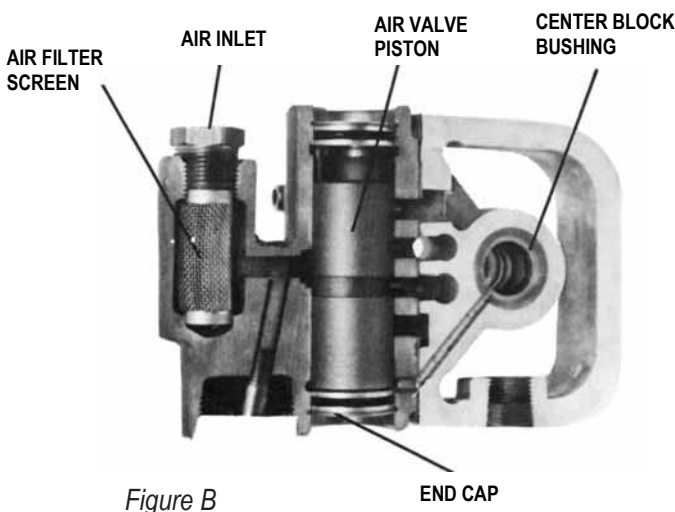

*Figure A*

#### AIR VALVE ASSEMBLY

If the air valve piston does not move freely after the above cleaning, the air valve should be disassembled as follows: Remove the snap ring from the top end of the air valve cylinder and apply an air jet to the 3/16-inch hole on the opposite end of the air valve face (see *Figure C*).

**CAUTION:** The air valve end cap may come out with considerable force. Inspect the piston and cylinder bore for nicks and scoring.



*Figure B*

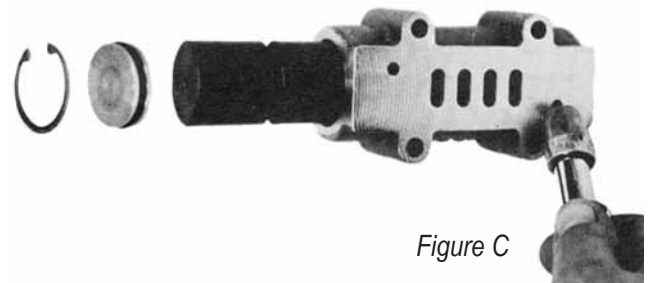

*Figure C*

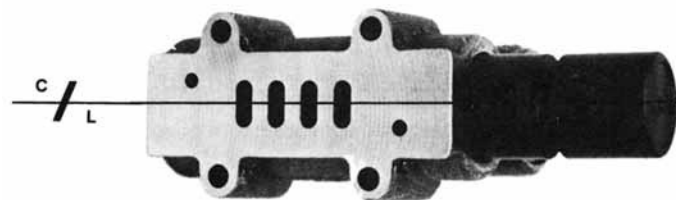

*Figure D*

## Disassembly / Reassembly

The air valve assembly consists of both the air valve body and piston and the center block. The unique design of the air valve relies only on differential pressure to effect the diaphragm shift. It is reliable and simple to maintain. The bushing in the center block, along with the diaphragm shaft, provides the “trigger” to tell the air valve to shift. The following procedure will ensure that the air valve on your Wilden pump will provide long trouble-free service.

### GLYD™ RING REPLACEMENT:

When the Glyd™ rings become worn, they will no longer seal and must be replaced. Due to the design characteristics of the Glyd™ rings, it is suggested that you use the Ringer Seal installation kit when replacing Glyd™ rings. Consult EOM- Ringer for installation instructions.

### CENTER BLOCK ASSEMBLY (P/N 04-3100-01-225):

The pump's center block (P/N 04-3100-01-225) consists of a die cast housing with a cast-in-bronze bushing (Figure G). Figure H shows T4 injection-molded polypropylene center section (P/N 04-3150-20) and alignment with air valve. The bushing has eleven grooves cut on the inside diameter. There are seven Glyd™ rings that fit in these grooves (see Figure E). Since these Glyd™ rings form a part of the shifting function of the pump, it is necessary that they be located in the proper grooves. The bronze bushing is replaceable in cast iron center block must be used.

This soaking should remove any accumulation of sludge and grit which is preventing the air valve piston from moving freely. Also, remove and clean the air valve screen (P/N 04- 2500-03).



Figure F  
(Side View)

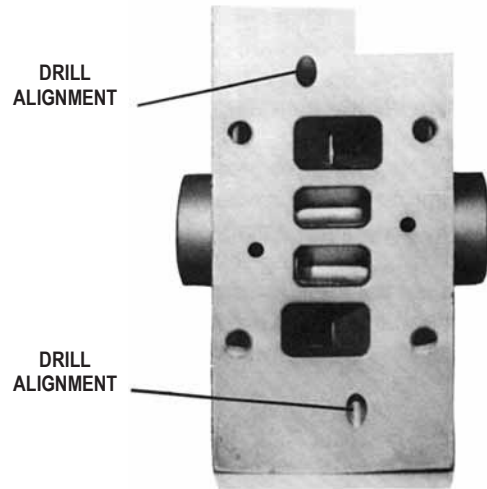
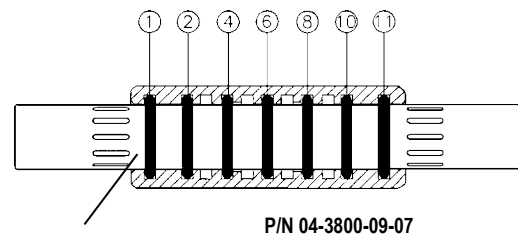

Figure G  
Center Block  
(Front View)

### Grooves In Bushing Which Contain Glyd™ Rings



P/N 04-3100-01-225

Figure E

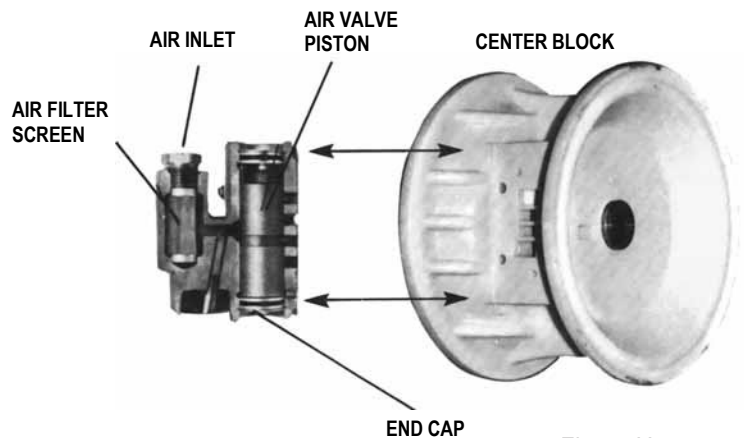

Figure H

\*Refer to Section 8 for torque specifications.

## Disassembly / Reassembly

### REASSEMBLY HINTS & TIPS

#### REASSEMBLY

Upon performing applicable maintenance to the air distribution system, the pump can now be reassembled. Please refer to the disassembly instructions for photos and parts placement. To reassemble the pump, follow the disassembly instructions in reverse order. The air distribution system needs to be assembled first, then the diaphragms and finally the wetted path. Please find the applicable torque specifications on this page. The following tips will assist in the assembly process.

- Clean the inside of the center section shaft bushing to ensure no damage is done to new seals.
- Stainless bolts should be lubed to reduce the possibility of seizing during tightening.
- Be sure to tighten outer pistons simultaneously on PTFE-fitted pumps to ensure proper torque values.

#### MAXIMUM TORQUE SPECIFICATIONS

Description of Part	Metal Pumps
Air Valve	3.4 N·m [30 in-lbs]
Outer Piston	54.2 N·m [40 ft-lbs]
Small Clamp Band	3.4 N·m [30 in-lbs]
Large Clamp Band (Rubber-Fitted)	10.7 N·m [95 in-lbs]
Large Clamp Band (PTFE-Fitted)	13.5 N·m [120 in-lbs]
Center Block Assembly	8.5 N·m [75 in-lbs]
Polyurethane Screen Base	2.3 N·m [20 in-lbs]

## Gasket Kit / Installation

The Wilden T4 cast iron pumps require PTFE gasket tape on the liquid chambers (P/N 04-9502-99). Other pump types may use PTFE gasket kits for additional sealing characteristics. During reassembly follow the procedures listed in your pump's Engineering, Operation and Maintenance manual.

Carefully prepare sealing surfaces by removing all debris and foreign matter from diaphragm bead and all mating surfaces. If necessary, smooth or deburr all sealing surfaces. Mating surfaces must be properly aligned in order to ensure positive sealing characteristics.

**Always wear safety glasses when performing maintenance on any Wilden product.**

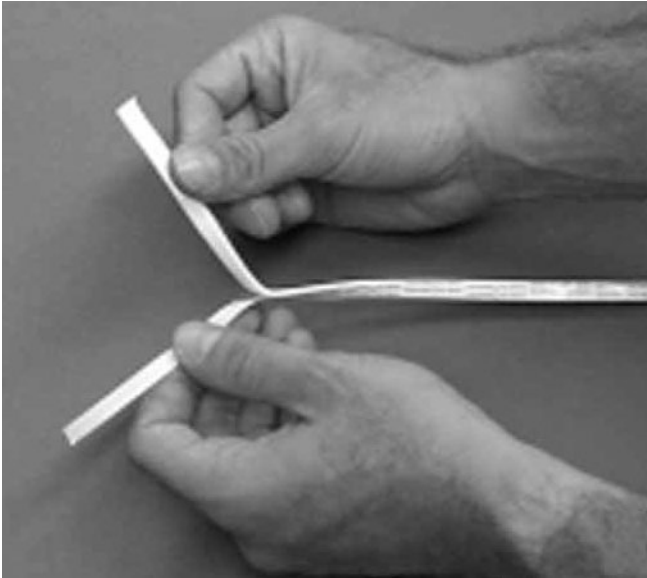

### Step 1

Gently remove the adhesive covering from the back of the PTFE tape. Ensure that the adhesive strip remains attached to the PTFE tape.



### Step 2

Starting at any point, place the PTFE tape in the center of the diaphragm bead groove on the liquid chamber and press lightly on the tape to ensure that the adhesive holds in place during assembly. Do not stretch the tape during placement in the center of diaphragm bead groove.



### Step 3

The end of the tape should overlap approximately 13 mm (1/2"). Proceed to install the PTFE tape on the remaining diaphragm.

**T4 METAL**

**EXPLODED VIEW**

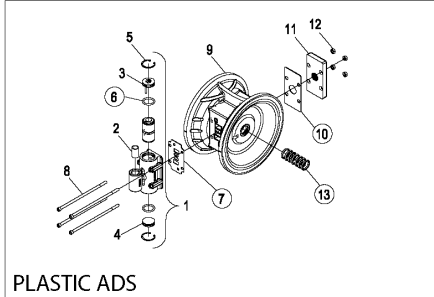
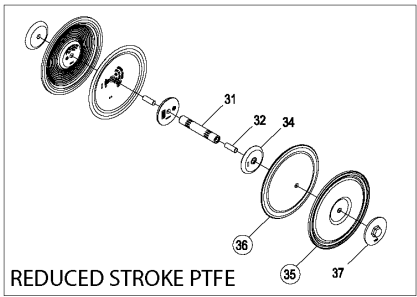
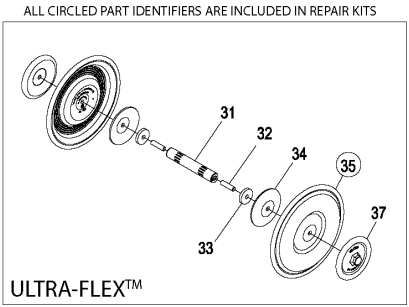
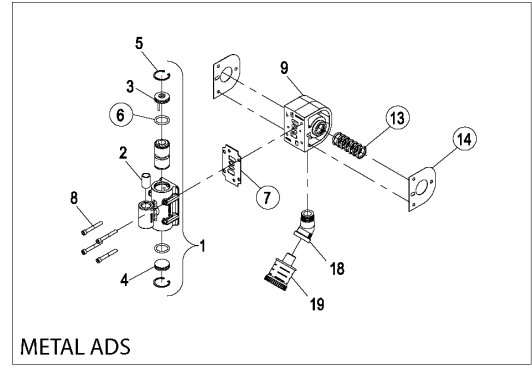
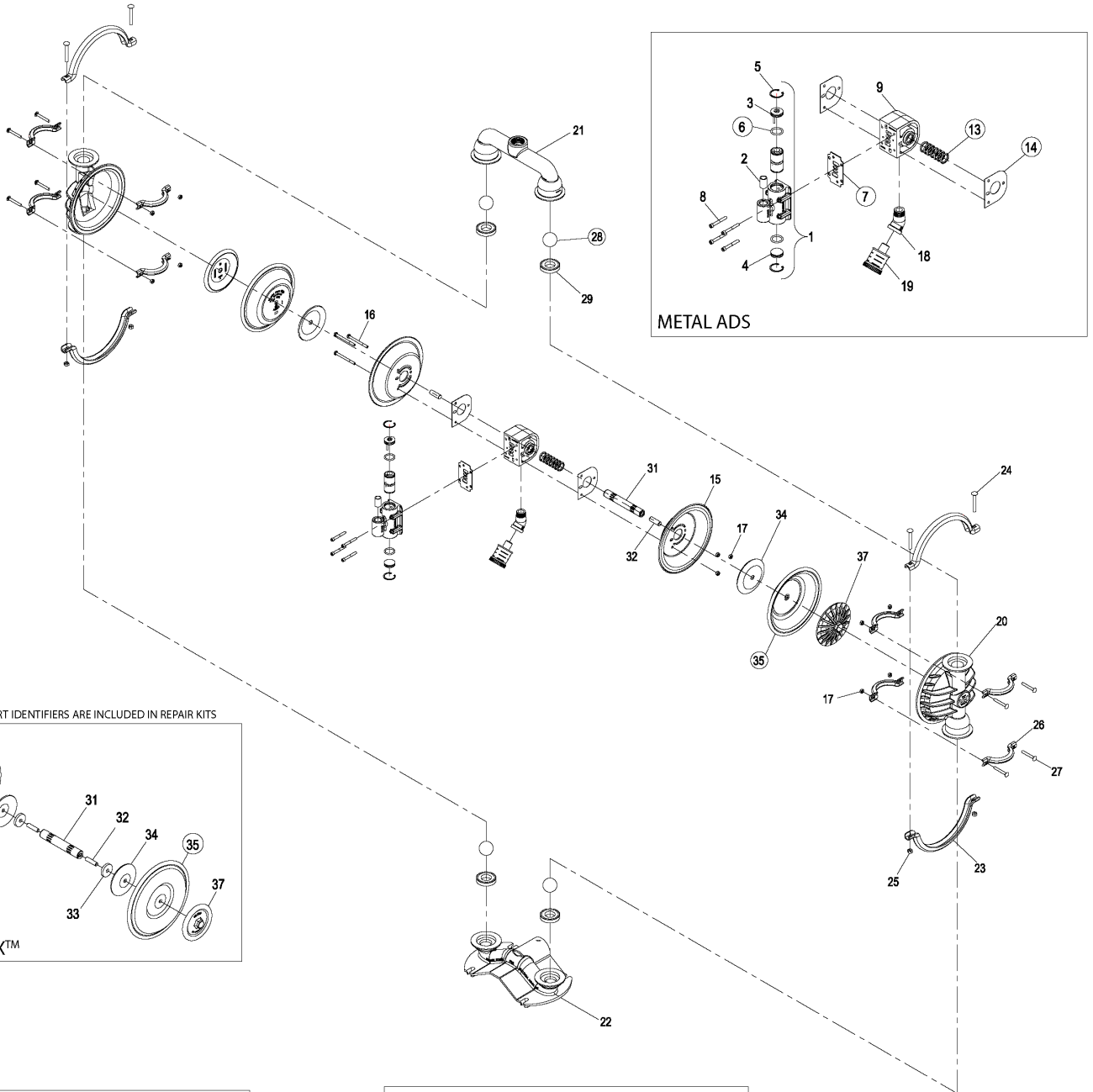

# Exploded View and Parts List

			Model Description			
			T4/AAMAB <sup>4</sup>	T4/AAPPB <sup>4</sup>	T4/WWPPB <sup>4</sup>	T4/WWMAB <sup>4</sup>
Item	Description	Qty.	P/N	P/N	P/N	P/N
<b>Air Distribution Components</b>						
1	<b>Air Valve Assembly<sup>1</sup></b>	1			04-2000-07	
2	Air Valve Screen	1			04-2500-07	
3	End Cap w/Guide (Top)	1			04-2300-23	
4	End Cap w/o Guide (Bottom)	1			04-2330-23	
5	Snap Ring	2			04-2650-03	
6	<b>Air Valve End Cap O-Ring (-214, Ø.984" x Ø.139")</b>	2			04-2390-52	
7	<b>Gasket, Air Valve</b>	1			04-2600-52	
8	Screw, SHC, Air Valve (1/4"-20 x 2")	4	04-6000-08			04-6000-08
	Screw, SHC, Air Valve (1/4"-20 x 6-11/16")	4			04-6000-03-500	
9	Center Block Assembly <sup>2</sup>	1	04-3100-01-225			04-3100-01-225
	Center Section Assembly <sup>3</sup>	1			04-3150-20-225	
10	<b>Gasket, Muffler Plate</b>	1			04-3500-52	
11	Muffler Plate	1			04-3180-20	
12	Hex Nut, Air Valve (1/4"-20)	4			04-6400-03	
13	<b>Seal, Shaft, Glyd Ring</b>	7			08-3210-55-225	
14	<b>Gasket, Center Block</b>	2	04-3520-52			04-3520-52
15	Air Chamber	2	04-3650-08			04-3650-08
16	Screw, HHC, (1/4"-20 X 3")	3	04-6130-08			04-6130-08
17	Nut, Hex (1/4"-20)	11	04-6400-08			04-6400-08
	Nut, Hex (1/4"-20)	8			04-6400-08	
18	Connector, Muffler (3/4" x 45°)	1	08-3250-08			08-3250-08
19	Muffler, 3/4" MNPT	1			04-3510-99	
<b>Wetted Path Components</b>						
20	Liquid Chamber	2	04-5000-01			04-5000-02
21	Manifold, Discharge NPT	1	04-5020-01			04-5020-02
	Manifold, Discharge BSPT	1	04-5020-01-14			04-5020-02-14
22	Manifold, Inlet NPT	1	04-5080-01			04-5080-02
	Manifold, Inlet BSPT	1	04-5080-01-14			04-5080-02-14
23	Large Clamp Band Assembly <sup>5</sup>	2	04-7300-08		04-7330-08	04-7300-08
24	Carriage Bolt, Large Clamp Band (5/16"-18 x 2-1/2")	4			04-6070-08	
25	Hex Nut, Large Clamp Band (5/16"-18)	4			04-6420-08	
26	Small Clamp Band Assembly <sup>6</sup>	8			04-7100-08	
27	Carriage Bolt, Small Clamp Band (1/4"-20 x 2")	8			04-6050-08	
<b>Valve Balls/Valve Seats/Valve O-Rings</b>						
28	<b>Ball, Valve</b>	4			*	
29	<b>Seat, Valve</b>	4			*	
30	<b>Valve Seat O-Ring, PTFE Fitted (-226, Ø.198" x Ø.139") (not shown)</b>	4			04-1200-55	
<b>Rubber/TPE Components</b>						
31	Shaft, Non PTFE Fitted	1			04-3800-03-07	
32	Shaft Stud, 1/2"-20 X 1-7/8"	2	08-6150-08			
34	Piston, Inner	2			04-3700-08	
35	<b>Diaphragm, Primary</b>	2			*	
37	Piston, Outer	2	04-4552-01			04-4550-08
38	Screw, HHC, (1/2"-20 X 1") (not shown)	2				04-6090-08
<b>PTFE Components</b>						
31	Shaft, PTFE Fitted	1			04-3820-03-07	
32	Shaft Stud, 1/2"-20 X 1-7/8"	2			08-6150-08	
34	Piston, Inner	2			04-3752-01	
35	<b>Diaphragm, Primary</b>	2			*	
36	<b>Diaphragm, Back-Up</b>	2			*	
37	Piston, Outer	2	04-4600-01			04-4600-03
<b>Ultra-Flex™ Components</b>						
31	Shaft, Ultra-Flex™ Fitted	1			04-3830-03-07	
32	Shaft Stud, 3/8"-16 X 1-1/2"	2				04-6152-08
33	Spacer, Piston, Ultra-Flex™	2			04-3860-08	
34	Piston, Inner, Ultra-Flex™	2			04-3760-08	
35	<b>Diaphragm, Primary</b>	2			*	
37	Piston, Outer	2	04-4560-01			04-4560-02

LW0523 Rev. A

\* See elastomer chart - Section 9

<sup>1</sup> Air Valve Assembly includes items 2, 3, 4, 5 and 6.

<sup>2</sup> Metal Center Block Assembly includes item 13.

<sup>3</sup> Plastic Center Block Assembly includes item 13.

<sup>4</sup> Pumps with PTFE Diaphragms contains Stainless Steel Hardware.

<sup>5</sup> Large Clamp Band Assembly includes item 24 and 25.

<sup>6</sup> Small Clamp Band Assembly Includes item 17 and 27.

**All boldface items are primary wear parts.**

**Section 9**

**Elastomer Options**

**T4 Metal Pumps**

Material	Diaphragm (2)	Back-Up Diaphragms (2)	Ultra-Flex™ Diaphragms (2)	Valve Balls (4)	Valve Seats (4)	Valve Seat* O-Rings (4)
Polyurethane	04-1010-50			04-1080-50	04-1120-50	
Neoprene	04-1010-51	04-1060-51	04-1020-51	04-1080-51	04-1120-51	
Buna-N®	04-1010-52		04-1020-52	04-1080-52	04-1120-52	
EPDM	04-1010-54	04-1060-54	04-1020-54	04-1080-54	04-1120-54	
FKM	04-1010-53		04-1020-53	04-1080-53	04-1120-53	
PTFE <sup>2</sup>	04-1010-55			04-1080-55		04-1200-55 <sup>1</sup>
Saniflex™ <sup>2</sup>	04-1010-56	04-1060-56		04-1080-56	04-1120-56	
Wil-Flex™	04-1010-58			04-1080-58	04-1120-58	
Aluminum					04-1121-01	
Stainless Steel					04-1121-03	
Mild Steel					04-1121-08	

<sup>1</sup> Used in conjunction with metallic valve seat.

LW0523 Rev. A

**T4 Metal STALLION Pumps**

Material	Diaphragms (2) P/N	Valve Balls (4) P/N	Valve Seats (4) P/N
Neoprene	04-1020-51	04-1080-51-50	04-1120-51-50
Buna-N	04-1020-52	04-1080-52-50	04-1120-52-50
EPDM	04-1020-54	04-1080-54-50	04-1120-54-50
FKM®	04-1020-53	04-1080-53-50	04-1120-53-50

PSG  
22069 Van Buren Street  
Grand Terrace, CA 92313-5651 USA  
P: +1 (909) 422-1730 • F: +1 (909) 783-3440  
psgdover.com



Where Innovation Flows