

Brand Portfolio

simple. reliable. efficient.



WILDEN®

Where Innovation Flows



From Innovator to Market Leader



Since 1955, Wilden® has been the global leader in air-operated double-diaphragm (AODD) pump technology. As the inventor of the AODD pump, Wilden introduces a constant flow of new innovations that have catapulted the positive displacement pump into the future. From developing premier AODD pump technology to offering the world's largest selection of diaphragms, Wilden's extensive knowledge base combined with unprecedented new technologies and unparalleled customer service provides end users with the peace of mind they need when selecting a process-solution provider.

Wilden resides in Grand Terrace, CA, where the facility occupies more than 170,000 square feet (15,793 square meters), incorporating a world-class lean manufacturing facility. Committed to excellence, innovation and developing the most trustworthy AODD-pump technology in the industry, Wilden operates a fully equipped R&D laboratory, clean room, test facility, QC department, CAD department, injection-molding center and customer satisfaction department at the site.

Serving the energy, process, hygienic, mining and water and wastewater markets, Wilden's world-class distributor network ensures that you will have access to the latest pump technologies and fluid transfer services available when you need them. To find a distributor closest to you, visit wildendistributor.com.



ENERGY



PROCESS



HYGIENIC



MINING



WATER/WASTEWATER

Working Principle of Wilden AODD Pumps

Wilden AODD pumps are reciprocating, positive-displacement-style pumps driven by compressed air. The following drawings and information detail the liquid flow pattern through the pump from its initial unprimed position.

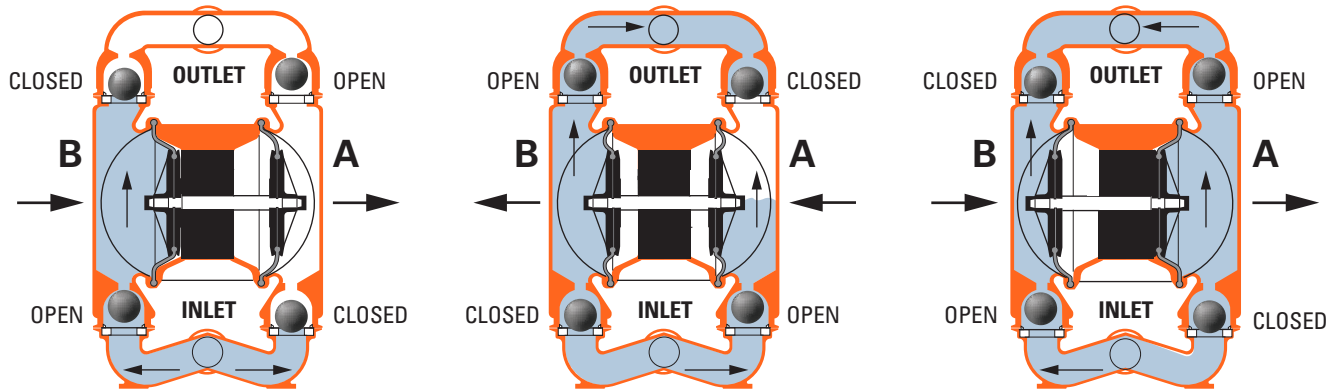

1. The air valve directs pressurized air to the back side of Diaphragm A.
2. The compressed air moves the diaphragm away from the center of the pump.
3. Diaphragm B is pulled in by the shaft connected to the pressurized Diaphragm A.
4. Diaphragm B is now on its suction stroke. The movement of Diaphragm B toward the center of the pump creates a vacuum within chamber B and causes the atmospheric pressure to force fluid into the inlet manifold forcing the inlet valve ball off its seat.
5. When the pressurized diaphragm, Diaphragm A, reaches the limit of its discharge stroke, the air valve redirects pressurized air to the back side of Diaphragm B.
6. The pressurized air forces diaphragm B away from the center while pulling Diaphragm A to the center.
7. Diaphragm B is now on its discharge stroke. Diaphragm B forces the inlet valve ball onto its seat due to the hydraulic forces.
8. The hydraulic forces lift the discharge valve ball off its seat, while the opposite discharge valve ball is forced onto its seat, forcing fluid to flow through the pump discharge.
9. At completion of the stroke, the air valve redirects air to the back side of diaphragm A, which starts diaphragm B on its exhaust stroke.
10. As the pump reaches its original starting point, each diaphragm has gone through one exhaust and one discharge stroke.

This constitutes one complete pumping cycle. The pump may take several cycles to completely prime depending on the conditions of the application.

Benefits of AODD Pumps

Thanks to their unique operating principle, AODD pumps excel in a wide variety of applications and incorporate numerous features and benefits, including:

- Self priming
- Portable
- High vacuum
- Lube-free operation
- No mechanical seals - reduces risk of leaks
- Run-dry capable
- No heat generation
- Submersible
- Superior product containment
- Easy installation
- Corrosion resistant
- Longest Mean Time Between Failure (MTBF)
- Anti-freezing



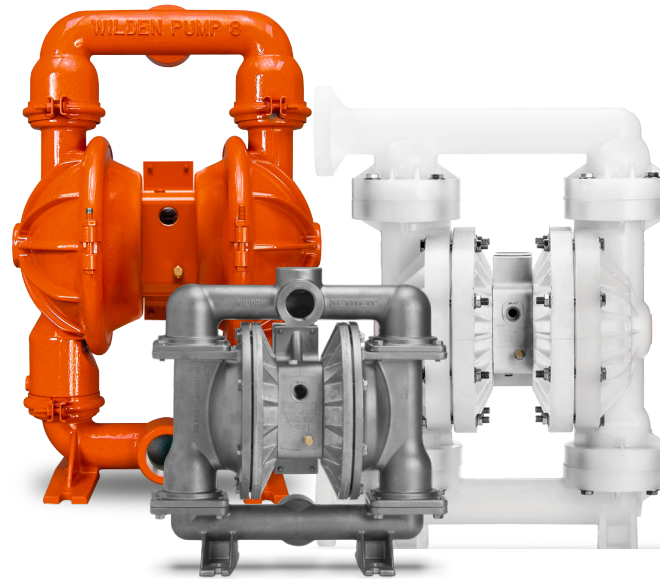
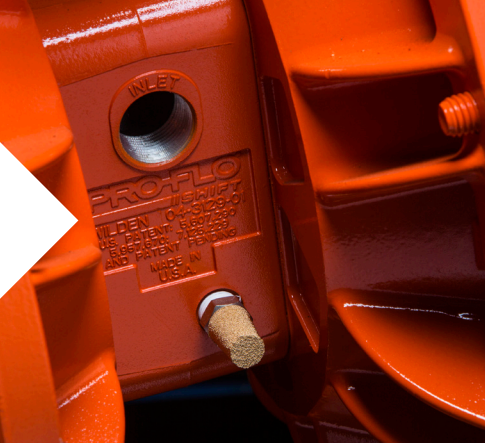

Wilden Pro-Flo® SHIFT Series

The Wilden Pro-Flo® SHIFT Series is the premier AODD pump. The innovative, yet simple, Pro-Flo SHIFT design features an air control spool that automatically optimizes air consumption and eliminates the overfilling that can lead to overcharging of the air chamber, all while causing no corresponding reduction in flow rate. This results in a reduction of air consumption and operational costs while maximum operational efficiency and volumetric consistency are maintained. Pro-Flo SHIFT Pumps are an exact fit from bolt-down footprint to inlet/discharge connections and can drop into existing fluid-handling piping systems.

- Delivers more yield per SCFM versus competitive AODD pumps
- Longer diaphragm life
- ATEX-compatible for use in explosive atmospheres
- Ability to use wet/dry air
- Fewer operating parts, meaning less downtime and simplified maintenance
- Quiet operation

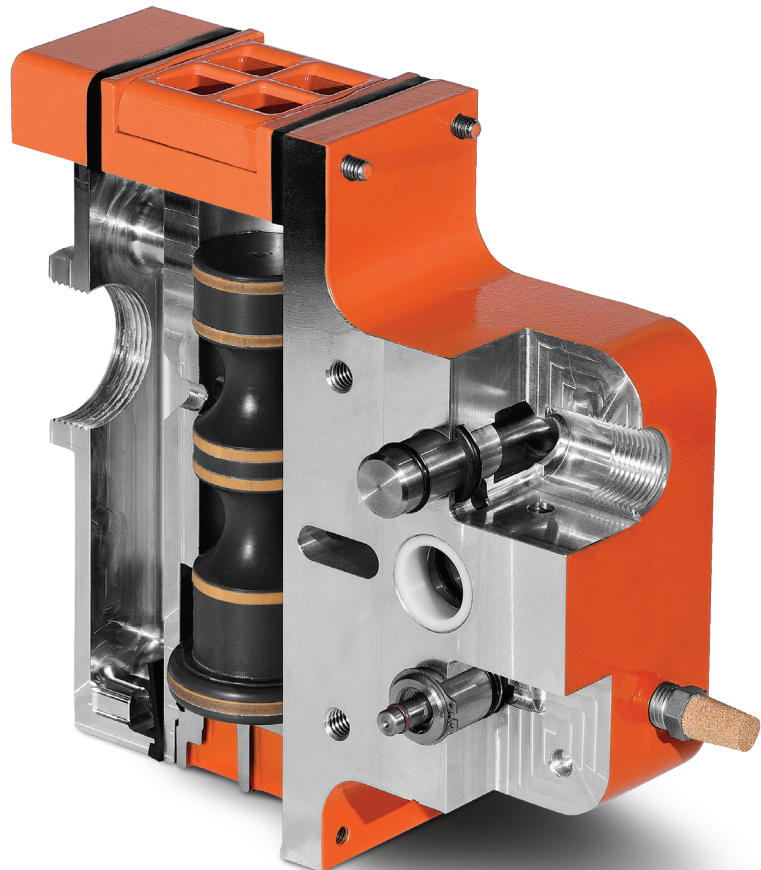
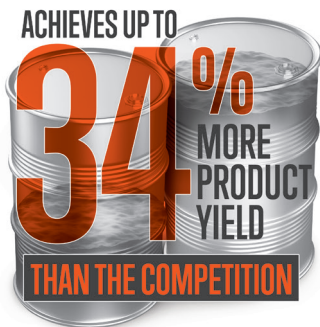

Pro-Flo SHIFT Series Technical Specifications



Metal	Size	Connection Type	Wetted Path Material	Max. Flow Rate	Max. Suction Lift	Max. Solids Passage	Certifications
	13 mm (1/2")	Clamped	Alloy C, Aluminum, Stainless Steel	60.2 lpm (15.9 gpm)	5.9 m Dry (19.3') 9.8 m Wet (32.3')	1.6 mm (1/16")	EX CE
	25 mm (1")	Bolted	Alloy C, Aluminum, Ductile Iron, Stainless Steel	212 lpm (56 gpm)	6.9 m Dry (22.7') 9.0 m Wet (29.5')	6.4 mm (1/4")	EX CE
	38 mm (1-1/2")	Bolted	Alloy C, Aluminum, Ductile Iron, Stainless Steel	510 lpm (135 gpm)	6.2 m Dry (20.4') 9.3 m Wet (30.6')	6.4 mm (1/4")	EX CE
		Clamped	Aluminum, Ductile Iron, Stainless Steel	375 lpm (99 gpm)	7.1 m Dry (23.3') 8.6 m Wet (28.4')	4.8 mm (3/16")	EX CE
	51 mm (2")	Bolted	Alloy C, Aluminum, Ductile Iron, Stainless Steel	685 lpm (181 gpm)	7.1 m Dry (23.3') 9.0 m Wet (29.5')	6.4 mm (1/4")	EX CE
		Clamped	Aluminum, Cast Iron, Stainless Steel	723 lpm (191 gpm)	7.2 m Dry (23.8') 9.0 m Wet (29.5')	6.4 mm (1/4")	EX CE
	76 mm (3")	Bolted	Alloy C, Aluminum, Ductile Iron, Stainless Steel	1,026 lpm (271 gpm)	7.2 m Dry (23.8') AL 9.7 m Wet (31.8') Iron	12.7 mm (1/2")	EX CE
		Clamped	Aluminum, Ductile Iron, Stainless Steel	927 lpm (245 gpm)	6.6 m Dry (21.6') 8.6 m Wet (28.4')	9.5 mm (3/8")	EX CE
102 mm (4")	Clamped	Cast Iron	1,048 lpm (277 gpm)	4.4 m Dry (14.4') 8.6 m Wet (28.4')	35 mm (1-3/8")	EX CE	



Plastic	Size	Connection Type	Wetted Path Material	Max. Flow Rate	Max. Suction Lift	Max. Solids Passage	Certifications
	6 mm (1/4")	Bolted	Polypropylene, PVDF, Conductive Polypropylene, Conductive PVDF	21.6 lpm (5.7 gpm)	4.2 m Dry (14') 8.5 m Wet (28')	1.6 mm (1/16")	EX CE
	38 mm (1-1/2")	Bolted	Polypropylene, PVDF, Conductive Polypropylene, Conductive PVDF	458 lpm (121 gpm)	5.6 m Dry (18.4') 9.0 m Wet (29.5')	6.4 mm (1/4")	EX CE
		Clamped	Polypropylene, PVDF	379 lpm (100 gpm)	6.2 m Dry (20.4') 8.3 m Wet (27.2')	4.8 mm (3/16")	CE
	51 mm (2")	Bolted	Polypropylene, PVDF, Conductive Polypropylene, Conductive PVDF	709 lpm (187 gpm)	5.9 m Dry (19.3') 8.3 m Wet (27.2')	6.4 mm (1/4")	EX CE
		Clamped	Polypropylene	643 lpm (170 gpm)	6.6 m Dry (21.8') 8.3 m Wet (27.2')	6.4 mm (1/4")	CE
	76 mm (3")	Bolted	Polypropylene, PVDF	1,024 lpm (271 gpm)	5.8 m Dry (19.1') 8.6 m Wet (28.4')	12.7 mm (1/2")	CE

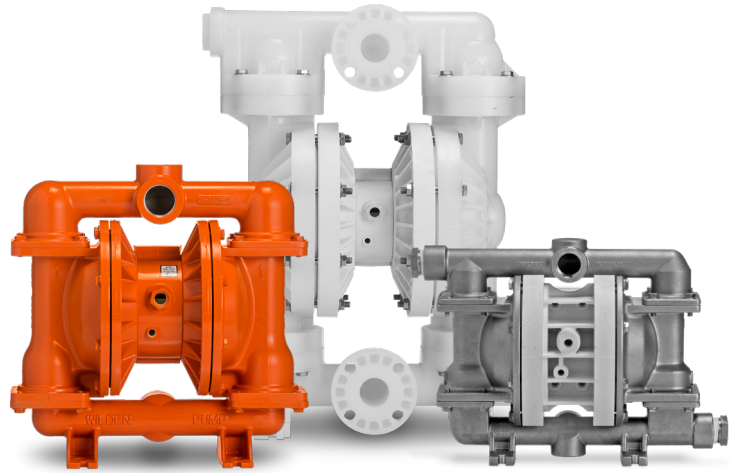
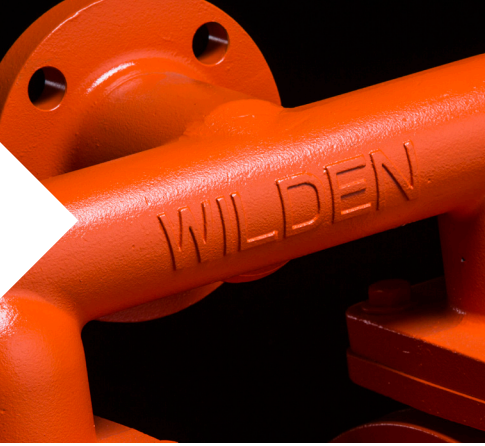

Wilden Pro-Flo® Series

As the industry's workhorse, the Wilden Pro-Flo® Series combines elegant simplicity with robust and reliable performance that end users have come to depend on for more than 20 years. Ideally suited for industrial applications calling for a durable chemical pump or oil pump, Pro-Flo Series pumps utilize advanced technology to increase productivity, reduce energy consumption, reduce air consumption and reduce maintenance. The Pro-Flo Series gives you extreme flexibility and reliability – with a wide range of sizes and material offerings – that end users can count on to deliver the consistent performance promised for challenging applications.

- Maximum reliability
- Longest lasting wear parts
- Lube-free operation
- Anti-freezing
- Non-stalling unbalanced spool
- Simple and durable design

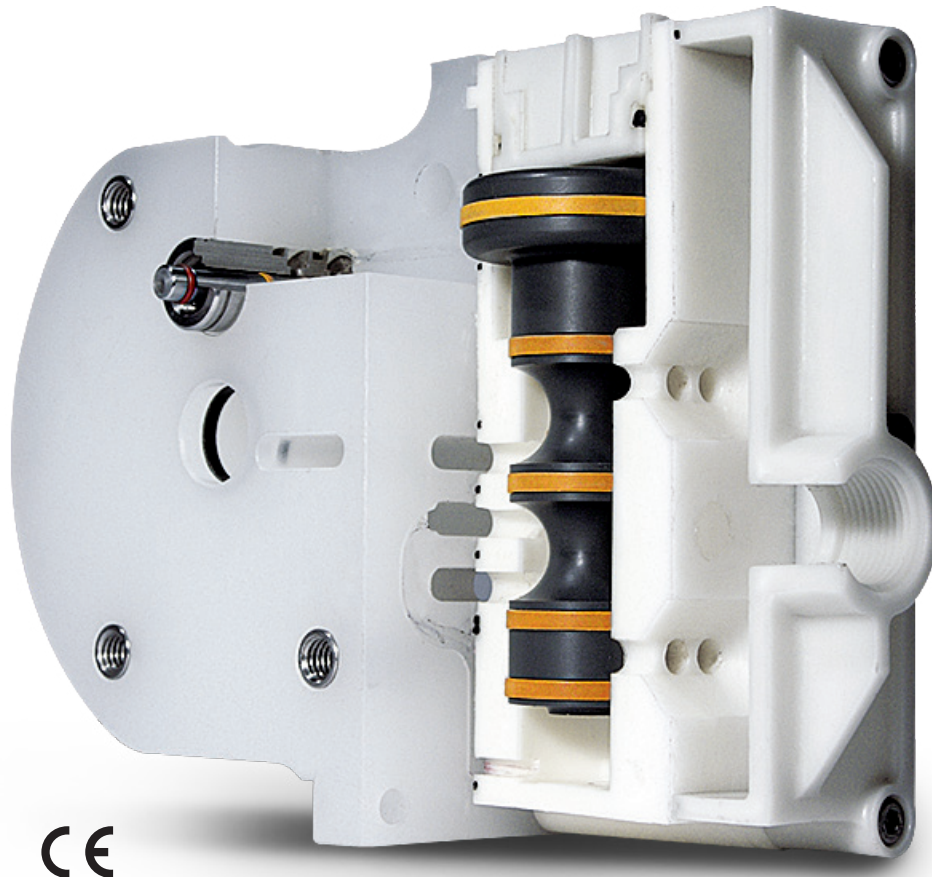

CE

Pro-Flo Series Technical Specifications



Metal	Size	Connection Type	Wetted Path Material	Max. Flow Rate	Max. Suction Lift	Max. Solids Passage	Certifications
	6 mm (1/4")	Clamped	Aluminum, Stainless Steel	18.9 lpm (5 gpm)	3.3 m Dry (10.8') 9.3 m Wet (30.6')	0.4 mm (1/64")	CE
	13 mm (1/2")	Clamped	Aluminum, Stainless Steel	58.7 lpm (15.5 gpm)	5.8 m Dry (19.0') 9.5 m Wet (31.0')	1.6 mm (1/16")	CE
	25 mm (1")	Bolted	Aluminum, Ductile Iron, Stainless Steel	212 lpm (56 gpm)	5.4 m Dry (17.6') 9.3 m Wet (30.6')	6.4 mm (1/4")	Ex CE
		Clamped	Aluminum, Stainless Steel	172 lpm (45.5 gpm)	7.6 m Dry (25.0') 9.0 m Wet (29.5')	3.2 mm (1/8")	CE
	38 mm (1-1/2")	Bolted	Aluminum, Ductile Iron, Stainless Steel	492 lpm (130 gpm)	5.5 m Dry (8.2') 9.0 m Wet (29.5')	6.4 mm (1/4")	Ex CE
		Clamped	Aluminum, Ductile Iron, Stainless Steel	330 lpm (87.2 gpm)	6.4 m Dry (21.0') 9.3 m Wet (30.6')	4.8 mm (3/16")	CE
	51 mm (2")	Bolted	Aluminum, Ductile Iron, Stainless Steel	609 lpm (161 gpm)	7.4 m Dry (24.3') 9.0 m Wet (29.5')	6.4 mm (1/4")	Ex CE
		Clamped	Aluminum, Ductile Iron, Stainless Steel	630 lpm (166 gpm)	6.9 m Dry (22.7') 9.5 m Wet (31.0')	6.4 mm (1/4")	CE

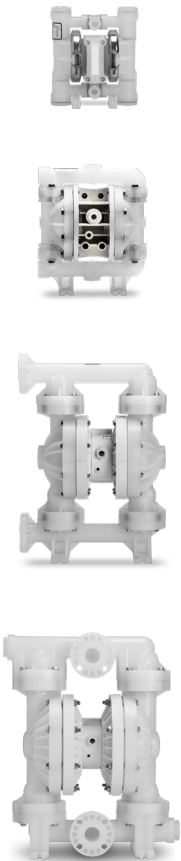

Plastic	Size	Connection Type	Wetted Path Material	Max. Flow Rate	Max. Suction Lift	Max. Solids Passage	Certifications
	6 mm (1/4")	Clamped	Polypropylene, PVDF	18.1 lpm (4.8 gpm)	3.05 m Dry (10.0') 8.84 m Wet (29.0')	0.4 mm (1/64")	CE
	13 mm (1/2")	Bolted	Polypropylene, PVDF, Conductive Polypropylene, Conductive PVDF	58.7 lpm (15.5 gpm)	5.5 m Dry (18.0') 9.3 m Wet (30.6')	1.6 mm (1/16")	Ex CE
		Clamped	Polypropylene, PVDF	56.8 lpm (15 gpm)	6.1 m Dry (20.0') 9.8 m Wet (32.0')	1.6 mm (1/16")	CE
	25 mm (1")	Bolted	Polypropylene, PVDF, Conductive Polypropylene, Conductive PVDF	220 lpm (58 gpm)	3.6 m Dry (11.9') 9.8 m Wet (32.0')	4.76 mm (3/16")	Ex CE
		Clamped	Polypropylene, PVDF	140 lpm (37 gpm)	5.5 m Dry (18.0') 8.8 m Wet (29.0')	3.2 mm (1/8")	CE
	38 mm (1-1/2")	Bolted	Polypropylene, PVDF	454 lpm (120 gpm)	5.7 m Dry (18.7') 9.3 m Wet (30.6')	6.4 mm (1/4")	CE
		Clamped	Polypropylene, PVDF	354 lpm (94 gpm)	4.88 m Dry (16.0') 9.3 m Wet (30.6')	4.8 mm (3/16")	CE
	51 mm (2")	Bolted	Polypropylene, PVDF	624 lpm (165 gpm)	6.23 m Dry (8.65') 9.0 m Wet (29.5')	6.4 mm (1/4")	CE
		Clamped	Polypropylene, PVDF	591 lpm (156 gpm)	7.4 m Dry (24.4') 9.45 m Wet (31.0')	6.4 mm (1/4")	CE
76 mm (3")	Bolted	Polypropylene, PVDF	878 lpm (232 gpm)	5.5 m Dry (18.2') 8.6 m Wet (28.4')	12.7 mm (1/2")	CE	

Specialty Series Pumps

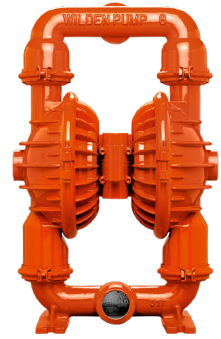
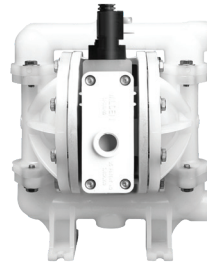
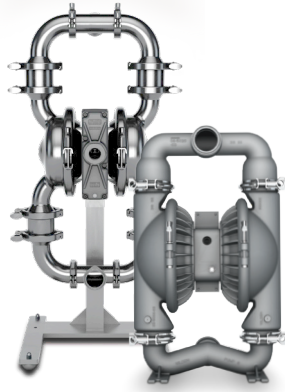

	Hygienic & Sanitary Saniflo™ HS, Saniflo FDA	Electronic Control Accu-Flo™	Utility Turbo-Flo™
Description	<p>Sanitary pump with flow-through design for efficiently pumping a wide range of viscosities, solids and shear-sensitive products.</p> <p>HS pumps feature quick disconnect clamps for clean-in-place (CIP) and clean-out-of-place (COP) capabilities.</p>	<p>Solenoid-controlled dosing pump for external control, precision metering and batching applications.</p> <p>Features direct electrical interface utilizing electrical impulses to stroke the pump providing variable stroke rate that can easily be control.</p> <p>Available as NEMA 5, NEMA 7 or ATEX-compliant and is available with a variety of voltage options.</p>	<p>Utility pump well suited for certain applications where quality of compressed air is a concern.</p> <p>Turbo-Flo pumps are easy-to-maintain, cost-effective and provide economical solutions for general and utilitarian applications.</p>
Applications	Food and beverage, pharmaceuticals/bio-pharm	Metering and batching	General transfer, de-watering, ceramic applications
Benefits	<ul style="list-style-type: none"> • Delicate product handling and shear sensitive • Large solids passage • CIP capabilities • Ease of maintenance • Minimized product degradation 	<ul style="list-style-type: none"> • Direct electrical interface • Superior ON/OFF reliability • Various voltage options • Externally controlled 	<ul style="list-style-type: none"> • Durable • Fewest replaceable parts • Ease of maintenance • Established air distribution system • Clamped construction for quick assembly and disassembly
Sizes Available	<p>Saniflo HS: 25 mm (1") - 76 mm (3")</p> <p>Saniflo FDA: 13 mm (1/2") - 76 mm (3")</p>	6 mm (1/4") - 25 mm (1")	38 mm (1-1/2") - 102 mm (4")
Max Flow Rate	<p>Saniflo HS: 844 lpm (223 gpm)</p> <p>Saniflo FDA: 927 lpm (245 gpm)</p>	170 lpm (45 gpm)	1041 lpm (275 gpm)
Certifications			
	<p>*Applies only to Saniflo HS</p> <p>**USP Class VI certification available only on Saniflo HS pumps with PTSE elastomer options</p>		

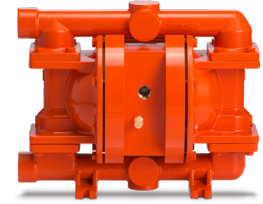
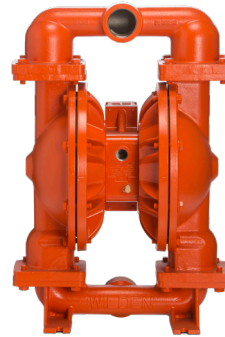
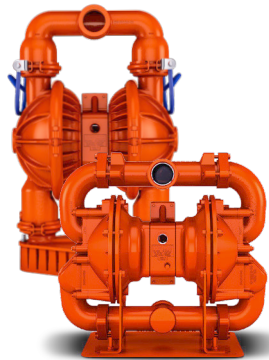
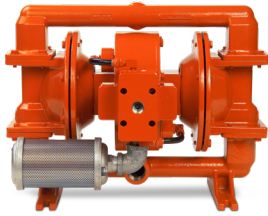



Wilden Diaphragms – The Right Solution For Every Application



As the inventors of AODD pump technology, Wilden offers the largest selection of AODD diaphragms in the world to ensure that your unique application is fully met with the best possible diaphragm. Wilden has a diaphragm for every industry and application, and Wilden's quality ensures superior construction and that each diaphragm is engineered with long flex life and superior durability.

Wilden diaphragms are available in a wide range of shapes, sizes and materials - including rubber, thermoplastic, PTFE and Wilden-developed Ultra-Flex™. Wilden also offers its patented Chem-Fuse™ and Pure-Fuse™ Integral Piston Diaphragms (IPDs) that eliminate potential leak points, offer easy cleanability and reduces abrasion for 2-3x longer diaphragm life.

Materials	Diaphragms							Traits		Chemical Resistance/Applications						Operating Temperature Limits	Cost
	IPD		Standard			Special Application		Flex Life	Abrasion Resistance	Ketones & Aldehydes	Acetates	Aromatic Hydrocarbons	Chlorinated Hydrocarbons	Oil & Gas	Water / Wastewater	(Max/Min)	(\$)
	Chem-Fuse™	Pure-Fuse™	EZ-Install	Traditional	Full-Stroke PTFE	Reduced-Stroke PTFE	Ultra-Flex										
Thermoplastic (TPE)	Wil-Flex®	✓	✓	✓*	✓*			A	A	✓	✓			✓	-50° to 130°C (-58° to 266°F)	\$	
	Saniflex™	✓	✓	✓	✓			B	A			✓			-29° to 104°C (-20° to 220°F)	\$\$	
	Bunlast™	✓		✓				A	A	✓	✓		✓	✓	-40° to 130°C (-40° to 266°F)	\$\$	
	Polyurethane			✓	✓			A	A					✓	-12° to 66°C (10° to 150° F)	\$	
PTFE	PTFE				✓	✓		A	B	✓	✓	✓	✓	✓	4° to 104°C (40° to 220°F)	\$\$\$	
Rubber	Buna-N				✓		✓	C	C					✓	-12° to 82°C (10° to 180°F)	\$\$	
	EPDM				✓		✓	B	C	✓	✓				-51° to 138°C (-60° to 280°F)	\$\$	
	Neoprene				✓		✓	B	C				✓		-18° to 93°C (0° to 200°F)	\$	
	FKM				✓		✓	C	C			✓	✓		-40° to 177°C (-40° to 350°F)	\$\$\$\$	

A = EXCELLENT B = GOOD C = FAIR

Note: *Wil-Flex® Traditional Diaphragm Operating Temperature Limits are: -40° to 107°C (-40° to 225°F)

Note: The above chemical resistance is intended as a guide. Consult your authorized Wilden distributor regarding which diaphragm material will work best for your application requirements.



Accessories

Wilden's accessory products add value to your liquid process and expand the application range of Wilden pumps by augmenting the performance and/or utility of the pump. Use only genuine Wilden accessories to keep your AODD pumps running at peak performance, meet warranty requirements and expand their operations and utility.

- **Equalizer® Surge Dampeners** - engineered to reduce fluid pressure and flow fluctuations that are inherent in AODD pumps, providing a smoother discharge flow. This function is critical in applications that need to minimize vibration and control pipe hammer which protects the piping system as well as downstream instrumentation
- **Wil-Gard™** - detects and notifies plant personnel when a diaphragm has ruptured to prevent further damage to pump
- **Pump Cycle Monitor (PCMI)** - counts pump cycles by sensing the presence of the air valve spool
- **Drum Pump Kit** - enables Wilden 6 mm (1/4") and 13 mm (1/2") pumps to adapt directly to drums for cost-effective, efficient liquid transfer

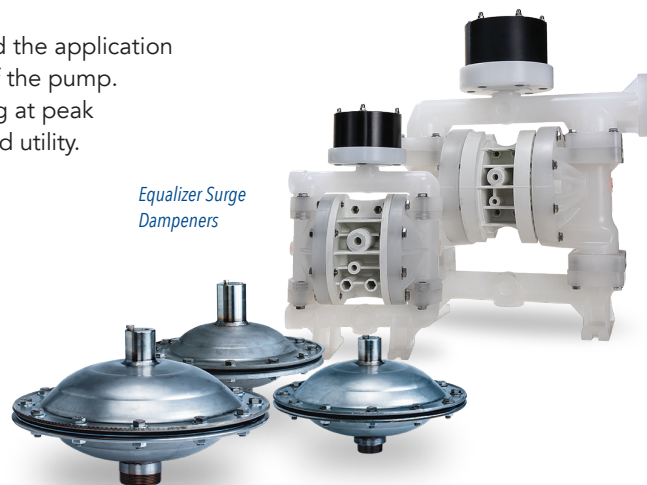

Equalizer Surge Dampeners

Wil-Gard



Pump Cycle Monitor



Drum Pump Kit



Repair Kits

Wilden wet and air repair kits for AODD pumps have been designed to help properly maintain the health and performance of your Wilden pump.

Always use only authentic Wilden Air Kits and Wet Kits when repairing or maintaining your Wilden products to preserve optimal performance and preserve factory warranties.

- Easily order online at your convenience
- Kits are maintained and shipped in sealed packaging
- Include all necessary components for repair

Wilden also offers retrofit kits which allow you to upgrade your existing pumps. Other spare parts outside of the traditional repair kits are available upon request.



WILDEN®

PSG
22069 Van Buren Street
Grand Terrace
CA, 92313-5651
USA
P: +1 (909) 422-1730
F: +1 (909) 783-3440
wildenpump.com



Where Innovation Flows

WIL-18040-C-19

Copyright 2026 PSG®, a Dover company

Authorized PSG® Partner: