

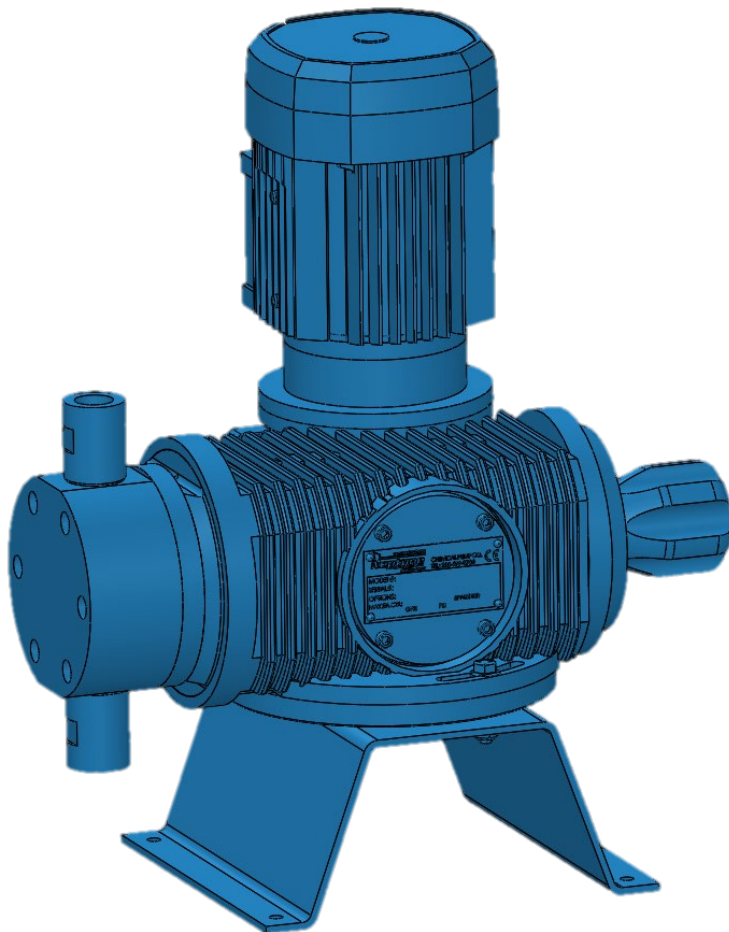

INSTALLATION OPERATION & MAINTENANCE



NEPTUNE

**Series 7000
Mechanical
“dia-PUMP”**

**Models
MP7007, MP7010,
MP7015**



NEP-ZL130009

PSG
22069 Van Buren Street
Grand Terrace, CA 92313 USA
P: +1 (215) 699-8700 F: +1 (215) 699-0370
neptune1.com

Copyright 2018 PSG®, a Dover Company

NEP-ZL130009
03.2018_REV 3



a **DOVER** company

psgdover.com

WARNING

LOCKOUTS ARE REQUIRED BEFORE
SERVICING THIS EQUIPMENT.

SAFETY INSTRUCTIONS:

Shut off/Lockout pump Power before Servicing.

Be certain pump isolation valves are
Closed and chemical is shut off.

Bleed pressure before servicing.

In case of emergency, shut pump down completely
by disconnecting motor power supply.

To prevent unexpected start-up, disconnect motor
from power supply when power outage happens.

WARNING

Please read thoroughly before installation, operation or maintenance of any Neptune pump

EQUIPMENT MISUSE HAZARD

Equipment misuse can cause the equipment to rupture, malfunction and result in serious injury.

- This equipment is for professional use only.
- Read all instruction manuals, tags and labels before operating the equipment.
- Use the equipment only for its intended use.
- Do not alter or modify this equipment.
- Be certain all operators of this equipment have been trained for safe working practices, understand its limitations and wear safety goggles and or equipment when required
- Do not exceed the maximum working pressure of the system as mentioned on the pump tag.
- Do not use the pump head or the suction or discharge piping to pull the equipment.
- Do not move pressurized pump.
- Use fluids or cleaning agents for cleaning that are compatible with the pump parts. Read the fluid and cleaning agent manufacturer's warning and also refer to the material compatibility chart.
- Comply with all applicable local, state and national safety regulations.
- Do not allow the pump to run dry for long periods.

PRESSURIZED EQUIPMENT HAZARD

Spray from leaks, ruptured components can splash fluid in eyes or on skin and cause serious injury.

Leaks from ruptured components • • • • •

- Shut off the pump and depressurize before performing any maintenance.
- Do not tamper with or perform unspecified alteration of the device.
- Operate only at rated pressure. Excessive pressure during normal operation can cause leakage and rupture to the pump head joint and/or pipes. Rated pressure can be found on pump name tag.
- Use only pipes, hoses and hose fittings rated for maximum rated pressure of the pump or the pressure at which the pressure relief valve is set at.
- Always wear protective clothing, face shield, safety glasses and gloves when working on or near the metering pump.
- Additional precautions should be taken depending on the solution being pumped. Refer to SDS precautions from your solution supplier.
- Do not stop or deflect fluid leaks with your hands, body, gloves or rags.
- Tighten all fluid connections before operating the equipment.
- Replace worn damaged or loose parts immediately.
- Before performing any maintenance requiring pump head and or valve (wetting parts) disassembly, be sure to relieve pressure from the piping system and where hazardous process chemicals are present.
- Make the pump safe to handle for individuals and the environment by leaning and chemically neutralizing the pump when appropriate.
- Wear protective clothing and use proper tools as appropriate to avoid any injury.

FIRE AND EXPLOSION HAZARD

Improper grounding, poor air ventilation, open flames, or sparks can cause a hazardous condition and result in fire or explosion and serious injury.

- Ground the equipment. See motor installation instruction for grounding procedure.
- Do not pump non recommended flammable or explosive fluids.
- Static electricity may generate by fluid moving through pipes and hoses. A static spark could be produced by high fluid flow rates. Grounding of the pump is a must.
- Provide fresh air ventilation to avoid the possible buildup of flammable fumes from the process chemicals.
- Keep the pump area free of debris, including cleaning agent, rags, and any flammable material.
- Follow the cleaning agent and other cleaning recommendations as mentioned in the operation and instruction manuals.
- Use cleaning agent with the highest possible flash point to clean the pump parts if needed.
- If there is any static sparking while using the equipment, stop operation at once. Identify and correct the problem before starting up the pump.

TOXIC FLUID HAZARD

Hazardous fluids or toxic fumes can cause serious injury or death if splashed in eyes or on the skin, swallowed, or inhaled.

- Know the specific hazards of the fluid you are using. Read the fluid manufactures warnings.
- Consider chemical compatibility when selecting pump material. Reference Neptune chemical resistance guide in: <https://www.psgdover.com/neptune/download-library/guides> or contact Neptune Sales for recommendation.
- Store hazardous fluid in an approved container. Dispose of hazardous fluid according to all local, state and national guidelines.
- Wear the appropriate protective clothing, gloves, eyewear and respirator.
- Pipe and dispose of the exhaust air safely. If diaphragm fails, the fluid may be exhausted along with the air in mechanical diaphragm pump.

SOUND HAZARD

The sound pressure level of the pump may exceed 80dBA in some pumps.

- Observe all safety precautions when operating the pump within close proximity for extended periods by wearing hearing protectors.
- Extended exposure to elevated sound levels will result in permanent loss of hearing acuteness, tinnitus, tiredness, stress, and other effects such as loss of balance and awareness.

MECHANICAL HAZARD

The pump may shake or vibrate during operation.

- Vibration could occur due to loose mechanical component and foundation bolts, causing piping rupture and leakage of chemical to cause bodily injury. The pump should be bolted down to the base during operation.
- Pump may overturn when being transported if the motor is too heavy. Secure the pump on its base before transportation.

SECTION	PARAGRAPH	TABLE OF CONTENTS	PAGE
I		GENERAL DESCRIPTION	5
		LIMITED WARRANTY	6
		PARTS ORDERING INSTRUCTIONS	7
II		INSTALLATION INSTRUCTIONS	
	1	GENERAL	8
	2	SUCTION PIPING	9
	3	DISCHARGE PIPING	10
	4	INSTALLATION OUTDOORS	10
	5	STARTUP PROCEDURE	10
III		NORMAL MAINTENANCE	
	6	MAINTENANCE	11
		PARTS LIST	17
		COMMON PARTS LIST	17
		GEAR BOX PARTS LIST PER MODEL	18-20
IV	7	MOTOR OPERATING CONDITIONS	21
V		TROUBLE SHOOTING CHART	21
		DRAWINGS	
		MODEL MP7007-BN3 MECHANICALLY ACTUATED PUMP	13-16
		CROSS SECTION (HEAD AREA) MP7015-DN3, 5, 8	20
		SPARE PARTS KITS	22-23
		PUMP DATA / MAINTENANCE LOG	24

SECTION I

GENERAL DESCRIPTION

The Neptune MP7000 Mechanical Diaphragm metering pump is a reliable metering pump of the low-pressure diaphragm type. Under constant conditions of temperature, pressure, and capacity setting, a +/- 2% metered discharge volume is maintained. Rugged contoured composite diaphragm designed for high metering accuracy over a full 10:1 turndown range.

A reciprocating rod at a set stroke length and rate actuates a flexible, chemically inert, Teflon faced diaphragm creating the pumping action. Screwing in and out a hand knob regulates the capacity of the pump. Screwing in shortens the stroke length reducing the volume and screwing out increases capacity. A percentage of flow is read on the hand knob.

Precision-engineered liquid ends meters mild solutions, aggressive chemicals, high viscosity polymers (up to 200cP) and slurries (hydrated lime slurries up to 4 lb/gallon of water, activated carbon slurries up to 1 lb/gallon of water). If metering of liquids with higher viscosity is required please contact factory

Metering accuracy is maintained by the ball check valves in the suction and discharge pump heads. Screw-in cartridge ball check valves eases maintenance.

Temperature limitations on the plastic heads are: 36 – 125°F (2 - 52°C) for PVC; 36 - 200°F (2-93°C) for PVDF.

PLEASE READ INSTRUCTION MANUAL COMPLETELY BEFORE INSTALLING PUMP.

SECTION I

NEPTUNE CHEMICAL PUMP COMPANY LIMITED WARRANTY

All Neptune Pumps are tested at the factory prior to shipment. Each part used in their construction has been carefully checked for workmanship.

If the pump is installed properly, Neptune Chemical Pump Company warrants to the purchaser of this product for a period of thirty six (36) months from the date of shipment, this product shall be free of defects in material and/or workmanship, as follows:

- 1 Neptune Chemical Pump Company will replace, at no charge, any part that fails due to a defect in material and/or workmanship during the warranty period, FOB our factory, North Wales, Pennsylvania. To obtain warranty service, you must forward the defective parts to the factory for examination, freight pre-paid.¹
- 2 This warranty period does not cover any product or product part, which has been subject to accident, misuse, abuse or negligence. Neptune Chemical Pump Company shall only be liable under this warranty if the product is used in the manner intended by the manufacturer as specified in the written instructions furnished with this product. The warranty does not cover any parts clearly defined as consumables by Neptune Chemical Pump Company (such as, diaphragm, suction/discharge valves, oil seal, gaskets and sealing rings, elastomeric parts, etc.).
- 3 The accessories, optional components and other supporting devices (including motor) with nameplates are under the warranty of their OEM; the accessories, optional components and other supporting devices (including motor) with Neptune Chemical Pump Company nameplates or without any nameplates are under Neptune Chemical Pump Company warranty for a period of one (1) year.

Any express warranty not provided in this warranty document, and any remedy for breach of contract that, but for this provision, might arise by implication or operation of law, is hereby excluded and disclaimed. Under no circumstances shall Neptune Chemical Pump Company be liable to purchaser or any other person for any charge for labor, repairs, or parts, performed or furnished by others, nor for any incidental consequential damages, whether arising out of breach of warranty, express or implied, a breach of contract or otherwise. Except to the extent prohibited by applicable law, any implied warranty of merchantability and fitness for a particular purpose are expressly limited in duration to the duration of this limited warranty.

Some states do not allow the exclusion or limitation of incidental or consequential damages, or allow limitations on how long any implied warranty lasts, so the above limitations may not apply to you. This warranty gives you specific legal rights, and you may have other rights, which may vary from state to state.

IMPORTANT

SHOULD IT BE NECESSARY TO SEND THE PUMP TO THE FACTORY OR AN AUTHORIZED NEPTUNE REPAIR FACILITY FOR REPAIR OR MAINTENANCE REBUILDING; DRAIN ALL CHEMICAL FROM PUMP BEFORE SHIPPING. FAILURE TO DO SO CAN CAUSE EXTENSIVE DAMAGE TO THE MOTOR.

SEE IMPORTANT NOTICE –RETURN GOODS AUTHORIZATION

IMPORTANT NOTICE RETURN GOODS AUTHORIZATION

- (1) All equipment returned to Neptune Chemical Pump Company or a Neptune Authorized Repair Center Requires a Proper Returned Goods Authorization Number (RGA) and tags.
- (2) All equipment returned to the factory or a Neptune Authorized Repair Center for repair or service must first be thoroughly flushed and have all chemical contact areas neutralized.
- (3) All equipment which has been in contact with chemicals must be accompanied by a copy of the chemical product material Safety Data Sheet (SDS).
- (4) Failure to comply with the above instructions will result in equipment being returned to sender, freight collect, without service.

SECTION I

PARTS ORDERING INSTRUCTIONS

The complete model number and serial number of the pump must be furnished to insure prompt and accurate parts service. These numbers are found on the name plate (sample below) located on the back cover of the pump.

Please refer to page number (17), (18), (19), (20) for parts list. Ballooned drawing of the pumps can be found on pages (13), (14), (15), (16) and (20).

Spare Parts Kits are found on pages 22 and 23.

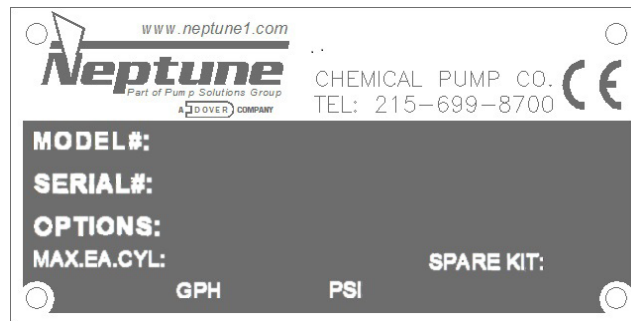

Send all orders or inquiries for parts to:

Email: order.neptune@psgdover.com

Website: www.psgdover.com/neptune.com

NOTE: PLEASE SUPPLY BOTH MODEL AND SERIAL NUMBERS.

SECTION II

INSTALLATION INSTRUCTIONS

1.0 GENERAL

1.0.1 UNPACKING & INSPECTION

When unpacking a pump or chemical feed system, be certain that no parts are thrown away. Examine the equipment for possible damage. If damage has occurred, file a claim with the common carrier within 24 hours. Neptune will assist in estimating the repair costs.

1.0.2 The Mechanically Actuated Diaphragm metering pumps should be located on a level surface. Four mounting holes are provided to anchor the pump base securely to the mounting surface. All piping to the pump should be supported to prevent stress on the pump inlet and discharge fittings.

1.0.3 Before connecting the pump make sure that all fittings are completely clean by flushing thoroughly. Foreign matter with sharp edges entering the pump can damage the diaphragm and severely limit the life of the pump.

1.0.4 A "Y" STRAINER (AT LEAST ONE PIPE SIZE LARGER THAN SUCTION PORT SIZE OF THE PUMP) MUST BE INSTALLED IN THE SUCTION LINE OF THE PUMP TO INSURE AGAINST FOREIGN MATTER ENTERING THE PUMP

1.0.5 It is recommended that isolation valves and unions be placed in the suction and discharge lines if possible. Such an arrangement will facilitate servicing the pump.

1.0.6 The electrical supply to the pump must match the motor nameplate characteristics. The motor rotation is counterclockwise when viewed from the top of the motor or looking down on the pump.

1.0.7 Do not fill pump with oil. Pump is designed with oil free gearbox.

1.0.8 All fittings and connections must be airtight. Otherwise, pump suction capability will be reduced or lost.

IMPORTANT: On single-phase units, the rotation is set at the factory and must not be changed

NOTE: THE FACTORY SUPPLIED CHECK VALVES ARE FITTED WITH VITON O-RINGS. CHECK CHEMICAL COMPATIBILITY, IF NOT COMPATIBLE REPLACE WITH SUPPLIED TEFLON O-RINGS.

All piping systems should include:

- 1.1.1 A separate system relief valve to protect piping and process equipment, including the pump, from excess process pressures.
- *An **external relief valve** is required to safeguard pump and the piping system.
- 1.1.2 Isolation valves and unions (or flanges) on suction and discharge piping. This permits check valve inspection without draining long runs of piping. Isolation valves should be of the same size as connecting pipe. Full flow ball valves are preferred since they offer minimum flow restriction.
- 1.1.3 An inlet strainer, if the product is not slurry. Pump check valves are susceptible to dirt and other solid contaminants unless designed for that service, and any accumulation can cause malfunction. The strainer should be located between the suction isolation valve and the pump suction check valve. It must be sized to accommodate the flow rate and the anticipated level of contamination. A 100-mesh screen size is recommended.
- 1.1.4 Check valve housings or other portions of the liquid head must not support piping weight, as the resulting stresses can cause leaks. In piping assembly, use a sealing compound chemically compatible with the process material.

SUCTION PRESSURE REQUIREMENTS

Although Mechanical Diaphragm metering pumps have suction lift capability, a flooded suction is preferable whenever possible. The pump should be located as close as possible to the suction side reservoir or other source keeping suction piping as short as possible.

The pump will self-prime with 10 ft. (3 meters) of water suction lift (wetted valves, zero back pressure, full stroke and speed, water like solutions). A foot valve is required to maintain prime. Once primed, the pump is capable of up to 20 feet (6 meters) of water suction lift.

Neptune Mechanically Actuated Diaphragm metering pumps are designed for continuous service at the rated discharge pressure. The discharge pressure must exceed suction pressure by at least 25 psiA (or 1.75 Bar). This can be achieved where necessary by the installation of a backpressure valve in the discharge line.

2.0 SUCTION PIPING

- 2.0.1 The suction piping to the pump must be absolutely airtight for optimum operation. Any leakage in the suction line will reduce or even eliminate pumping capacity. Suction pipe should be at least one size larger than suction port size of the pump's Liquid Head. It is suggested that the suction piping be tested with low air pressure and a soap solution to assure that no leaks exist. Limit the total length of the suction line to 5-8 feet for suction lift or 8-10 feet for flooded suction. Minimize bends, elbows, or other restrictions for better pumping efficiency.
- 2.0.2 NEPTUNE RECOMMENDS THAT THE MECHANICALLY ACTUATED DIAPHRAGM METERING PUMPS BE OPERATED WITH A FLOODED SUCTION, AS THIS WILL FACILITATE START-UP AND INCREASE THE SERVICE LIFE OF THE PUMP.
- 2.0.3 It is recommended that all solution tanks be furnished with a low level cut off switch or low-level alarm and cut off switch to prevent the pump from running dry. Although the pump can run dry for a few minutes, OPERATION AGAINST A DRY SYSTEM UNDER PRESSURE FOR A PROLONGED PERIOD MAY CAUSE DAMAGE TO THE PUMP DIAPHRAGM AND REDUCE THE OPERATING LIFE OF THE PUMP.

3.0 DISCHARGE PIPING

- 3.0.1 It is recommended that the Mechanically Actuated Diaphragm metering pump operate against a suitable back pressure to facilitate better operation of the check valves.
- 3.0.2 To protect the pump, it is recommended that an external relief valve as manufactured by Neptune Chemical Pump Company, or equal, be placed in the discharge line of the pump to avoid over pressure.
- 3.0.3 Discharge piping should at least equal to discharge port size of the pump's Liquid Head.

NOTE: All pipes and valves must have a working pressure at least twice the system maximum pressure.

CAUTION: Do not attempt to run the pump in excess of its nameplate rating.

4.0 INSTALLATION OUTDOORS

The Mechanically Actuated Diaphragm metering pump is a totally enclosed pump, which can be used outdoors or indoors. When installed outdoors, make sure that the pump is protected against extremes of nature as follows:

- 4.0.1 Running of the pump when exposed to tropical sunshine with ambient temperature above 100°F (37.8°C) would cause excessive motor temperatures. The pump should be shaded and located in such a way as to permit an ample degree of air circulation.

5.0 START UP PROCEDURE

The following start up procedure is complete and does repeat instructions on filling the gearbox and pump.

- 5.0.1 Open suction and discharge valves. (See recommendation 1.0.5)
- 5.0.2 Set capacity control knob to indicate zero by turning clockwise.
- 5.0.3 Adjust backpressure close to zero.
- 5.0.4 Start pump.
- 5.0.5 On initial start-ups: Check for proper motor rotation (Refer to Paragraph 1.0.6). Listen for any abnormal motor or crank noises, and if present, refer to trouble shooting chart (page 21)
- 5.0.6 Adjust pump to required capacity by turning hand knob counterclockwise.
- 5.0.7 Adjust system pressure to requirement.

SECTION III

NORMAL MAINTENANCE

6.0 MAINTENANCE

CAUTION - Ensure all operators are properly trained and employ safe operating and maintenance practices. Operator error may cause process liquid to expel through the head joints and/ or piping.

Under normal conditions, the Mechanically Actuated Diaphragm metering pumps should not require any significant amount of maintenance. The liquid end of the pump should also be inspected for leakage and check the liquid head bolt torque. These observations should be made regularly.

6.1.0 CHECK VALVE REMOVAL CLEANING AND REPLACEMENT.

Should the valves need cleaning, remove as follows:

- 6.1.1 Disconnect the power source to the drive motor.
- 6.1.2 Relieve all pressure from the piping system.
- 6.1.3 Close the isolation valves on suction and discharge piping.
- 6.1.4 Loosen and remove the suction and discharge check valves gradually to drain any trapped liquid.
- 6.1.5 Clean valves with suitable solvent. Both valves are complete and integral units and should not be disassembled for cleaning. If the valves are found to be worn and in need of replacement, an entire valve in either suction or discharge should be ordered.
- 6.1.6 To replace, reverse above procedures. Make sure that the port orientation is correct.
- 6.1.7 For valves with O-rings make sure that the O-rings are in good condition. Install new O-rings if necessary.

6.2.0 LIQUID HEAD REMOVAL, INSPECTION, AND REINSTALLATION

CAUTION: If the diaphragm failed, process fluid will pass through the bleed hole located behind the diaphragm. Handle any liquid with appropriate care. (Refer to liquid manufacturer's SDS)

Mechanical diaphragms should operate for approximately 2000+ hours under normal operating conditions; however, the accumulation of foreign material or debris and abnormal operating condition or simply age can cause failure. Failure can also occur as a result of hot pumping fluid or system over pressure. Periodic diaphragm inspection and replacement are recommended.

- 6.2.1 Adjust the stroke control knob to "0" and disconnect the power source to the drive motor.
- 6.2.2 Relieve all system pressure from the piping system.
- 6.2.3 Take all precautions described under "Caution" to prevent environmental and personnel exposure to hazardous materials.
- 6.2.4 Disconnect piping to the Liquid Head and drain any process liquid.
- 6.2.5 Place a pan underneath the pump head adaptor to catch any liquid leakage.
- 6.2.6 Remove all but two top Liquid Head bolt. Process fluid will leak out between the pump head

adaptor and Liquid Head as the bolts are loosened.

- 6.2.7 Tilt the head and pour out any liquids retained by the check valves into a suitable container, continue to follow safety precautions as appropriate.
- 6.2.8 Remove the final bolt and rinse or clean the Liquid Head with an appropriate material.
- 6.2.9 Inspect the diaphragm. The diaphragm must be replaced if it is cracked, separated, or obviously damaged. Remove the diaphragm if necessary, by turning counter-clockwise.
- 6.2.10 To install a diaphragm, first ensure that the critical sealing areas of: diaphragm, Liquid Head, and pump head adapter are clean and free of debris. Assemble the diaphragm with backup plate (item #35). For MP7015-D3N, 5, 8 install spacer nut (item #50) onto the diaphragm threads.
- 6.2.11 Thread the diaphragm (clockwise) completely on the push rod.
- 6.2.12 Install the liquid head, faceplate (for plastic heads), and bolts. Tighten bolts in an alternating crossing pattern to ensure an even pressure on all bolts. Recommended torque is 12-13 ft-lb for heads on MP7015-DN3, DN5, N8 pumps.
- 6.3.0 Apply Anti-seize at motor shaft and gear shaft adapter.

**MODEL MP7007-BN3 MECHANICALLY ACTUATED PUMP
(SHOWN WITH "B" 316SS LIQUID HEAD)**

VERTICAL CROSS SECTION

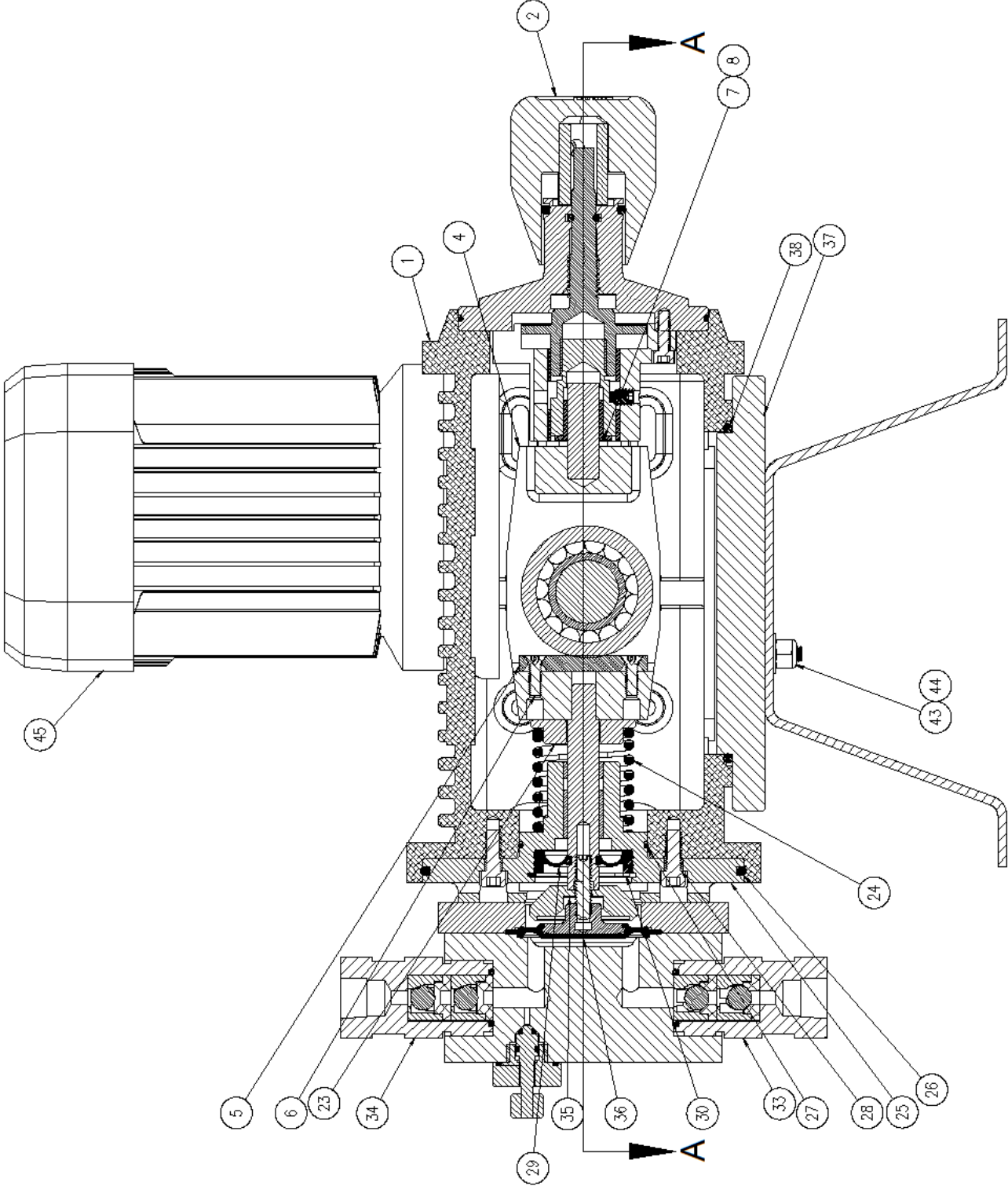

HORIZONTAL CROSS SECTION A-A

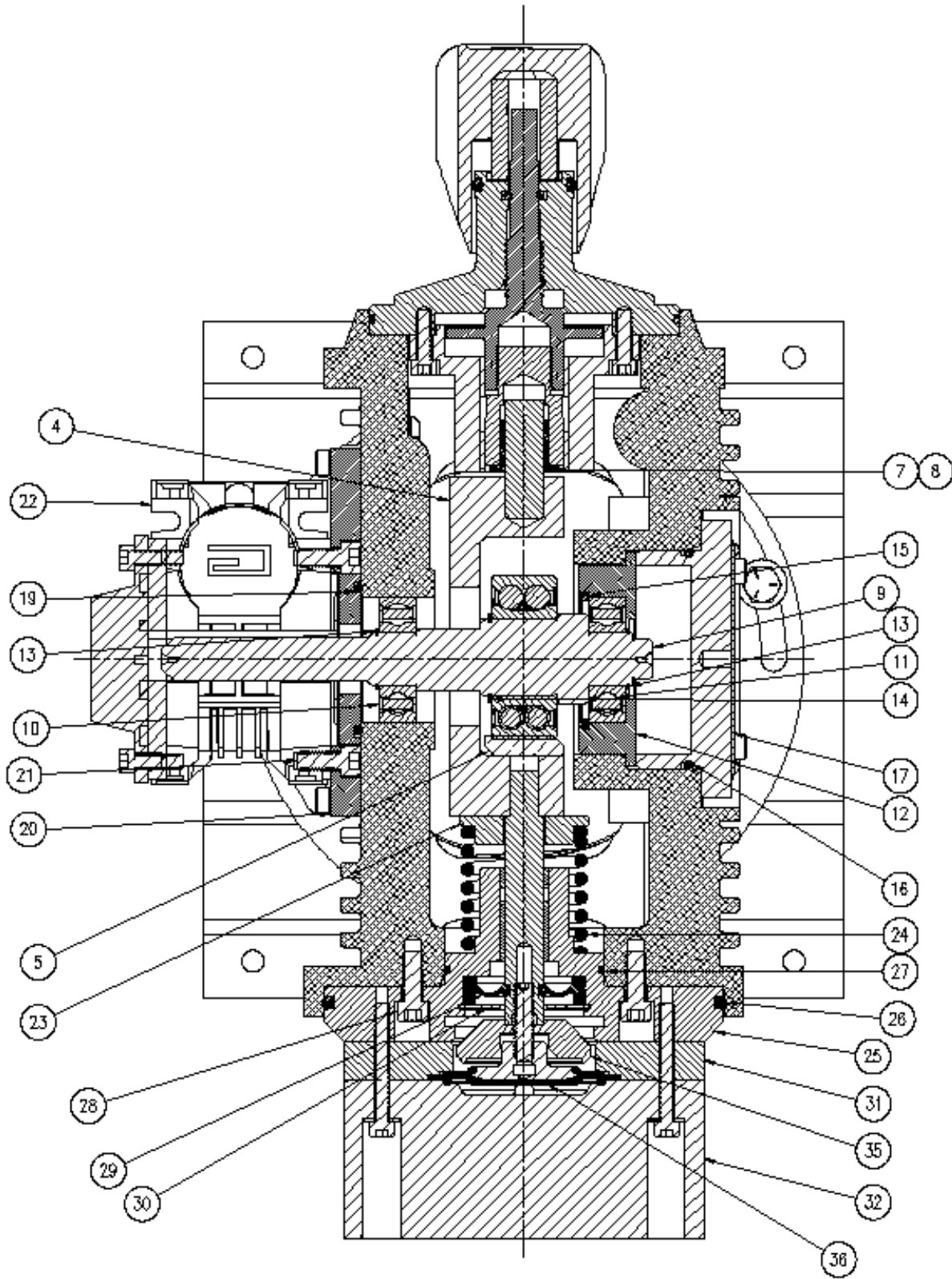

PUMP SIDE VIEW (LEFT SIDE)

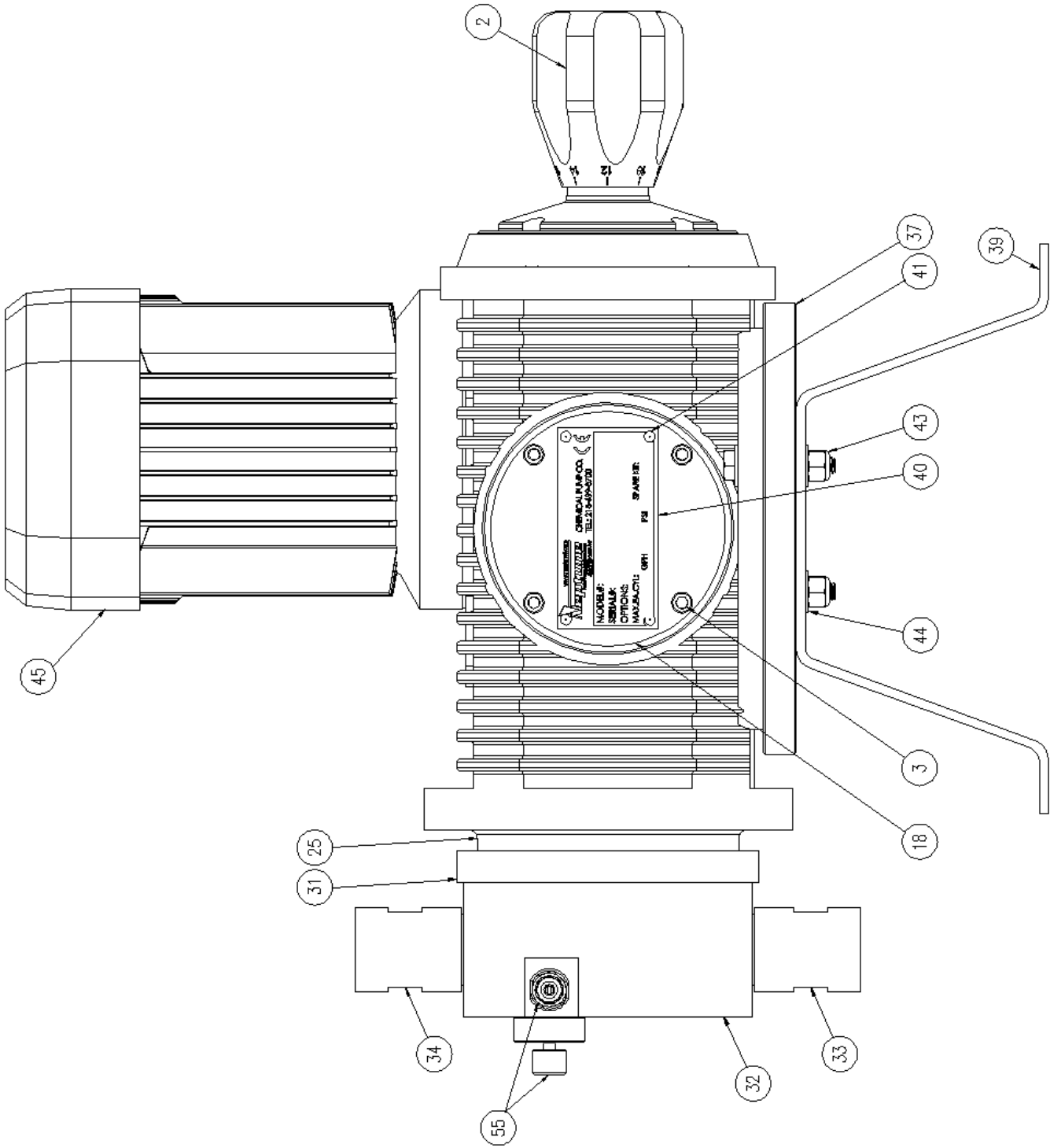

PARTS LIST

COMMON PARTS LIST

ITEM NO.	PART NO.	DESCRIPTION	QTY
1	004960	LOW VOLUME MAD PUMP BODY	1
2	004987	STROKE CONTROL ASSEMBLY MP7000	1
4	106106	SHCS 10-32 X 5/8	10
5	004990	CARRIER PLATE ASSEMBLY MP7000	1
7	005196	WEAR STRIP MP7000	1
8	129313	FHCS 10-32 X 1/2"	2
12	121081	BEARING 6203 17MM	2
13	121080	BEARING 5205 20MM	1
14	004956	BEARING HOLDER, MP7000, PUMPS	1
15	121082	EXTERNAL RETAINING RING	1
16	121083	EXTERNAL RETAINING RING	1
17	121084	INTERNAL RETAINING RING	1
18	105532	O-RING BUNA #2-145	1
19	004958	SIDE COVER MP7000	1
20	121200	KEY 5MM SQ. X 40MM ROUND ENDS	1
21	121202	O-RING VITON #2-131	1
22	004966	MOUNTING FLANGE GEARBOX MP7000	1
23	121198	SHCS M6 X 14MM	4
25	004964	SPRING GUIDE MP7000	1
26	121089	SPRING	1
27	005343	FRONT COVER MP7000 PUMP	1
28	121125	O-RING VITON #2-246	1
29	106693	O-RING VITON #2-031	1
30	100211	SHCS 1/4-20 X 5/8	4
31	121111	SECONDARY DIAPHRAGM	1
32	121204	RETAINING RING INTERNAL 1-1/2" BORE	1
39	004989	BASE ADAPTER FOR L.V. PUMP	1
40	104563	O-RING VITON #2-250	1
41	104637	STEEL BASE	1
42	109962	PUMP TAG	1
43	100209	DRIVE CREW	4
44	100106	HEX HEAD PLTD SCREW 1/4-20 X 1 1/2"LG	2
45	106539	1/4-20 HEX NUT/NYLON/WHITE	2
46	108426	WASHER FLAT 1/4 316SS	4
48	129874	SHCS 10-32 X 1 1/2" LG	6
49	129875	FLAT WASHER #10	6

PARTS LIST PER MODEL

“A” PUMPS MP7007-AN3, -AN5, -AN8

ITEM NO.	PART NO.	DESCRIPTION	QTY
2	004987	STROKE CONTROL ASSEMBLY MP7000	1
7	129863	SHIM SPRING STEEL 1/2 X 3/4 X .010	2
9	004955	CAM SHAFT, MP7000, .125"	1
22	129423	RIGHT ANGLE GEARBOX, 7.5:1	1
31	004969	HEAD ADAPTER, MP7000	1
32	005384	LIQUID HEAD MP7000, A, 316SS	1
	005375	LIQUID HEAD MP7000, A, PVC	1
	005387	LIQUID HEAD MP7000, A, PVDF	1
33	005207	CHECK VALVE MP7000, A, 316SS SUCTION	1
	005205	CHECK VALVE MP7000, A, PVC SUCTION	1
	005206	CHECK VALVE MP7000, A, PVDF SUCTION	1
34	005210	CHECK VALVE MP7000, A, 316SS DISCHARGE	1
	005208	CHECK VALVE MP7000, A, PVC DISCHARGE	1
	005209	CHECK VALVE MP7000, A, PVDF DISCHARGE	1
35	004967	BACKUP PLATE MP7000	1
36	005338	"A" DIAPHRAGM ASSEMBLY	1

“B” PUMPS MP70XX-BN3, -BN5, -BN8

ITEM NO.	PART NO.	DESCRIPTION	QTY
2	004987	STROKE CONTROL ASSEMBLY MP7000	1
7	129863	SHIM SPRING STEEL 1/2 X 3/4 X .010	1
8	129864	SHIM SPRING STEEL 1/2 X 3/4 X .005	1
9	004955	CAM SHAFT, MP7000, .125"	1
22	129423	RIGHT ANGLE GEARBOX, 7.5:1	1
	129424	RIGHT ANGLE GEARBOX, 10:1	1
	129425	RIGHT ANGLE GEARBOX, 15:1	1
31	004970	HEAD ADAPTER, MP7000	1
32	005385	LIQUID HEAD MP7000, B, 316SS	1
	005376	LIQUID HEAD MP7000, B, PVC	1
	005388	LIQUID HEAD MP7000, B, PVDF	1
33	005299	CHECK VALVE MP7000, B, 316SS SUCTION	1
	005297	CHECK VALVE MP7000, B, PVC SUCTION	1
	005298	CHECK VALVE MP7000, B PVDF SUCTION	1
34	005302	CHECK VALVE MP7000, B, 316SS DISCHARGE	1
	005300	CHECK VALVE MP7000, B, PVC DISCHARGE	1
	005301	CHECK VALVE MP7000, B, PVDF DISCHARGE	1
35	004968	BACKUP PLATE MP7000	1
36	005339	"B" DIAPHRAGM ASSEMBLY	1

“C” PUMPS MP70XX-CN3, -CN5, -CN8

ITEM NO.	PART NO.	DESCRIPTION	QTY
2	004987	STROKE CONTROL ASSEMBLY MP7000	1
9	005378	CAM SHAFT, MP7000, .105"	1
22	129423	RIGHT ANGLE GEARBOX, 7.5:1	1
	129424	RIGHT ANGLE GEARBOX, 10:1	1
	129425	RIGHT ANGLE GEARBOX, 15:1	1
31	005200	HEAD ADAPTER, MP7000	1
32	005386	LIQUID HEAD MP7000, C, 316SS	1
	005377	LIQUID HEAD MP7000, C, PVC	1
	005389	LIQUID HEAD MP7000, C, PVDF	1
33	005225	CHECK VALVE MP7000, C, 316SS SUCTION	1
	005213	CHECK VALVE MP7000, C, PVC SUCTION	1
	005219	CHECK VALVE MP7000, C PVDF SUCTION	1
34	005226	CHECK VALVE MP7000, C, 316SS DISCHARGE	1
	005214	CHECK VALVE MP7000, C, PVC DISCHARGE	1
	005220	CHECK VALVE MP7000, C, PVDF DISCHARGE	1
35	005199	BACKUP PLATE MP7000	1
36	005340	"C" DIAPHRAGM ASSEMBLY	1

PRIMING VALVE KITS FOR “A”, “B” & “C” PUMP HEADS

ITEM NO.	PART NO.	DESCRIPTION	QTY
55	005409	PRIMING VALVE KIT 316SS	1
	005410	PRIMING VALVE KIT PVC	1
	005411	PRIMING VALVE KIT PVDF	1

FOOT VALVES FOR “A”, “B” & “C” PUMPS (OPTIONAL)

ITEM NO.	PART NO.	DESCRIPTION	QTY
56 (Not Shown)	005407	FOOT VALVE ASSEMBLY 316SS	1
	005406	FOOT VALVE ASSEMBLY PVC	1
	005408	FOOT VALVE ASSEMBLY PVDF	1

“D” PUMPS MP7015-DN3, -DN5, -DN8, HEAD SECTIONS

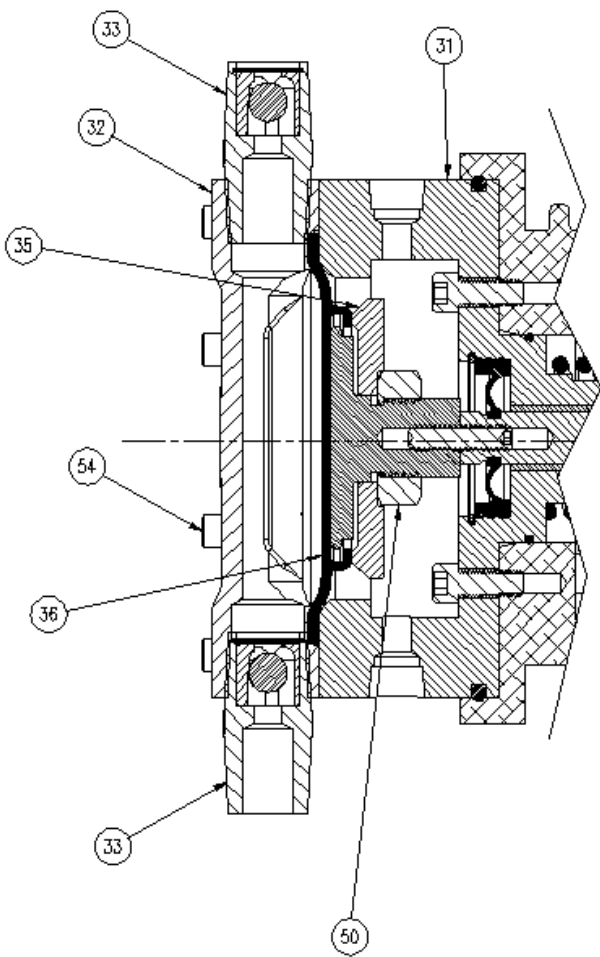

“D” PUMPS MP7015-DN3

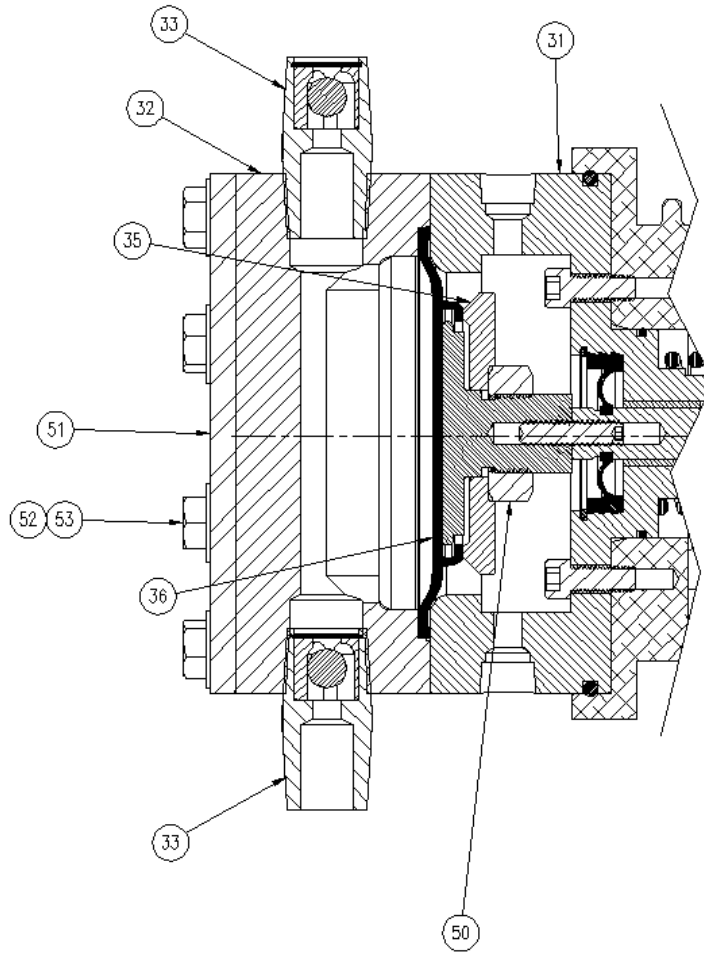

“D” PUMPS MP7015-DN5, -DN8

“D” PUMPS MP70XX-DN3, -DN5, -DN8

ITEM NO.	PART NO.	DESCRIPTION	QTY
2	005020	STROKE CONTROL ASSEMBLY MP7000	1
9	005346	CAM SHAFT, MP7000, .5mm	1
22	129425	RIGHT ANGLE GEARBOX, 15:1	1
31	005349	HEAD ADAPTER, MP7000	1
32	005133	LIQUID HEAD MP7000, D, 316SS	1
	004950	LIQUID HEAD MP7000, D, PVC	1
	004951	LIQUID HEAD MP7000, D, PVDF	1
33	005011	CHECK VALVE MP7000, D, 316SS SUCTION	2
	003279	CHECK VALVE MP7000, D, PVC SUCTION	2
	003332	CHECK VALVE MP7000, D PVDF SUCTION	2
35	004774	BACKUP PLATE MP7000	1
36	005351	"D" DIAPHRAGM ASSEMBLY	1
50	104684	HEX JAM NUT 3/4-16	1
51	004858	HEAD PLATE (USED ON HEADS 5 & 8 ONLY)	1
52	106442	HEX HEAD BOLT 5/16-18 (USED ON HEADS 5 & 8 ONLY)	8
53	100069	FLAT WASHER 5/16 (USED ON HEADS 5 & 8 ONLY)	8
54	100206	SHCS 5/16-18 (USED ON HEAD 3 ONLY)	8

SECTION IV

MOTOR OPERATING CONDITIONS

7.0 The normal temperature rise for standard motors is 40°C above ambient temperature and, thus, it might appear that the motor is operating at a higher than normal temperature. This situation is normal.

Due to the high motor surface temperature (80°C), as a precaution to avoid burning skin, it is recommended to avoid touching the pump during operation. After shutting off pump, let the pump rest for 5 minutes before touching the motor.

As a precaution against motor overheating, it is recommended that the pump be located where adequate ventilation is available, It is also recommended that a **MOTOR STARTER WITH THE PROPER OVERLOAD PROTECTION BE SUPPLIED AS AN ADDITIONAL SAFETY DEVICE.**

SECTION V

TROUBLESHOOTING CHART

SYMPTOMS	CAUSES	REMEDIES
1. Pump Motor Will Not Operate.	A. Blown Fuse.	Check for short circuit or overload
	B. Open thermal overload device in starter.	Reset.
	C. Low liquid level in tank (where low level cut-off is used).	Fill tank.
	D. Broken wire.	Locate and repair.
	E. Low voltage.	Check for too light wiring.
2. Pump Does Not Deliver Rated Capacity	A. Starved suction.	Look for blockage in suction line.
	B. Leaky suction piping.	Replace suction piping with larger size. Pressure test, repair or replace defective piping.
	C. Excessive suction lift.	Rearrange equipment location to reduce suction lift.
	D. Liquid too close to boiling point.	Lower temperature or increase suction pressure slightly.
	E. Worn or dirty valves or seats, or both	Clean or replace valve assembly.
	F. Viscosity of liquid too high	1. Reduce viscosity by heating or other means 2. Increase size of suction piping 3. Increase suction pressure slightly
	G. Low discharge pressure	A minimum discharge pressure of 25 psi is required to insure proper capacity control Repair or replace piping.
3. Pump delivers erratically.	A. Leaky suction line.	Clean or replace valve assembly.
	B. Worn or dirty valves or seats, or both.	Increase backpressure.
	C. Excessive excursion of ball valves from seats (indicated by ball chatter).	Increase suction pressure.
	D. Insufficient suction pressure	Raise tank level.
	E. Liquid too close to boiling point,	Reduce temperature or raise suction pressure.
	F. Leaky system relief valve.	Repair or replace relief valve
4. Motor overheats thermal overload activates,	A. Power supply does not match motor.	Check power supply against motor nameplate data.
	B. Overload caused by operating pump beyond rated capacity	Check operating pressure against pump manufacturer data plate maximum rating
5. Noisy Operation 5.1. In Pump	A. Pump Valves.	Valves must move to open and close, and they will make a clicking noise as they operate. These noises are sometimes amplified by natural resonances in piping system. They are usually indications of normal valve functioning.
	5.2. In Gear Reducer	A. Pounding noise at high discharge pressure

SPARE PARTS KITS

ITEM NO.	DESCRIPTION	QTY.	PART NUMBER	
36	DIAPHRAGM "A" ASSEMBLY	1	005338	KIT NUMBER 005357 MP7007-AN3
33	CHECK VALVE ASSEMBLY SUCTION	1	005207	
34	CHECK VALVE ASSEMBLY DISCHARGE	1	005210	

ITEM NO.	DESCRIPTION	QTY.	PART NUMBER	
36	DIAPHRAGM "A" ASSEMBLY	1	005338	KIT NUMBER 005358 MP7007-AN5
33	CHECK VALVE ASSEMBLY SUCTION	1	005205	
34	CHECK VALVE ASSEMBLY DISCHARGE	1	005208	

ITEM NO.	DESCRIPTION	QTY.	PART NUMBER	
36	DIAPHRAGM "A" ASSEMBLY	1	005338	KIT NUMBER 005359 MP7007-AN8
33	CHECK VALVE ASSEMBLY SUCTION	1	005206	
34	CHECK VALVE ASSEMBLY DISCHARGE	1	005209	

ITEM NO.	DESCRIPTION	QTY.	PART NUMBER	
36	DIAPHRAGM "B" ASSEMBLY	1	005339	KIT NUMBER 005360 MP70XX-BN3
33	CHECK VALVE ASSEMBLY SUCTION	1	005299	
34	CHECK VALVE ASSEMBLY DISCHARGE	1	005302	

ITEM NO.	DESCRIPTION	QTY.	PART NUMBER	
36	DIAPHRAGM "B" ASSEMBLY	1	005339	KIT NUMBER 005361 MP70XX-BN5
33	CHECK VALVE ASSEMBLY SUCTION	1	005297	
34	CHECK VALVE ASSEMBLY DISCHARGE	1	005300	

ITEM NO.	DESCRIPTION	QTY.	PART NUMBER	
36	DIAPHRAGM "B" ASSEMBLY	1	005339	KIT NUMBER 005362 MP70XX-BN8
33	CHECK VALVE ASSEMBLY SUCTION	1	005298	
34	CHECK VALVE ASSEMBLY DISCHARGE	1	005301	

ITEM NO.	DESCRIPTION	QTY.	PART NUMBER	
36	DIAPHRAGM "C" ASSEMBLY	1	005340	KIT NUMBER 005363 MP70XX-CN3
33	CHECK VALVE ASSEMBLY SUCTION	1	005225	
34	CHECK VALVE ASSEMBLY DISCHARGE	1	005226	

ITEM NO.	DESCRIPTION	QTY.	PART NUMBER	
36	DIAPHRAGM "C" ASSEMBLY	1	005340	KIT NUMBER 005364 MP70XX-CN5
33	CHECK VALVE ASSEMBLY SUCTION	1	005213	
34	CHECK VALVE ASSEMBLY DISCHARGE	1	005214	

ITEM NO.	DESCRIPTION	QTY.	PART NUMBER	
36	DIAPHRAGM "C" ASSEMBLY	1	005340	KIT NUMBER 005365 MP70XX-CN8
33	CHECK VALVE ASSEMBLY SUCTION	1	005219	
34	CHECK VALVE ASSEMBLY DISCHARGE	1	005220	

ITEM NO.	DESCRIPTION	QTY.	PART NUMBER	
36	DIAPHRAGM "D" ASSEMBLY	1	005351	KIT NUMBER 005366 MP7015-DN3
33	CHECK VALVE ASSEMBLY	2	005011	

ITEM NO.	DESCRIPTION	QTY.	PART NUMBER	
36	DIAPHRAGM "D" ASSEMBLY	1	005351	KIT NUMBER 005367 MP7015-DN5
33	CHECK VALVE ASSEMBLY	2	003279	

ITEM NO.	DESCRIPTION	QTY.	PART NUMBER	
36	DIAPHRAGM "D" ASSEMBLY	1	005351	KIT NUMBER 005368 MP7015-DN8
33	CHECK VALVE ASSEMBLY	2	003332	

