

Overcoming Clean-In-Place Challenges in Hygienic Applications with Mouvex® H-FLO Series Pumps

June 2021

By Paul Cardon



Mouvex H-FLO Series
Eccentric Disc Pump

Clean-In-Place (CIP) Challenges

There are numerous challenges that must be overcome when cleaning a hygienic pump installation. This is especially true when using a clean-in-place (CIP) method. CIP involves a variety of cleaning and rinsing fluids that are dispensed from a CIP system, which could include a tank, dosing installation, controls and a CIP pump. The pump pushes different fluids (acid solutions, alkaline solutions, sanitizers, water, etc.) through piping, valves, filters and the process pump.

Typical phases of CIP include:

- Removal of gross debris/product recovery
- Pre-Rinse
- Detergent recirculation
- Intermediate rinse
- Second detergent recirculation
- Intermediate rinse
- Disinfection
- Final rinse

Depending on the industry or product, some of the phases mentioned above can be omitted. However, the process pump is submitted to all these phases, leading to several challenges.

- **Product Recovery** – Before effective CIP begins, the pump, as well as a major part of the process installation, can still be full of product. If the pump is unable to run dry and provide vacuum and compression effects, it won't be able to help with product recovery. Therefore, there is a need for using an alternative method for product recovery such as a pigging system. Pigging systems can help recover product left in specifically designed pipe sections, but not in valves, filters and pumps. Another alternative method is using water and air flushing, but this could create product contamination and waste risks.
- **CIP Flow Rate** - Determined by in-pipe velocity, the CIP flow rate is based on a minimum value, generally 1.5 to 3 m/s. Because the flow must be turbulent to provide efficient cleaning, the result is a CIP flow rate that is almost always much higher than the process flow rate. Consequently, most process pumps require a bypass. Without this bypass, the pump's internal pressure drop would be excessive. However, since the process for splitting the CIP flow rate between the pump and the bypass still has not been mastered, there's no guarantee that the pump will be properly cleaned.
- **Water Hammer** – In an ideal world, the CIP system would be located as close as possible to the process that needs to be cleaned. In reality, that's usually not the case, with the CIP system being located far away from the process. As a consequence, the CIP fluid gains speed before reaching the process. When the fluid does reach the process, it results in a great shock, which can severely damage the pump's mechanical seal and shafts.
- **Temperature Variations** – Temperature of the fluids used during CIP may vary from 20°C (70°F) up to 90°C (200°F). If the pump technology includes thin clearances, they will need to be enlarged in order to withstand temperature variations to avoid the pump's rotating parts galling during hot CIP phases. However, these enlarged clearances could affect pump performance during certain phases of the process. In addition, waiting times between the hot and cold CIP phases is also necessary to avoid pump blockage.

How the Mouvex Easy Clean System makes it easier!

Thanks to a variety of design features and benefits, Mouvex eccentric disc technology is intrinsically easier to clean than many other available pumping technologies.

- Very few parts that come in contact with the product: pump body, bellows, disc and cylinder
- No mechanical seal, stator or cardan that could retain product
- Fully drainable
- Cleanability recognized by major worldwide certifications and regulations such as EHEDG, EC-1935-2004, 3A and FDA

Now, thanks to an additional feature called the Easy Clean System (ECS), the new H-FLO Series pump is easier to clean than ever before (the ECS is already available for Mouvex SLS4 and SLS8 pumps).

How does The Easy Clean System work?

On an H-FLO Series or SLS Series pump equipped with an ECS, the transmission includes a pressurization capacity designed to be supplied with 4 bar (58 psi) of compressed air. The air supply leads to the opening of the pump interior, allowing the full CIP flow rate to cross through the pump with limited pressure drop.

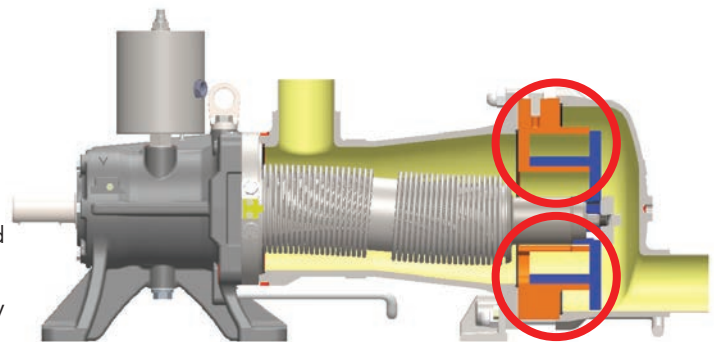

When transmission inside is at atmospheric pressure, disc is in contact with the cylinder.

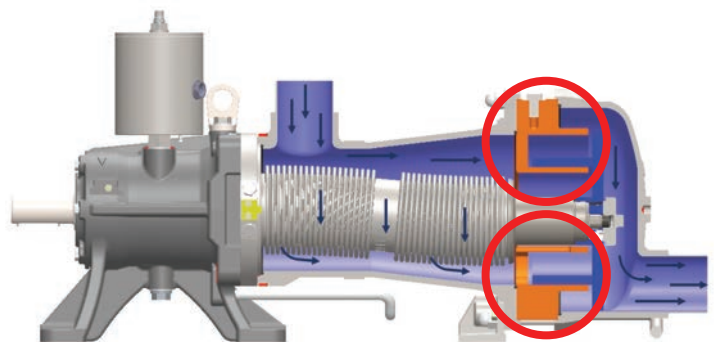

When compressed air is admitted inside the transmission, bellows stretches, pushing disc away from the cylinder.

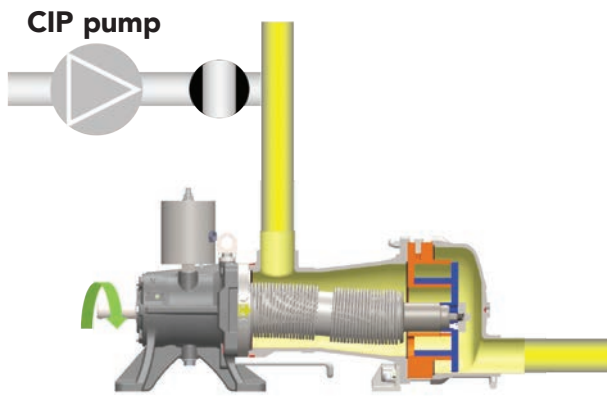

Process operation (product pumping)

During process operation, the transmission is not supplied with air. Disc remains against the cylinder to allow pumping action.

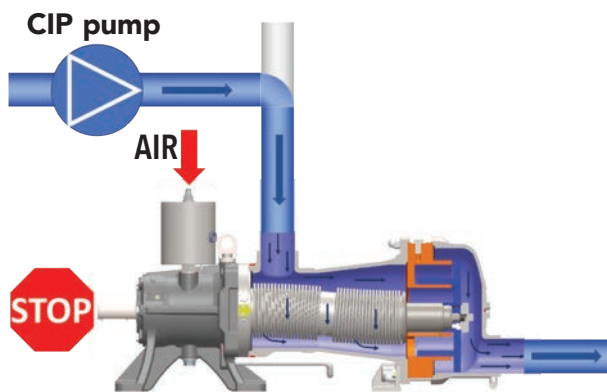

CIP or water flush

During a CIP or water flush, the pump is stopped, and the transmission is supplied with compressed air. This enables the disc to move away from the cylinder, letting the full CIP flow rate going through the pump.

How do Mouvex pumps equipped with the ECS overcome CIP challenges?

- Product recovery** – Mouvex pumps are able to provide greater product recovery benefits when compared to other positive displacement (PD) pump technologies, even without the ECS. Eccentric disc pump technology is ideal for optimizing product-recovery applications because its ability to pump air, which creates a vacuum effect on the pump's suction side and a compressor effect on the discharge side. This results in a plug effect that pushes a complete product "plug" out of the piping. This enables Mouvex pumps to recover product from transfer lines at rates of up to 95% on suction and 85% on discharge. There is also no risk of extra contamination as the pump uses air already in contact with the product. In addition to the product/cost savings achieved by enhanced product recovery, leaving a minimum amount of product in the process installation also makes cleaning easier while using less cleaning fluids like detergents, potable water, etc.

- CIP Flow Rate** – The ECS eliminates the need for CIP bypass and having the full CIP flow rate going through the pump. This allows the ECS to provide maximum efficiency for the pump cleaning. Full opening of the pump also dramatically reduces pressure drop.

Thanks to these benefits, pressure is available to clean the downstream line. Eliminating CIP bypass also

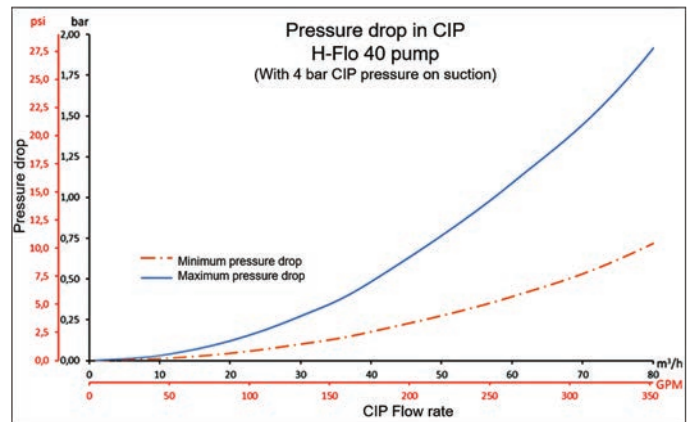

simplifies installation and makes it easier to clean, with less piping and less risks of product retention.

The ECS also does not need an additional energy source. The compressed air source, which was serving the CIP bypass valve actuator can be reused to drive the ECS.

- Water Hammer** – As already explained, the ECS works by pressurizing the bellows. This provides higher CIP pressure at the pump inlet (up to 6 bar/90 psi) and significantly improves resistance to water hammer.

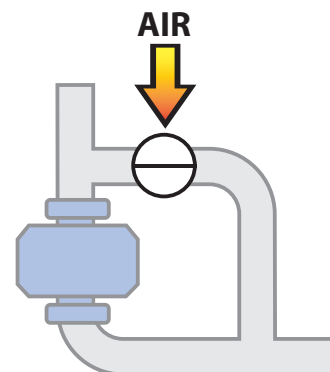

With most PD pumps:
CIP bypass

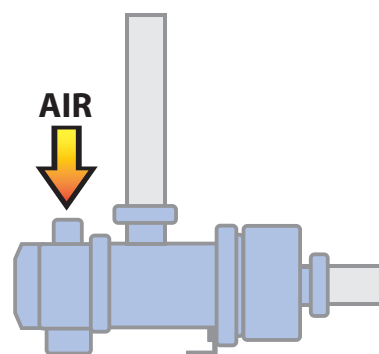

With a Mouvex pump:
No CIP bypass

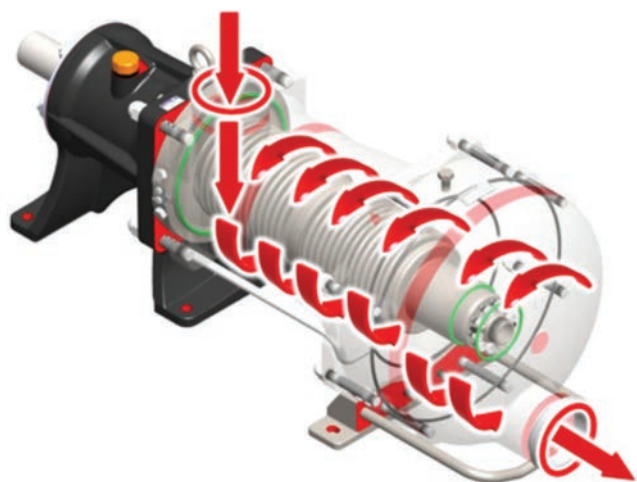

During lab testing, a pump fitted with the ECS has endured over 14,000 water hammer events without damage! In addition to this, the new H-Flo Series pump adds an additional improvement. The suction port is no longer centered but tangential. This provides better cleaning by centrifuge effect while reducing water hammer impact on the bellow to enhance reliability.

- **Temperature Variations** – On many pumping technologies, functional clearances are required to avoid pumping parts galling or blocking. On a Mouvox pump, there is no need for clearances because the parts are kept in permanent contact. So even with a 90°C (200°F) gap, there is no need to wait between hot and cold phases. The pump is also able to provide optimum performance for each phase of the process.

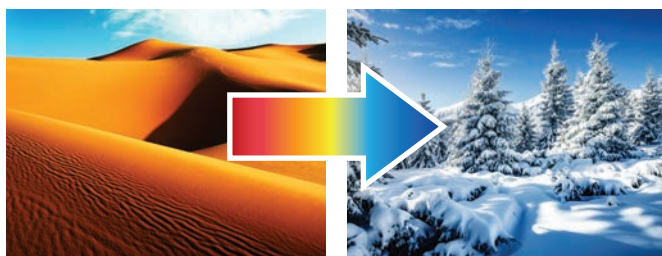

Conclusion

Thanks to the ECS, H-FLO Series pumps have now become one of the easiest hygienic pumps to clean on the market. The ECS reduces installation costs by eliminating the need for CIP bypass, and operational costs thanks to increased product recovery. In addition, the ECS provides a more efficient cleaning process while eliminating the consequences of water hammers. By adding the benefits of the ECS to the traditional advantages of Mouvox technology (seal-less design, self-adjustment, low shear, etc.) the new H-FLO Series is one of the most cost-effective pumping solutions on the market.



About the Author:

Paul Cardon is Business Development Manager PSG Auxerre - FRANCE. He can be reached at (+33 6 88 70 22 90) or paul.cardon@psgdover.com. Mouvox is a product brand of PSG®, a Dover company, Oakbrook Terrace, IL, USA. PSG is comprised of leading pump brands, including Abaque™, All-Flo, Almatec®, Blackmer®, Ebsray®, em-tec, EnviroGear®, Griswold®, Hydro Systems, Mouvox®, Neptune™, Quattroflow™, RedScrew™ and Wilden®. You can find more information on PSG at psgdover.com. Headquartered in Auxerre, France, Mouvox® is a leading manufacturer of positive displacement pumps and compressors for the transfer of liquids in hygienic-manufacturing applications worldwide. For more information on Mouvox, please visit mouvex.com.