

CHARACTERISTICS

	STANDARD		AVAILABLE OPTIONS
Technology	6 vanes		12 vanes + pushrods
Maximum Flow rate at 1 cSt in m ³ /h (GPM)	50 (220)		
Power requested (KW) and Torque (Nm) at 750rpm 8bar at 10Cst	10	127	
Power requested (KW) and Torque (Nm) at 1000rpm 4 bar at 10 Cst	6.5	62	
Cubic capacity L (cu.in)	0.887 (54.1281)		
By-pass	Simple, no reversible		Pneumatic, Pneumatic + spring
Rotation direction	CW or CCW (2 ended shafts)		
Ports	Flanges Ø 80		
Heating	Without		
Dimensions mm (in.)	A	443 (17.44)	
	B	224 (8.82)	
	C	318 (12.52)	
	D	112 (4.41)	
	E	145 (5.71)	
	F	120 (4.72)	
Weight kg (lbs)	48 (106)		

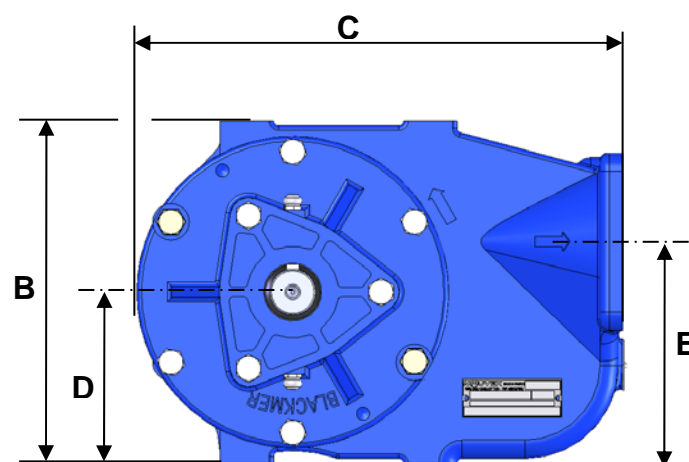
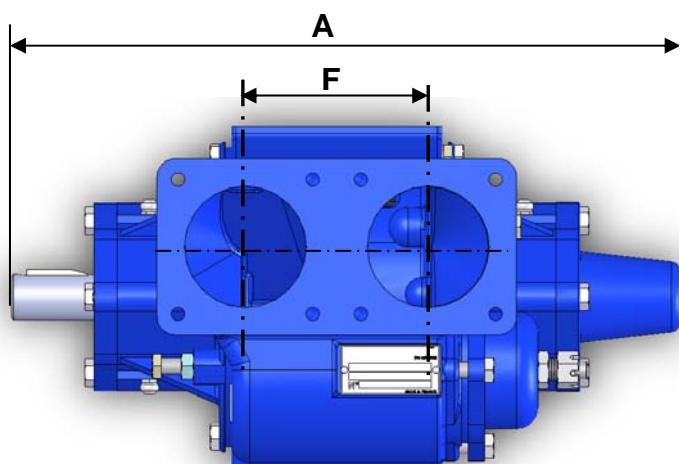

OPERATING LIMITS

	STANDARD MATERIALS
Minimum temperature °C (°F)	-20 (-4)
Maximum temperature °C (°F)	80 (176)
Maximum viscosity cSt (SSU)	50 (260) for 6 vanes, 1000 (4800) if 12 vane + pushrods
Maximum differential pressure bar (psi)	8 (116)
Minimum speed (rpm) without pushrods	450
Maximum speed (rpm) at 8 bar	750
Minimum speed (rpm) at 4 bar	1000

MATERIALS OF CONSTRUCTION

Part No	PART NAME	STANDARD MATERIAL	AVAILABLE OPTIONS
100	Casing	Cast Iron	
300	Rotor	Cast iron	
317	Vanes	PPS	PEEK
400	Ends	Cast iron	
500	Shaft	Steel	
703	Ball bearings	Steel	
	Static O-rings	Nitrile	FKM
630	Mechanical seal	Carbon / stainless steel	
630	Mechanical seal O-rings	FKM	FEP

