

Translation of the original instructions

# ***CENTREX MULTI 60 RM***



***INSTALLATION***

***OPERATION***

***MAINTENANCE***

# COMBINED AIR ELIMINATION AND CENTRIFUGAL PUMP

## SAFETY, STORAGE, INSTALLATION AND MAINTENANCE INSTRUCTIONS

### MODEL : CENTREX MULTI 60 RM



Group N° :
Commissioning date :

SUMMARY	Page
<b>1. OVERALL DIMENSIONS</b> .....	<b>3</b>
<b>2. INSTALLATION</b> .....	<b>4</b>
2.1 Fixing of the chassis .....	5
2.2 Connection of the pipes .....	5
2.3 Motor .....	5
2.4 Set below ground .....	5
2.5 Storage .....	5
<b>3. FEEDING</b> .....	<b>5</b>
3.1 Venting .....	5
3.2 Recovery of vapours .....	5
<b>4. DELIVERY</b> .....	<b>5</b>
<b>5. DIAPHRAGM</b> .....	<b>6</b>
<b>6. OPERATION</b> .....	<b>6</b>
6.1 Pumped products .....	6
<b>7. MAINTENANCE</b> .....	<b>6</b>
<b>8. INSPECTION</b> .....	<b>6</b>

#### SAFETY INFORMATIONS



#### This is a SAFETY ALERT SYMBOL

When you see this symbol on the product, or in the manual, look for one of the following signal words and be alert to the potential for personal injury, death or major property damage.



Warns of hazards that **WILL** cause serious personal injury, death or major property damage



Warns of hazards that **CAN** cause serious personal injury, death or major property damage.



Warns of hazards that **CAN** cause personal injury or property damage.

#### NOTICE

Indicates special instructions which are very important and must be followed.

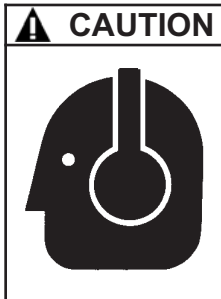

**THE NOISE GENERATED BY THE CENTREX UNIT CAN REACH 86 DB AT A DISTANCE OF 1 M. IT IS NECESSARY TO WEAR SOUND MUFFLERS IN THE VICINITY OF THE MACHINE.**



## 2. INSTALLATION

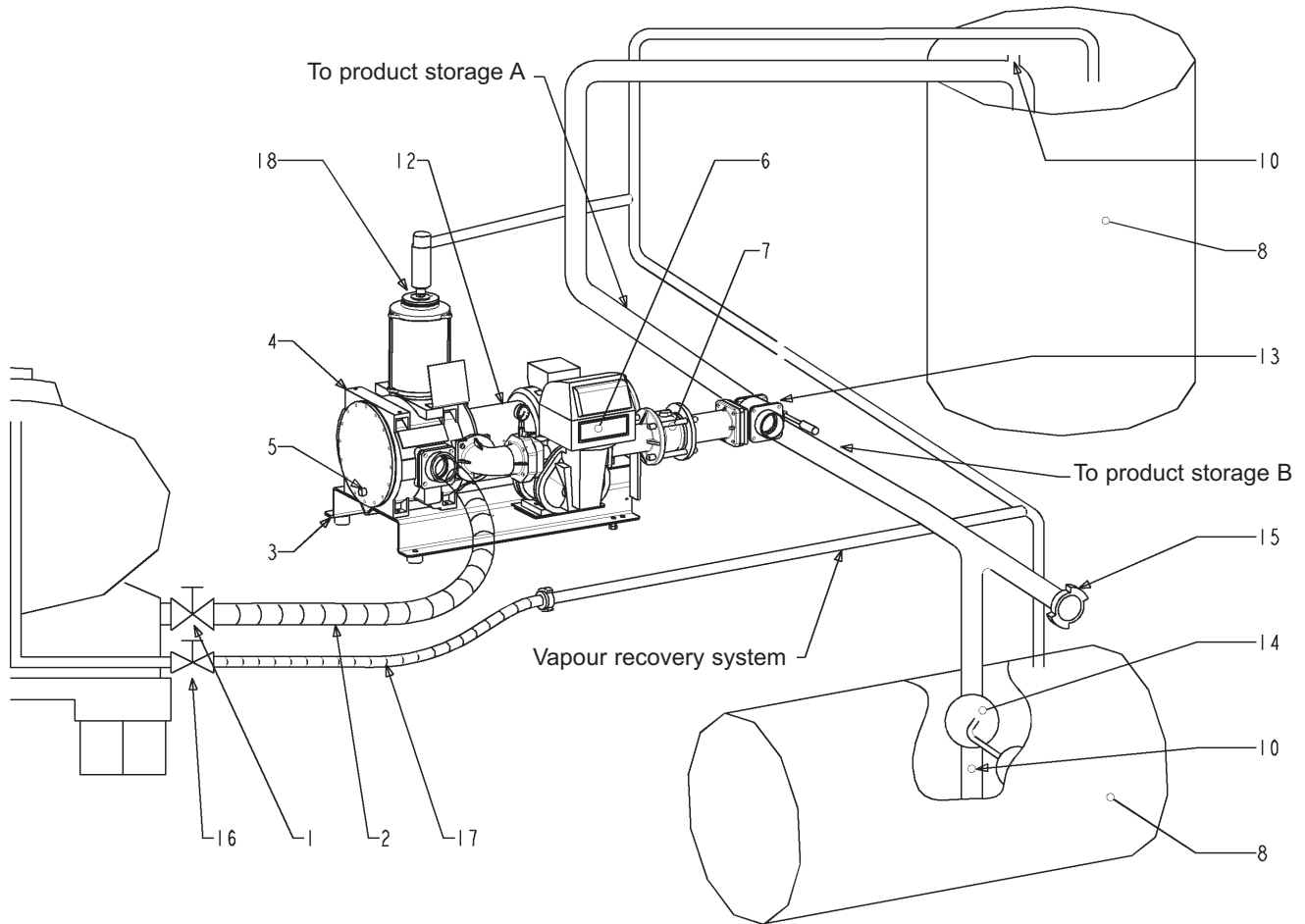

1	Vehicle draining valve
2	Hose
3	CENTREX MULTI assembly
4	CENTREX MULTI pump
5	Sighting device
6	Counter
7	Check valve
8	Storage
10	Orifice (avoid syphon effects)
12	Pressure gauge
13	3-way valve
14	Filling regulator
15	Gravity transfer
16	Vapour return valve
17	Vapour recovery
18	Dry degasser

---

## 2. INSTALLATION (continued)

Installation shall conform to the standard diagram approved by the French notified weight and measure body and be carried out by an installer who has received the authorization of the notified weight and measure body or our Technical Services department.

The primary inspection of each assembly can be carried out in the factory on request (**specific option**).

An identification and stamping plate is fixed to the assembly. The periodic inspection labels will be appended as and when the notified body carries out these inspections. If the unit is supplied without stamp, the user must have it approved on the site.

If the unit is supplied with stamp, the user shall notify the approved body of the start-up of the set within 5 days following this operation.

### 2.1 FIXING OF THE CHASSIS

Make sure that the chassis is horizontal and is in no way distorted by the fixing.

### 2.2 CONNECTION OF THE PIPES

The assembly is supplied with counter-flanges.

See to it that the pipes do not exert any abnormal stress on the set (if necessary, there could be brackets to support the pipes and valves).

### 2.3 MOTOR

This must be effectively protected from overloads by means of a suitably set circuit-breaker. During start-up, make sure that the strips in the terminal box are in the correct position. Please refer to the motor connection instructions.

### 2.4 SET BELOW GROUND

Clearance must be provided to permit dismantling (cf. Overall dimensions plan).

In all cases, the sightglass must remain visible so that it is possible to check whether or not there is product in the tank.

It is strongly recommended that the set should be properly protected and essential that there should be rain-water drainage.

### 2.5 STORAGE

The equipment awaiting installation must be stored in a dry sheltered place, with the counter protected by its cover if it has one.

---

## 3. FEEDING

Because the pump is of the centrifugal type without self-priming, it has to be gravity-fed ; it must therefore be positioned sufficiently low relative to the draining valves of the tanks from which delivery is being taken.

See to it that the connection to the draining valves of the tanks from which delivery is being taken is made with a hose with an inside  $\varnothing$  of at least 80 mm and a length not exceeding 6 m. For longer lengths, hoses of 100 mm  $\varnothing$  should be used.

### 3.1 VENTING

Venting to the atmosphere is provided by the degasser itself.

No connection is necessary.

### 3.2 RECOVERY OF VAPOURS

In the installations with vapour recovery the outlet from the degasser must be connected to the vapour recovery system by a suitable pipe which does not create excessive losses of head (pipe  $\varnothing$  1, minimum length)

Cf. plan § INSTALLATION.

---

## 4. DELIVERY

The diameter, length and accessories (elbow, T-piece, valve...) of the delivery pipe shall conform to the specifications defined at the time of the order. Our guarantee depends on this conformity.

The following should be provided in the delivery line :

- an isolating valve for each tank
- in regions subject to electrical power cuts and in the case of an underground tank, there should be a tapping point in the feed pipe of each tank to enable filling by gravity during any such mains disruptions. A flexible connection between the set and the pipeline of each tank will make this operation easier to perform by only having one hose to uncouple.

---

## 5. DIAPHRAGM

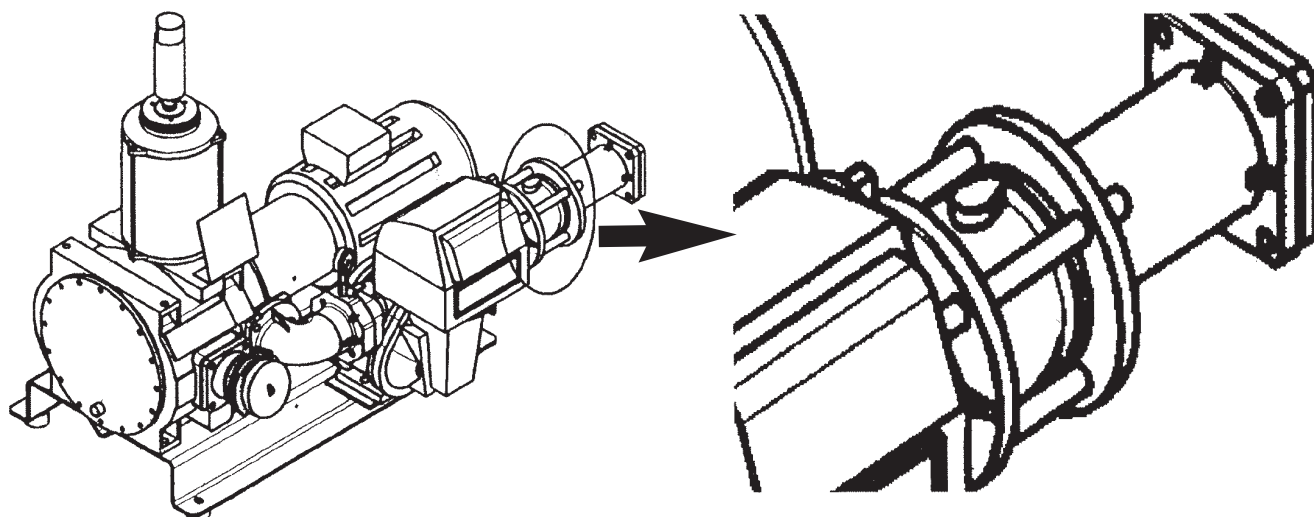

Flowrate is limited to 60 m<sup>3</sup>/h.

As a result of fact, the unit is preset in our workshop.

It is equipped with a 60 mm diameter diaphragm fitted between the no return valve outlet and its companion flange.

---

## 6. OPERATION

### 6.1 PUMPED PRODUCTS

There must be rigid conformity with the instructions defined in the equipment specification.

Apart from the general safety conditions which must be observed (earthing of the vehicle, etc...), metered receiving requires the following additional operations :

- Checking that there is no liquid in the sightglass ; if there is, the set is to be rotated until the liquid has been completely removed.
- Selection of the storage unit by means of the 3-way valve of the set (when there is one, optional with our equipment) depending on the nature of the product being delivered.
- Connection of the intake orifice of the set to the unloading valve of the filling tank by a hose.
- Opening of the unloading valve of the filling tank. The pump should not take more than 60 seconds to start priming. If it takes longer than this, cut off the Centrex unit's motor and look for the cause of the priming problem (closed valve, clogged filter...).

- If the counter is fitted with a ticket printer, insert the ticket in the counter and turn the actuation crank or knob.
- After total emptying (or partial take-off), closure of the unloading valve of the tanker. The group should not operate more than one minute with the discharge valve closed, or empty, once the liquid is no longer visible through the eyesight.
- Disconnection of the hose from the unloading valve of the tanker and dripping of the hoses into the pump.
- Shutting down of the set after it has been checked that the counter has stopped and liquid is no longer visible in the sightglass.
- Disconnection of the hose and replacement of the plug.

#### NOTE :

To print and recover the docket after the filling operation, rotate the crank or the actuation knob. The quantity of product received is obtained by subtraction of the 2 numbers printed on the docket.

---

## 7. MAINTENANCE

Periodic cleaning of the filter is all the maintenance needed. For the sets intended for the metering of FOD and (or) GO, use the special winter filter for the situation where waxing occurs in cold weather.

This filter can only be used for a short time. It must be replaced by the fine filter as soon as the climatic conditions allow.

---

## 8. INSPECTION

After initial verification carried out in the plant or at the site, the equipment is subject to periodic inspection by the notified Weights and Measures body.