



INSTRUCTIONS 1401-R00 e

Section	1401
Effective	April 2023
Replaces	April 2020

Original instructions

DDIC

Instructions for application

DIRECT DRIVE PACKAGE

MISTRAL - B600 - TYPHON II

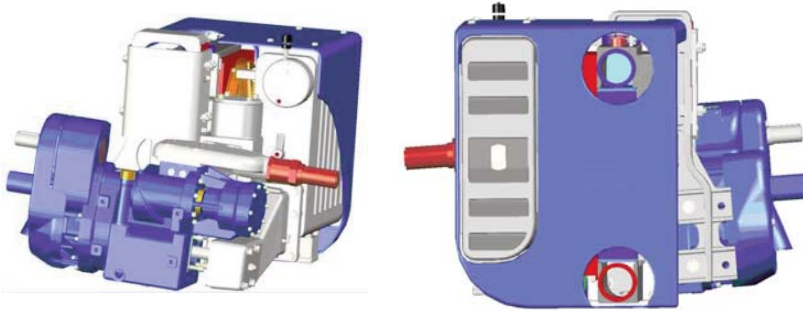

INSTALLATION
OPERATION
MAINTENANCE
SAFETY
STORAGE



This Instruction only contains direct drive package information. It is imperative to have in complement the compressor one and also all the others relatives to the accessories, also the parts list before installing the equipment.

EC CERTIFICATE OF CONFORMITY :

The EC Certificate of Conformity (paper version) is systematically attached to the equipment when shipped.

WARRANTY :

DDIC packages (except the compressor : see compressor Instructions) are covered 24 months by warranty within the limits mentioned in our General Sales Conditions. In case of a use other than that mentioned in the Instructions manual, and without preliminary agreement of MOUVEX, warranty will be canceled.

Warranty extension with oil BSC3 : See § WARRANTY.



Z.I. La Plaine des Isles - F 89000 AUXERRE - FRANCE
Tel. : +33 (0)3.86.49.86.30 - Fax : +33 (0)3.86.49.87.17
contact.mouvex@psgdover.com - www.mouvex.com

Your distributor :

MOUVEX TRUCK SCREW COMPRESSOR

SAFETY, STORAGE, INSTALLATION, OPERATION AND MAINTENANCE INSTRUCTIONS

MODELS : DDIC

DIRECT DRIVE PACKAGE

MISTRAL - B600 - TYPHON II

TABLE OF CONTENTS	Page
1. OVERALL DIMENSIONS	4
2. INSTALLATION	10
2.1 Mounting location	10
2.2 Mounting procedure	10
2.3 At suction	11
2.4 Check relief / Safety valve	12
2.5 Drive	12
2.6 Electric circuit	14
2.7 Instrumentation	14
2.8 Chair modification	14
3. USE	14
4. MAINTENANCE	15
4.1 Maintenance schedules	15
4.2 Air filter replacement procedure	15
4.3 Cartridge replacement procedure	15
4.4 Drive train inspection	15
4.5 Check and relief valve inspection	15
5. WARRANTY	15
5.1 Warranty claims	15
5.2 24-months warranty extension with BSC3 oil	15
6. TROUBLESHOOTING	16
7. STORAGE CONDITIONS	16
7.1 Compressor	16
7.2 BSC oil	16
8. SCRAPPING	16
9. COMPRESSORS FORM INFORMATION	17

Definition of safety symbols



This is a SAFETY ALERT SYMBOL.

When you see this symbol on the product, or in the manual, look for one of the following signal words and be alert to the potential for personal injury, death or major property damage.



Warns of hazards that WILL cause serious personal injury, death or major property damage.



Warns of hazards that CAN cause serious personal injury, death or major property damage.



Warns of hazards that CAN cause personal injury or property damage.

NOTICE

Indicates special instructions which are very important and must be followed.

ADDITIONAL DOCUMENTATION

The table below gives the list of instructions in addition to this application instruction :

DDIC application	Instructions	Parts list
B600 20R/30R	NT 1401-K00	PL 1401-K01 PL 1401-R01
B600 13R/15L B600 19R/22L	NT 1401-K00	PL 1401-K01 PL 1401-Q01 PL 1401-R01
MISTRAL 20R/30R	NT 1401-J00	PL 1401-J01 PL 1401-R01
MISTRAL 13R/15L MISTRAL 19R/22L	NT 1401-J00	PL 1401-J01 PL 1401-Q01 PL 1401-R01
TYPHON II 20R/30R	NT 1401-G00	PL 1401-G01 PL 1401-R01
TYPHON II 13R/15L TYPHON II 19R/22L	NT 1401-G00	PL 1401-G01 PL 1401-Q01 PL 1401-R01
Torque limiter	NT 1401-B00	PL 1401-Q01
Check and relief valve	NT 1401-E00	PL 1401-Q01
Oil cooler	NT 1401-AC00	PL 1401-Q01
Air cooler	NT 1401-AJ00	-

REMARKS :

MOUVEX truck screw-type compressors MUST be installed in systems designed by qualified personnel. The installation MUST be in compliance with local standards, national regulations and rules of safety.













This package is designed to be used on paved roads. Unless, it is necessary to move towards a package DDK to achieve a strengthened and adapted to the situation set.

This manual is designed to permit installation and commissioning of MOUVEX truck screw-type compressors and MUST accompany the compressor.

Maintenance of MOUVEX screw-type compressors must ONLY be carried out by qualified technicians. This maintenance must meet local and national standards as well as all safety regulations. Read this manual, including all instructions and warnings, in full BEFORE any use of MOUVEX compressors.

Reading and the removal of the labels on the package apply to approval.

SAFETY DATA

 <p>WARNING</p>		<p>IT IS IMPERATIVE TO APPLY THE TRUCK PARKING BRAKE AND TO BLOCK THE WHEELS BEFORE ANY INTERVENTION DUE TO RISKS OF SERIOUS BODILY INJURIES OR PROPERTY DAMAGE.</p>
<p>Hazardous machinery can cause severe personal injury or property damage.</p>		
 <p>WARNING</p>		<p>COMPRESSING GASES INTO A VESSEL CONTAINING FLAMMABLE OR EXPLOSIVE GASES OR COMPRESSING FLAMMABLE OR EXPLOSIVE GASES, CAN CAUSE PROPERTY DAMAGE, PERSONAL INJURY OR DEATH.</p>
<p>Hazardous fluids can cause fire, serious personal injury or property damage.</p>		
 <p>WARNING</p>		<p>FAILURE TO INSTALL ADEQUATELY SIZED PRESSURE RELIEF VALVE(S) CAN CAUSE PROPERTY DAMAGE, PERSONAL INJURY OR DEATH.</p>
<p>Hazardous pressure can cause personal injury or property damage.</p>		
 <p>CAUTION</p>		<p>COMPRESSOR, PIPING AND ACCESSORIES WILL BECOME HOT DURING OPERATION AND CAN CAUSE SERIOUS PERSONAL INJURY.</p>
<p>Extreme heat can cause injury or property damage.</p>		
 <p>WARNING</p>		<p>CONTENTS OF THE COMPRESSOR, TANK, PIPING, AND FILTERS COULD BE HAZARDOUS TO HEALTH. TAKE ALL NECESSARY PRECAUTIONS WHEN PERFORMING COMPRESSOR SERVICE OR MAINTENANCE.</p>
<p>Hazardous or toxic fluids can cause serious injury.</p>		
 <p>WARNING</p>		<p>THE NOISE EMITTED BY WORKING MOVEX SCREW COMPRESSOR CAN BE HIGHER THAN 80 DBA. THE END USERS MUST USE, WHEN NECESSARY THE APPROPRIATE EAR PROTECTIONS. FAILURE TO WEAR HEAR PROTECTIONS IN AREAS WHERE THE NOISE IS HIGHER THAN 80 DBA CAN LEAD TO PERMANENT BODY DAMAGE.</p>
<p>A loud noise can cause permanent body damage.</p>		

SAFETY CHECK LIST

1. Before operating the compressor, ensure the vessel to which the compressor is connected is certified to withstand the pressure and /or vacuum produced.
2. Verify adequately sized relief valves (if necessary, CE approved) have been fitted to protect the vessel. Do not use solvents or inflammable products for cleaning the pipelines and the accessories.
3. Gas/air mixtures which are potentially volatile/explosive must not be introduced or allowed to be introduced into the compressor.
4. All pressure vessel and piping connected to the compressor must be isolated and in a safe operating condition.
5. Operators should wear ear protection when operating truck mounted compressors.
6. There are components within the compressor of sufficient weight to cause injury if mishandled. Use proper lifting devices as necessary.
7. Where necessary, this equipment should be grounded to control static electricity.
8. The temperature of the air leaving the compressor is elevated above ambient due to air compression. Check that the elevated temperatures do not adversely affect the product and any material used in design of the system. Attach clearly marked warning signs to warn of potentially hot surfaces on the compressor, piping and accessories which will burn if touched.
9. Mounting of the compressor must be correctly engineered and the compressor must be properly secured. Refer to the Compressor Mounting section of this manual.

NOTICE :

MOVEX PACKAGE COMPRESSORS ARE DESIGNED TO PRODUCE COMPRESSED AIR. NOT TO PUMP GASES, LIQUIDS, POWDERS OR CONDENSATES THROUGH THE COMPRESSOR. TO DO SO WOULD VOID THE WARRANTY.

LIFTING POINTS :

The compressor can be picked up from underneath to be transported.



Those areas are acceptable to support the package. Compressor and chair support should be favored.

1. OVERALL DIMENSIONS

B600 20R - 30R DDIC

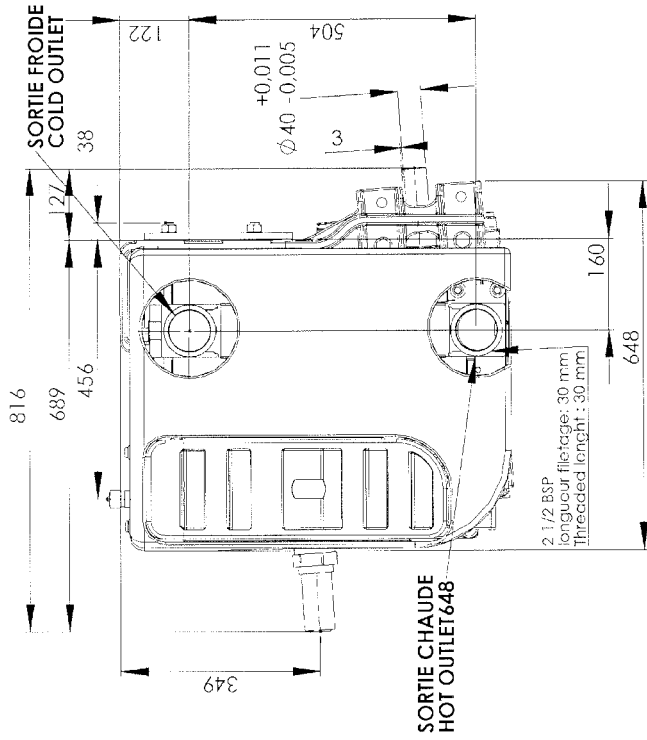

Poids avec limiteur de couple
Weight with torque limiter :
257 kg

DÉTAIL E

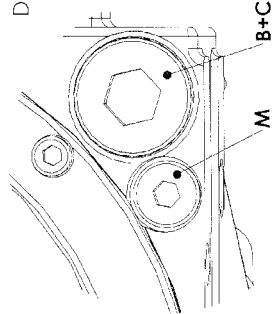

A	Jauge d'huile / Oil gauge
B	Filter à huile / Oil filter
C	Vidange / Draining cap
D	Contrôle pression refoulement G1/4"
E	Outlet pressure control G1/4"
F	Contrôle T° refoulement G1/4"
G	Outlet T° control G1/4"
H	Plaque signalétique / Identification plate
J	Prise pression huile / Oil pressure plug
K	Bouchon 3/4" (pour montage jauge d'huile à droite) 3/4" cap for right oil gauge installation
L	Prise vitesse G1/4" / Speed control G1/4"
M	Contrôle pression aspiration G1/4" Inlet pressure control G1/4"
	Contrôle T° aspiration G1/4" / Inlet T° control G1/4"
	Bouchon magnétique G3/8" / Magnetic plug G3/8"

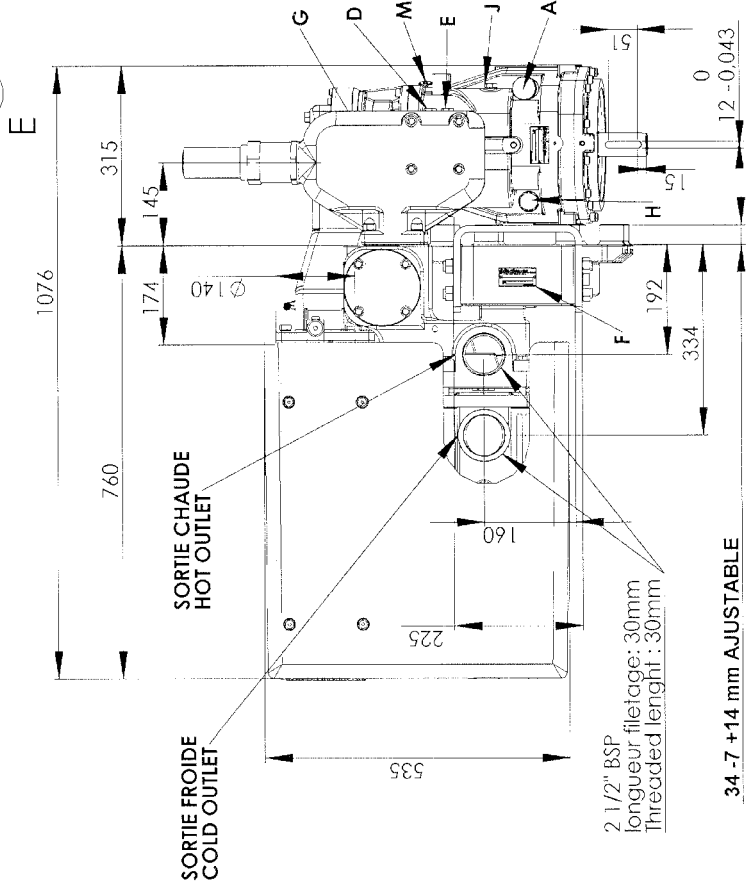
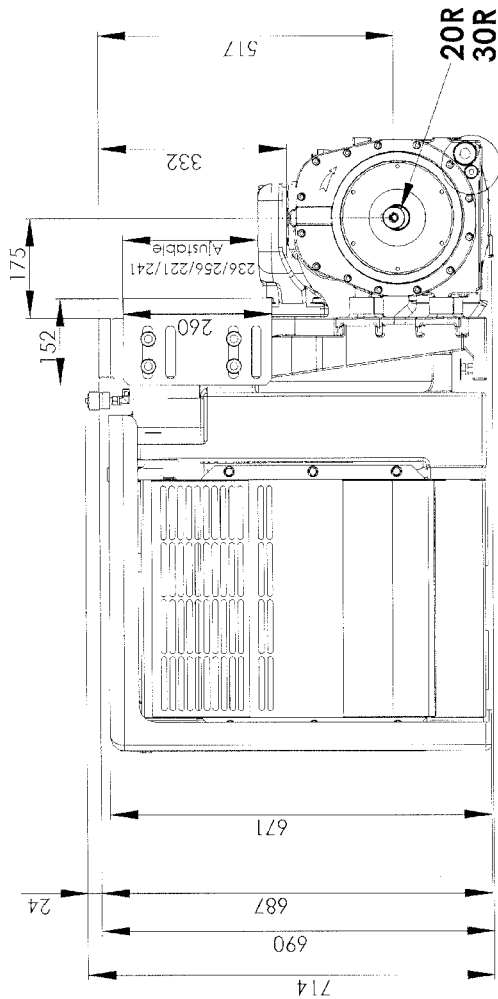

1. OVERALL DIMENSIONS (continued)

B600 13R/15L - 19R/22L DDIC

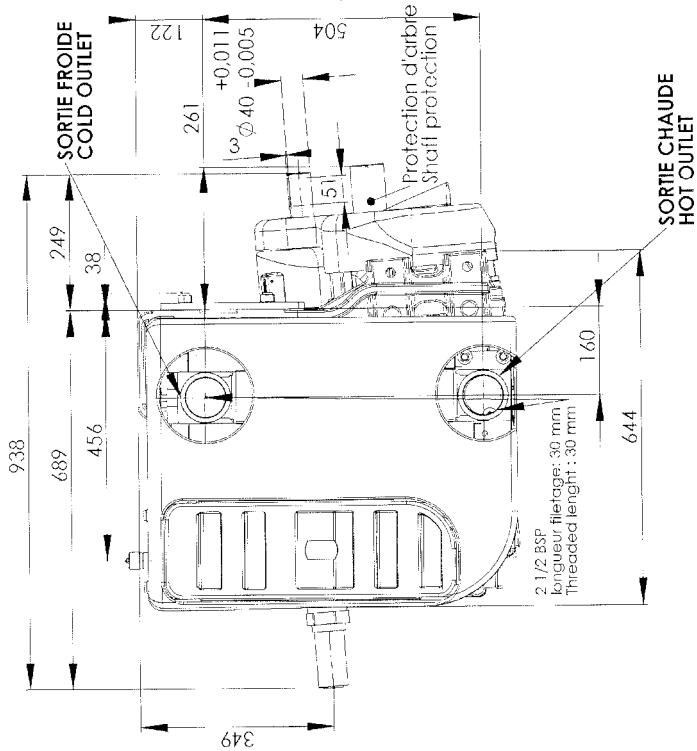

A	Jauge d'huile / Oil gauge
B	Filter à huile / Oil filter
C	Vidange / Draining cap
D	Contrôle pression refoulement G1/4" / Outlet pressure control G1/4"
E	Contrôle T° refoulement G1/4" / Outlet T° control G1/4"
F	Plaque signalétique / Identification plate
G	Prise pression huile / Oil pressure plug
H	Bouchon 3/4" (pour montage jauge d'huile à droite) / 3/4" cap for right oil gauge installation
J	Prise vitesse G1/4" / Speed control G1/4"
K	Contrôle pression aspiration G1/4" / Inlet pressure control G1/4"
L	Contrôle T° aspiration G1/4" / Inlet T° control G1/4"
M	Bouchon magnétique G3/8" / Magnetic plug G3/8"

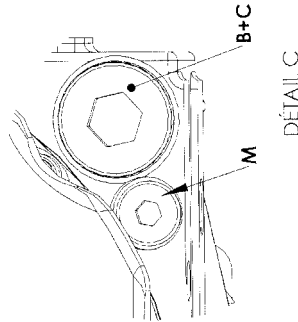

Poids avec limiteur de couple
Weight with torque limiter:
287 kg

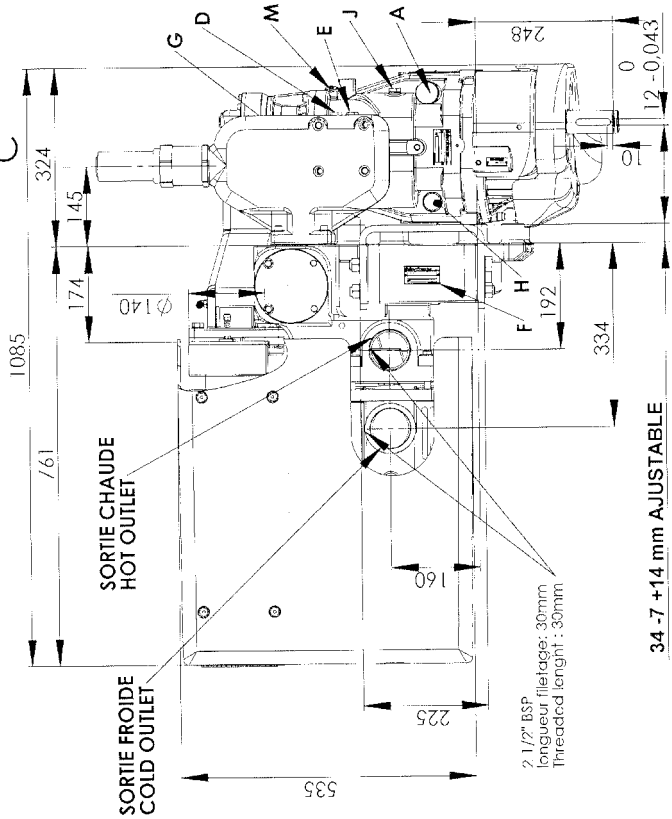
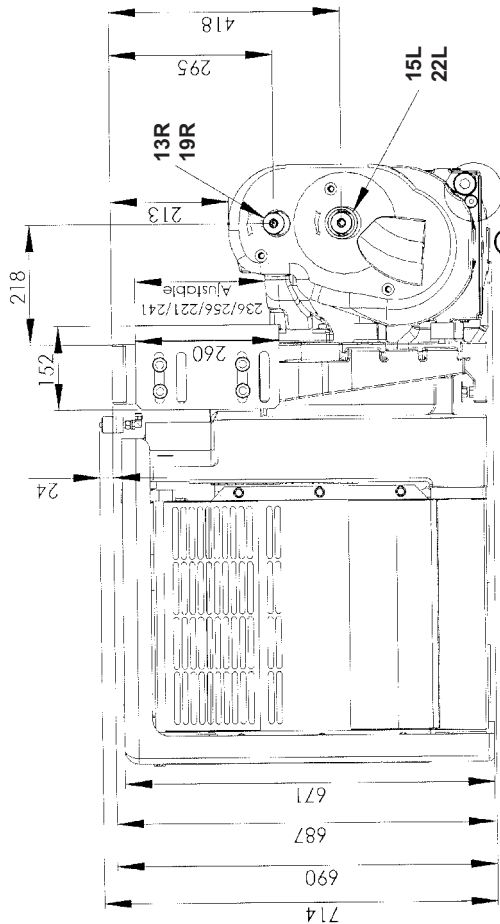

1. OVERALL DIMENSIONS (continued)

MISTRAL 20R - 30R DDIC

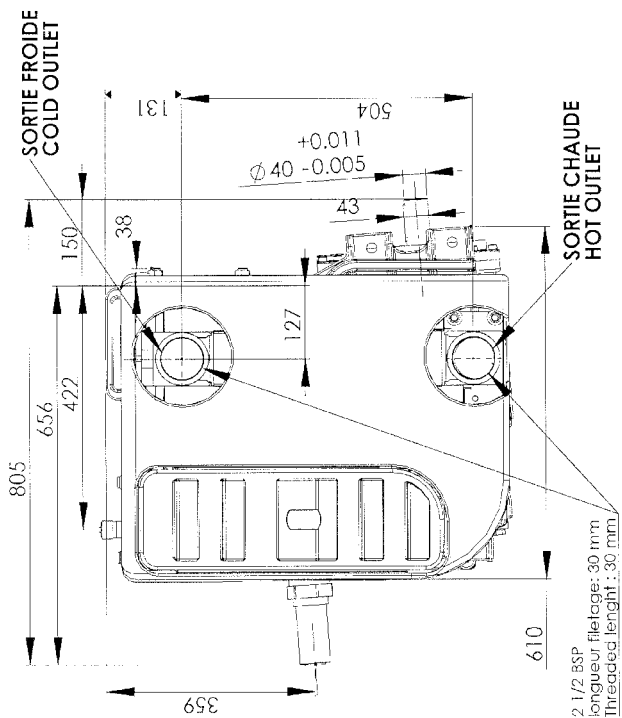

Poids avec limiteur de couple
Weight with torque limiter :
278 kg

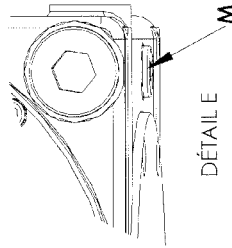

A	Jauge d'huile / Oil gauge
B	Filter à huile / Oil filter
C	Vidange / Draining cap
D	Contrôle pression refoulement G1/4"
E	Outlet pressure control G1/4"
F	Contrôle T° refoulement G1/4"
G	Outlet T° control G1/4"
H	Plaque signalétique / Identification plate
M	Prise pression huile G1/4" / Oil pressure plug G1/4" Bouchon 3/4" (pour montage jauge d'huile à droite) 3/4" cap for right oil gauge installation Bouchon magnétique G3/8" / Magnetic plug G3/8"

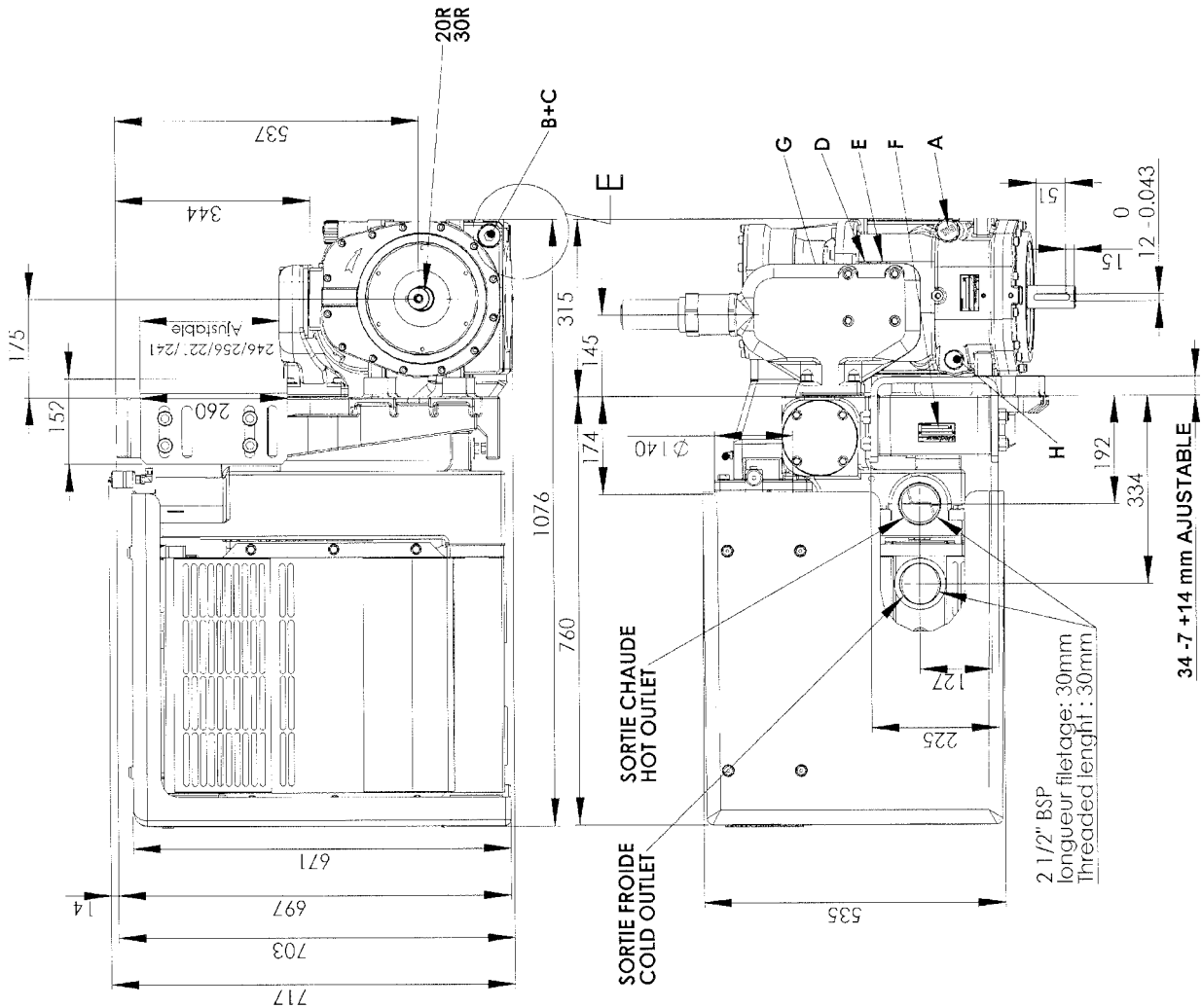

1. OVERALL DIMENSIONS (continued)

MISTRAL 13R/15L - 19R/22L DDIC

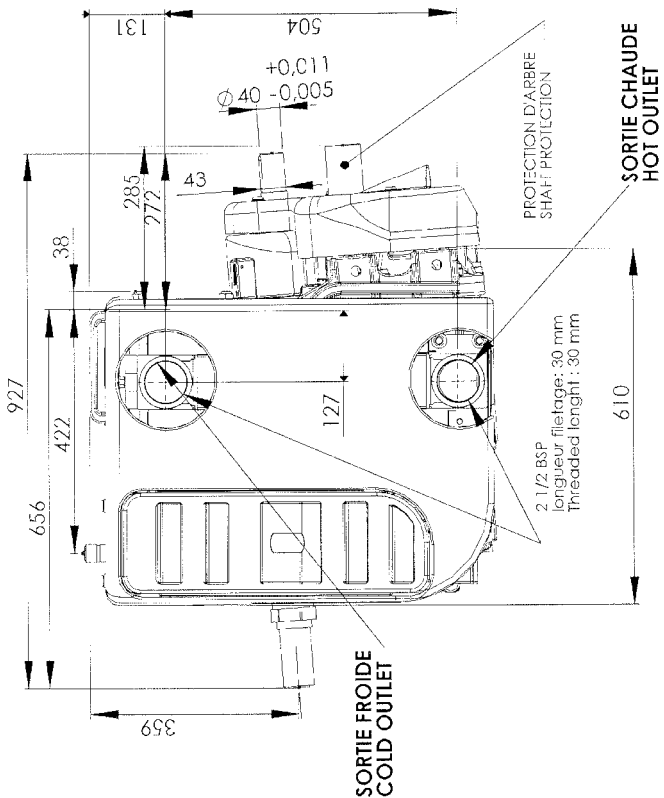

Poids avec limiteur de couple
Weight with torque limiter :
308 kg

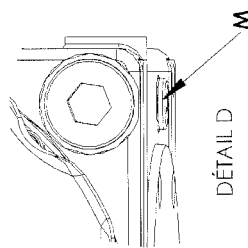

A	Jauge d'huile / Oil gauge
B	Filtre à huile / Oil filter
C	Vidange / Draining cap
D	Contrôle pression refoulement G1/4" Outlet pressure control G1/4"
E	Contrôle T° refoulement G1/4" Outlet T° control G1/4"
F	Plaque signalétique / Identification plate
G	Prise pression huile G1/4" / Oil pressure plug G1/4"
H	Bouchon 3/4" (pour montage jauge d'huile à droite) 3/4" cap for right oil gauge installation
M	Bouchon magnétique G3/8" / Magnetic plug G3/8"

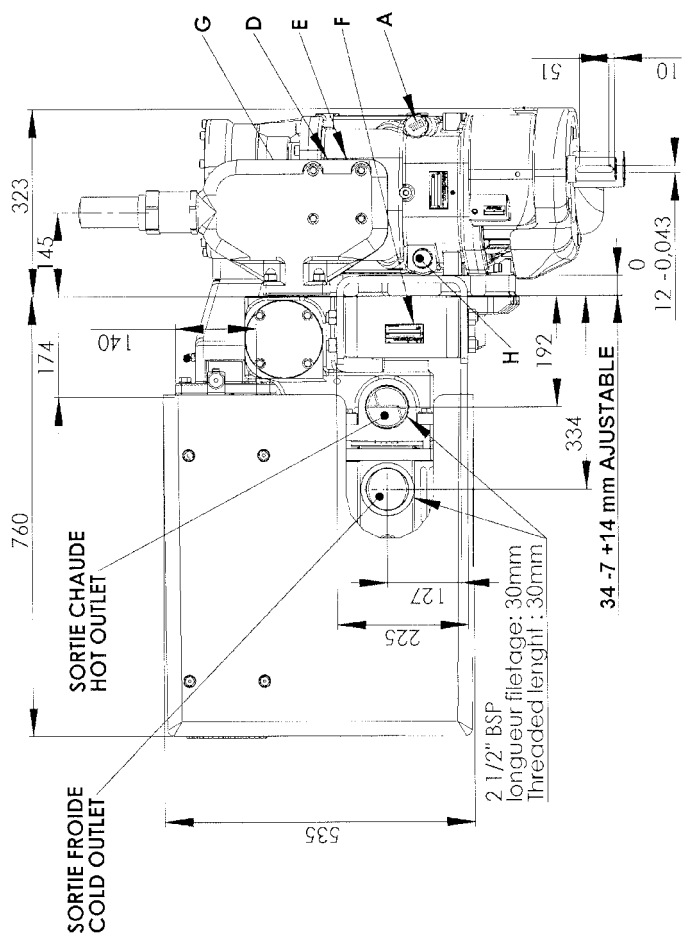
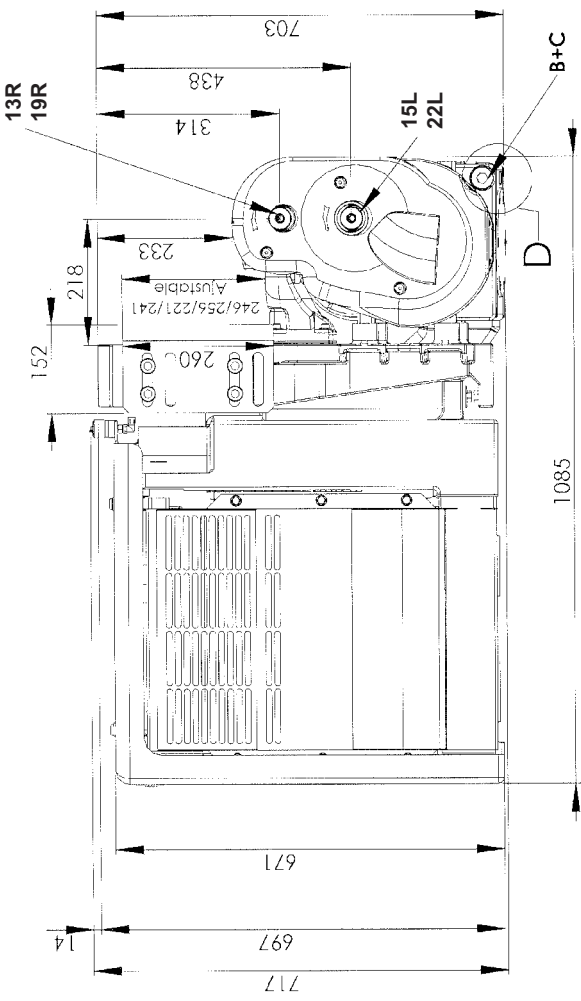

1. OVERALL DIMENSIONS (continued)

TYPHON II 20R - 30R DDIC

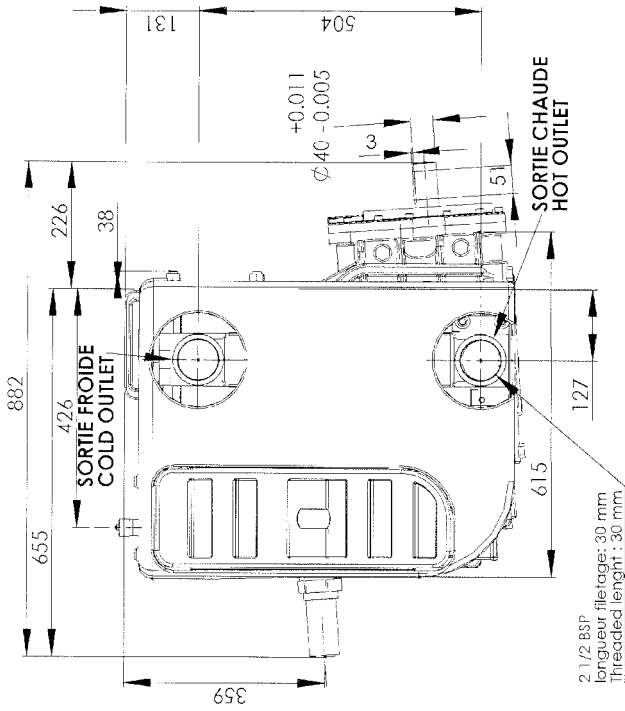

Poids avec limiteur de couple
Weight with torque limiter :
306 kg

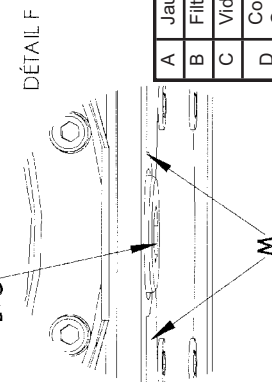

A	Jauge d'huile / Oil gauge
B	Filter à huile / Oil filter
C	Vidange / Draining cap
D	Contrôle pression refoulement G1/4" Outlet pressure control G1/4"
E	Contrôle T° refoulement G1/4" Outlet T° control G1/4"
F	Plaque signalétique / Identification plate
G	Prise pression huile / Oil pressure plug
H	Bouchon 3/4" (pour montage jauge d'huile à droite) 3/4" cap for right oil gauge installation
J	Prise vitesse G1/4" / Speed control G1/4"
K	Contrôle pression aspiration G1/4" Inlet pressure control G1/4"
L	Contrôle T° aspiration G1/4" / Inlet T° control G1/4"
M	Bouchon magnétique G3/8" / Magnetic plug G3/8"

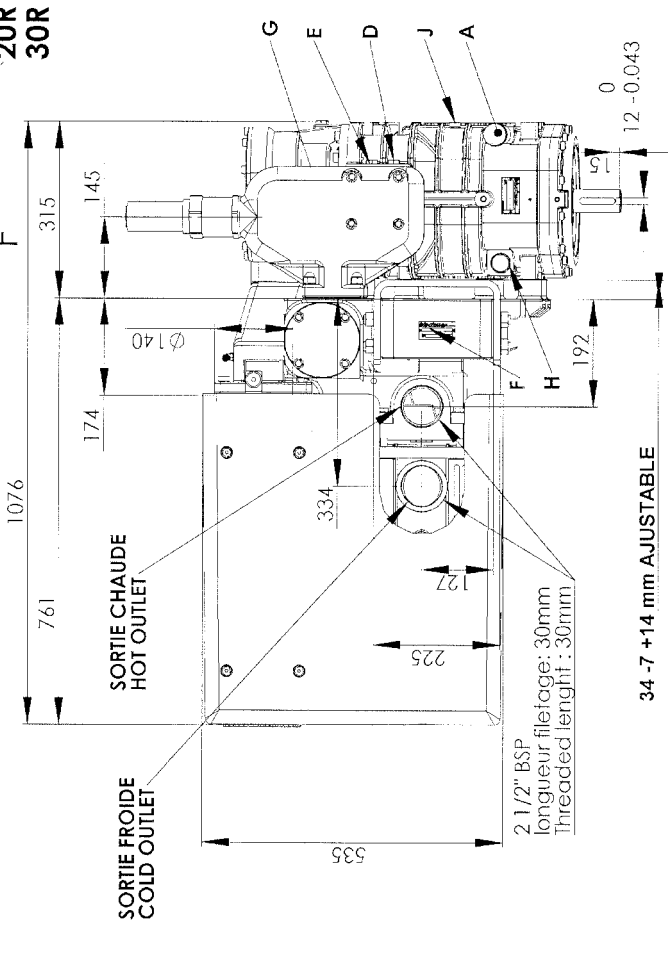
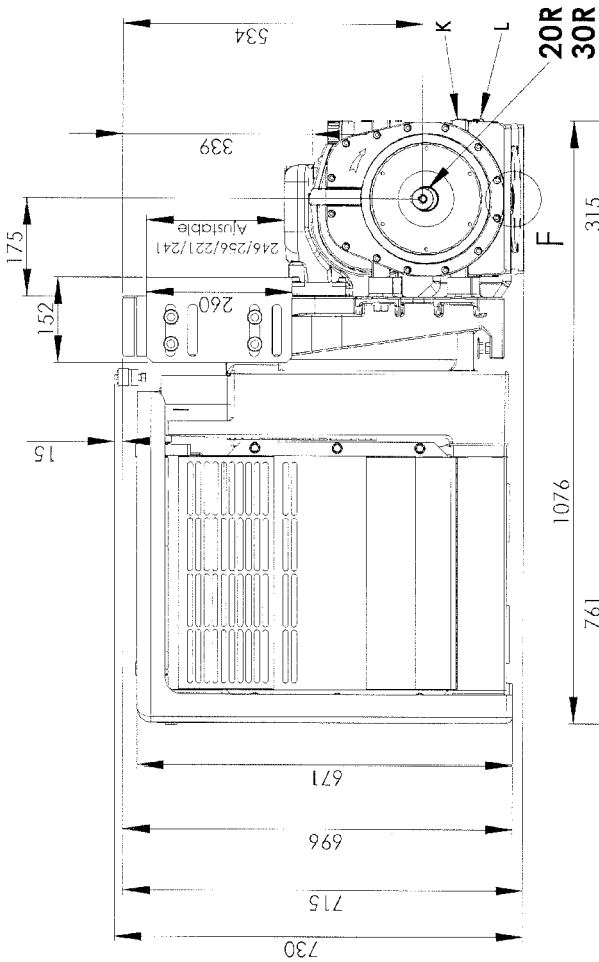

1. OVERALL DIMENSIONS (continued)

TYPHON II 13R/15L - 19R/22L DDIC

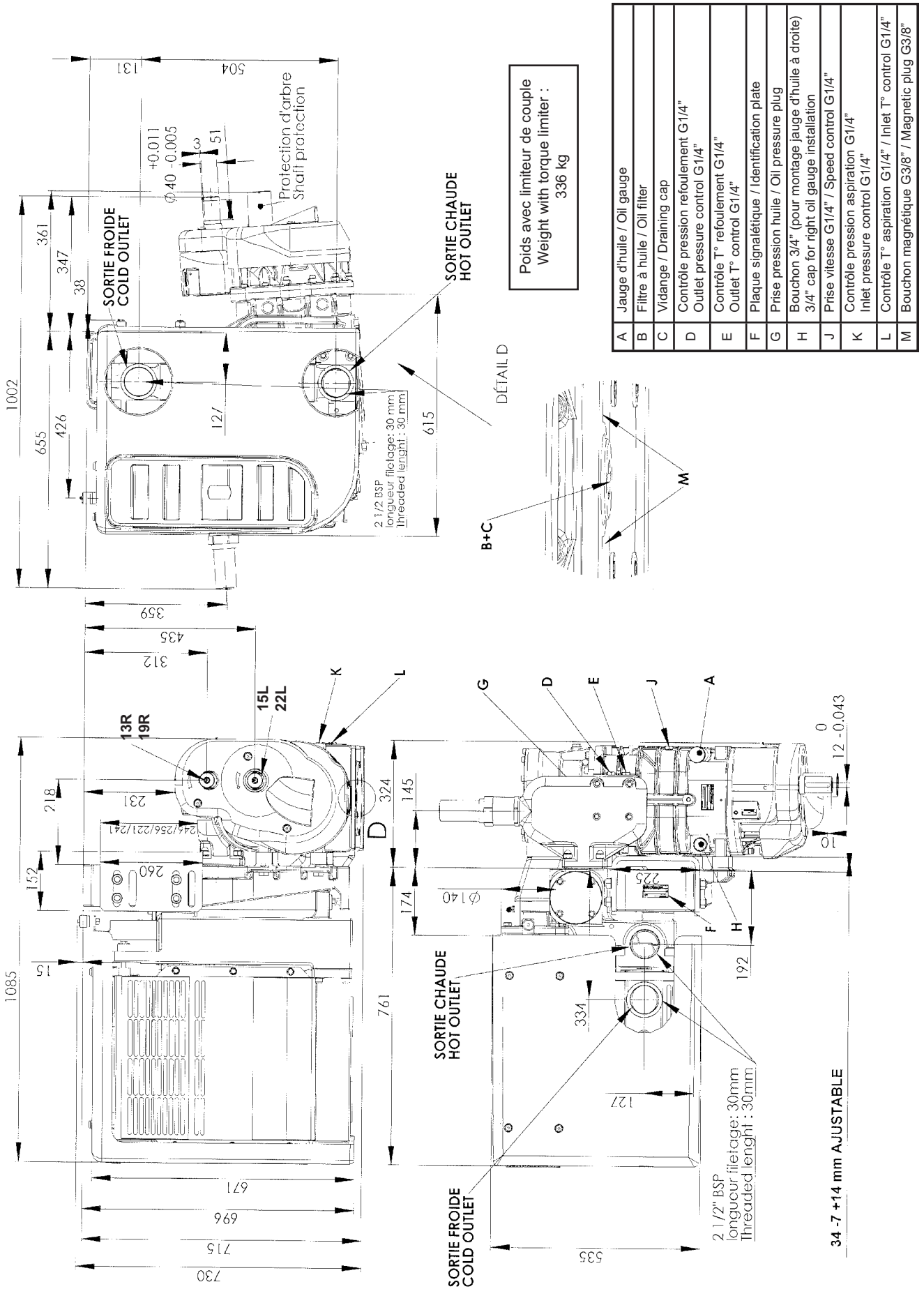

2. INSTALLATION

The screws used to :

- hold the compressor in place
- mount the filter flange
- mount the discharge flange

must be at least quality 12-9.

During the assembly, watch that no foreign body penetrates into the compressor. The piping of inhalation and expulsion must be perfectly clean. Any foreign body risks to damage seriously the compressor.



The presence of foreign bodies in the compressor inlet channel is susceptible of leading to serious property damage or serious injuries.

2.1 Mounting location

The compressor must be installed in a location where it is easily accessible. In particular, make sure that the oil filling plug, oil magnetic plugs and the filter are accessible.

The clogging indicator must remain visible to the operator.

Choose a location where the compressor is relatively protected from gravel projections and road spray as well as exhaust fumes and engine heat.

The compressor is mounted on the chair at an angle of 4°. If the chair is mounted vertically, it can be used to adapt to most movements, in other words those which have a gradient of between 3 and 5° inclusive.

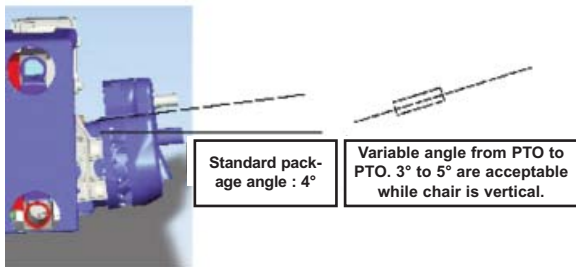

To prevent potential interferences between the package and the truck accessories (mudflap, tank...) a minimum distance of 5 cm between the package and these accessories must be respected.

To benefit fully from the cooling performance of DDIC packages, a minimum distance of 10cm must be respected between the right side of the package and any accessory forming an obstacle to air flow (tank...).

5 cm clearance to avoid any contact

10 cm clearance to optimize package outlet temperature

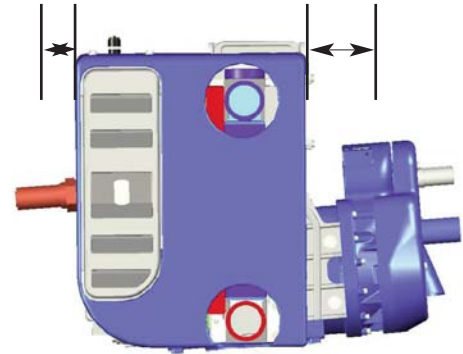

In the same way, a minimum distance of 5 cm must be respected between all accessories located in the chassis (PTO, universal joint...) and the compressor package.

2.2 Mounting procedure

2.2.1 Package handling procedure

Compressors are packaged and fixed onto a pallet. To move and install the package for the first time, the package should be carried on the pallet.

For maintenance operations, the package should be fastened onto a pallet such that the chair is vertical. The areas set aside for fastening the package are the compressor, silencer and inlet filter, as shown in the picture below.

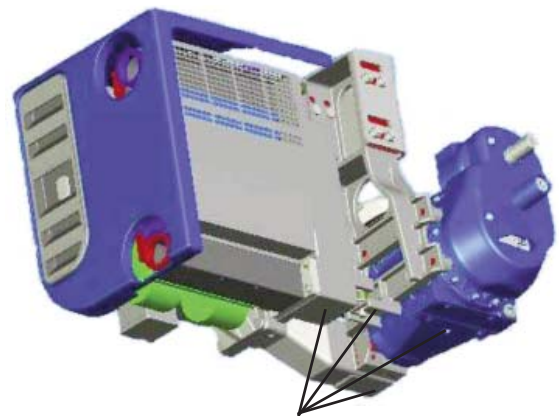

Those areas are acceptable to support the package. Compressor and chair support should be favored.

2. INSTALLATION (continued)

2.2.2 Package installation procedure

The compressor package is delivered with a special assembly tool. This U comes mounted on the chair. The U is not symmetrical, so that the installer has more room to move when choosing the vertical position of the package.

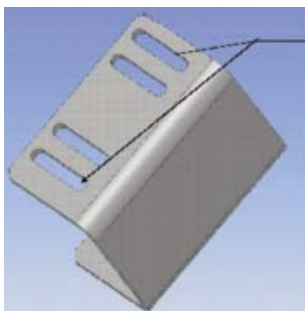

The openings are not symmetrical versus the U upper and lower sides

We propose the following assembly procedure:

- Bring the compressor package to the side of the truck using a transpallet or any other suitable equipment.
- Determine the position of the package on the truck as close as possible to its final position.
- Check the universal joint angles and how parallel the compressor shaft and the PTO shaft are
- Mark on the U the positions of the holes necessary for assembly.
- Remove the package from the truck
- Pierce the U, deburr and clean. To make sure that you do not make the part fragile keep a minimum axle spread distance of 40 mm between 2 holes.
- Use 6 screws Ø 14 mm minimum.
- Mount the U on the truck
- Bring the package to the truck
- Mount the package on the U with a minimum of 8 fixing points (4 on each side)

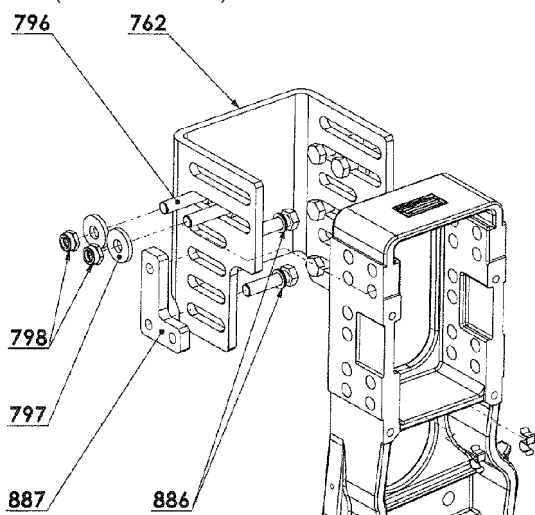

- Remove the pallet and package
- Check the universal joint angles and how parallel the compressor shaft and the PTO shaft are
- Mount the universal joint
- Perform an operating test on the compressor
- Check with a manometer the pressure at which the valve starts to open

2.3 At suction

It must be installed in such a way that the temperature of the air sucked in is equivalent to 5°C either side of ambient temperature.

Any side protection barriers must be removed EACH time the compressor is used to allow air to reach the compressor inlet freely, and move around the cooling circuit.

The installer must check whether there are such protective barriers and that they may be manipulated easily by the driver. It may be desirable to install a system preventing the operation of the PTO if the protection is not removed, to guarantee that the compressor operates under satisfactory conditions.

To prevent the filters from clogging prematurely, the air sucked in must be free of smoke and road dust.

A minimum distance of 300 mm must be left free in front of the filters for their extraction and replacement.

2.3.1 Standard suction

If using a standard package, no precautions need be taken when assembling the package.

2.3.2 Chimney suction

If using a chimney package, it will be delivered with a filter plugging plate instead of an in the location of the normal air feed plate.

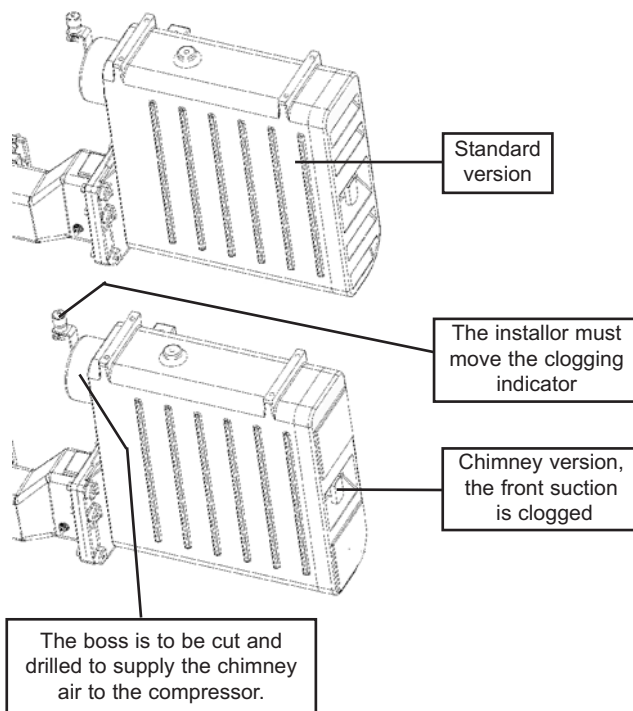

If this is the case, the air must be fed to the compressor from the rear of the filter box, on the boss, of diameter 140cm for the purpose.

2. INSTALLATION (continued)

NB The boss is not delivered pierced. The installer is responsible for piercing the aluminium on the inner passage assembly or cutting the edge of the boss. To prevent spillages during this operation from penetrating the compressor inlet channel, it is important to leave the filters in place during the assembly operation. The filter box will be cleaned and the filters will be replaced before the compressor is put into service.

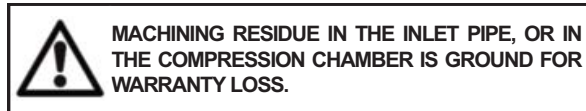

The installer is also responsible for mounting the filter clogging indicator somewhere visible to the truck driver under normal use of the compressor package.

2.4 Check relief / Safety valve

DDIC packages include a safety valve and a check valve.

The check valve is for preventing the return of particles from the tanker to the compressor, especially when the compressor is switched off, when the tanker is still pressurised.

The valve was adjusted prior to delivery. This adjustment is leaded.

Any valve manipulation will void the guarantee. Only MOUVEX personnel or authorised service centres are qualified to adjust the safety valves.

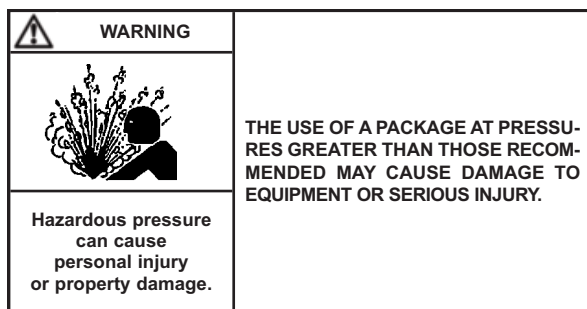

The maximum valve setting is 2.5 bar, but it must take into account the rotating speed range specified in the compressor instructions.

2.5 Drive

2.5.1 Speed range

In order to comply with the machine directive, the rotating parts of the compressor package (shafts, torque limiter, universal joint, PTO ...) must not be accessible to the user or the driver under normal conditions. If necessary, it is the installer's responsibility to fit the necessary protection for preventing any damage to equipment or physical injury.

MOUVEX cannot be held responsible for consequences due to the absence of such protection on the final installation.

The compressor may be operated directly by a universal joint shaft, with or without a multiplier.

The selection of the drive mode will take into account :

- The compressor mounting configuration
- The driving shaft rotation direction
- The expected power requirement for the given application
- The acceptable rpm range for the driving equipment
- The acceptable rpm range for the compressor.



The use of compressors outside of their operating speed range can lead to property damage or serious injuries. See Compressor instructions for more details.

IMPORTANT :

Any system providing for a compressor being driven by a thermal motor must include a system making it possible to disengage the compressor at startup and stop of the motor.

In all cases, the drive must make it possible :

- To maintain the compressor rotation speed during load variations (pressure variations) .
- Not to subject the compressor to sudden or insufficient starts.

2.5.2 PTO Shaft drive

It is mandatory to comply with the following instructions :

- The shaft must be dynamically balanced.
- Its length and its inclination must be as small as possible, see table
- The drive shaft slides perfectly well during rotation.
- The jaws of the universal joints are parallel.
- Coupling flanges show no eccentricity nor warping of the bearing surface.
- The angle formed by the universal joint and the drive shaft must not exceed 15°.
- The compressor shaft must be parallel to that of the drive shaft.
- The universal joint angle, as defined below, must be minimised.

2. INSTALLATION (continued)

DDIC packages incorporate a compressor gradient of 4° in relation to the horizontal. This gradient allows the recovery of the most recent PTO angles on current trucks. If your PTO angle is between 3 and 5° inclusive, you can install the chair vertically and respect operating recommendations.

If this is not the case, you should gently slope the chair to bring the angle between the compressor operating shaft and the PTO below 1°.

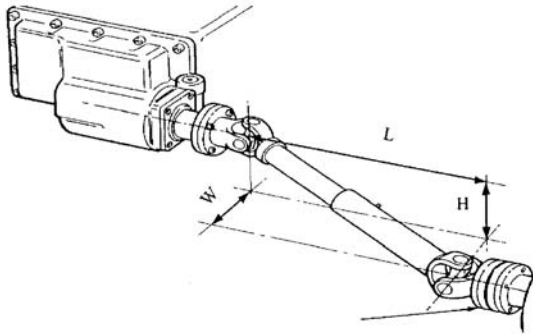

$$A = \frac{\sqrt{H^2 + W^2}}{L}$$

If H = Zero, A = W / L

If W = Zero, A = H / L

A	Universal joint angle	
0,017	1°	VERY GOOD
0,035	2°	
0,052	3°	
0,070	4°	
0,087	5°	
0,105	6°	GOOD
0,125	7°	
0,141	8°	
0,158	9°	
0,176	10°	LIMIT VALUES
0,194	11°	
0,213	12°	
0,231	13°	
0,249	14°	
0,268	15°	

It is possible to equip packages with a multiplier to lessen the universal joint angle. Refer to the compressor instructions for further information.

To protect the P.T.O in the event of compressor stalling, **it is necessary to install a torque limiter.** The MOUVEX company shall not be held responsible for damage resulting from such stalling if this stalling is caused by wrong manipulation with the compressor or if no or not the right torque limiter is installed.

The torque limiter will be installed on the compressor shaft, as illustrated in the photo below.

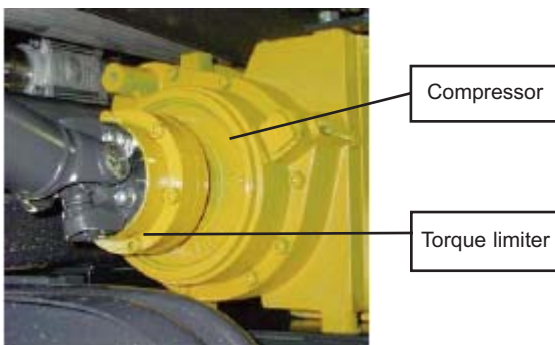

DDIC packages may be ordered with torque limiters mounted. Refer to Instructions 1401-B00 TORQUE LIMITER - MISTRAL B600 TYPHON II.



If the greasing instructions for the universal joint are not respected, this can lead to ruptures of this universal joint, as well as property damage and serious injuries.

2.5.3 Installation of channelling

Channelling connected to the package must be designed in accordance with regulations to prevent premature breakdowns on the installation.

In particular, MOUVEX recommends taking the following precautions:

- Channelling must be supported so as to prevent them from mechanically loading the inlets and outlets on the compressor package.
- Inlet and discharge channelling must have a diameter at least equal to that of inlet and discharge connections on the compressor package.
- At the inlet, you should limit sources of load loss (elbows, valves, lengths of channelling...).

2. INSTALLATION (continued)

2.6 Electric circuit

The DDIC packages require a power supply to run the cooler fan.

2.6.1 Electrical cabling suggested

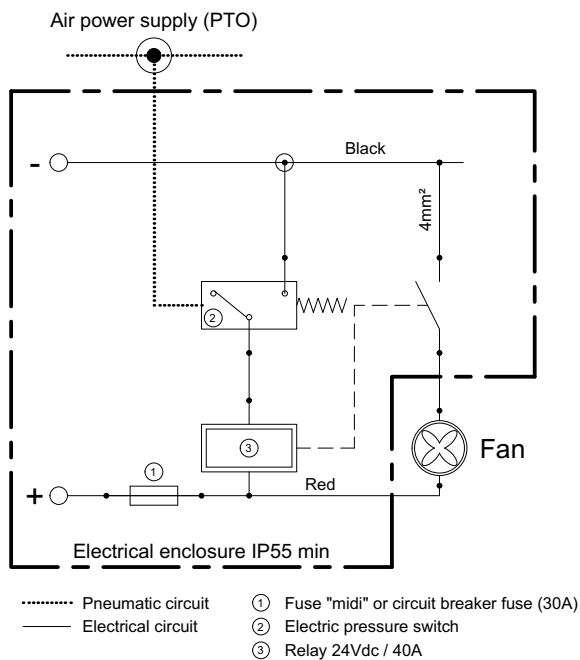

2.6.2 Connection procedure

Warning : The current source must be cut before any intervention in the electrical circuit to prevent any damage to equipment or physical injury.

The power supply for the package must be protected with a fuse (not supplied).

The electrical cable linking the compressor package to the power supply must be correctly supported to prevent its wear through friction, which could make the equipment live or cause unwanted microcuts.

The installer is responsible for supplying this electric line when the compressor is in use and switching it off when the compressor is not required.

To provide with power the fan use a relay. It could be controlled by a manual switch or automatic device that uses the command signal of the control drive.

Turning off the fan while the compressor is running can cause damage to equipment or physical injury (failure of the fan or accessories on the cooled outlet ...).

When it is first used, you should check that the air is blown by the fan through the cooler. If the air is sucked in by the fan through the cooler, have another look at the cabling.

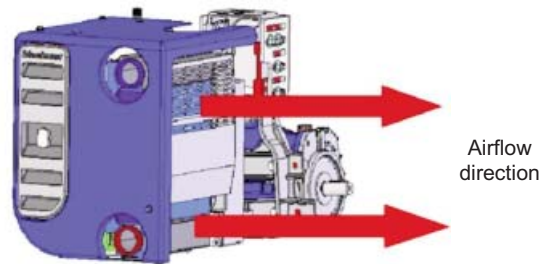

CAUTION :

Not respecting the direction of air circulation will lead to significant loss of cooler performance and fan reliability problems.

2.7 Instrumentation

The package is supplied with an inlet filter clogging indicator.

Any use of the compressor package when the indicator is showing excessive clogging will cause damage to equipment or physical injury.

Once the filters have been replaced, the clogging indicator can be reset to zero merely by rotating its cap.

2.8 Chair modification

No chair modification operation is permitted :

- Piercings
- Assembly operations
- Cutoff

risk of loss of MOUVEX warranty on the equipment.

3. USE

It is imperative to hold the hose in order to avoid whipping during pressurization.



The operator should remain nearby the equipment throughout the use to ensure the proper functioning of the system.

4. MAINTENANCE

4.1 Maintenance schedules

See the compressor instructions for the maintenance programme.

4.2 Air filter replacement procedure

Check weekly the clogging indicator. When it turns red, replace the filter cartridge.

Before installing a new cartridge, clean the internal part of the filter housing with a clean damp cloth.

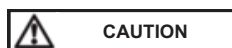

The presence of foreign bodies in the compressor inlet channel is susceptible of leading to serious property damage or serious injuries.

4.3 Cartridge replacement procedure

- Remove the wheel holding the filter cover
- Remove the filter cover
- Remove the screws holding the 3 round cartridges in place
- Remove the 3 round cartridges
- Throw away the old round cartridges
- Clean the area around the cartridge seal with a rag

- Place the cartridges on the supports in the following order :
 - Upper cartridge
 - Lower cartridge
 - Central cartridge
- Screw up the cartridges keeping the supports in a horizontal, centred position in relation to the sides of the filter box. The screwing will be done in the same order as that of the cartridge mounting.
- Replace the filter cover.
- By hand, rescrew the end wheel.

4.4 Drive train inspection

Periodically check that there is no play in the jaws and PTO cross pieces, turning the universal joint manually in one direction then in the other direction.

4.5 Check and relief valve inspection

See Instructions 1401-E00 MISTRAL - B600 - TYPHON II CHECK AND RELIEF VALVE.

5. WARRANTY

5.1 Warranty claims

The following part are considered as wear part :

- Inlet filter cartridge
- Compressor oil

No failure connected with wear part damage will be accepted under warranty conditions.

The following situations will void warranty for all components of the package :

- Tampering with the setting of the relief valve.
- Presence of foreign body inside the compressor body.
- Traces of damage representative of abnormal use of the package.
- Use of non genuine parts.
- If the compressor is repaired by a repairer who is not a MOUVEX-approved repairer.
- Construction of the package not validated by our Design Office.
- Use of an oil other than BSC for a 13R/15L and 19R/22L compressor.

Before returning your equipment to the factory, you must first obtain an Equipment return approval (RMA) from our After Sales Department.

A Compressors form information shall be filled by the installer or distributor and send to MOUVEX in order to claim for a warranty.

5.2 24-months warranty extension with BSC3 oil

The 24-months warranty extension with BSC3 oil option increases the warranty for the screw compressor to 60 months :

- Europe zone only,
- Only concerns the bare shaft compressor with or without multiplier, excluding packages and accessories (air filter, torque limiter, check relief valve...),
- Use of BSC3 oil (provide invoices),
- Conditions identical to the current standard warranty.

6. TROUBLESHOOTING

CAUTION :
OBSERVE ALL SAFETY WARNINGS CONTAINED IN THIS MANUAL.

Problem	Possible origin	Possible solution
1. Pressure issue	Too much pressure drop.	To check pipes diameter.
	Relief valve damaged.	To check the opening point.
	No return valve damaged.	To check the proper operating of the No return valve.
2. Flow rate issue	Wrong Compressor speed.	To adjust the speed by taking care of the range allowed.
	Relief valve damaged.	To check the opening point.
3. Abnormal high temperature	Air filter clogged.	To clean the cartridge or to replace it.
	Air pressure too much high.	To see problems 1. / 2.
	Outside temperature too much high.	To respect the maximum external temperature allowed.
	Lack of oil.	To check the oil level.
	Compressor speed too much low.	To adjust the speed by taking care of the range allowed.
4. Inlet pressure drop > 75 mbar (clogging indicator red)	Air filter clogged.	To clean the cartridge or to replace it.
	Air inlet hose folded.	To check the air inlet hose.
5. Compressor doesn't operate	Torque limiter damaged.	To replace the torque limiter.
	Transmission damaged.	To consult your Service point.
6. Torque limiter damaged	Screw Compressor damaged.	To consult your Service point.
	Wrong motor / transmission management.	To consult your Truck dealer.
	Oil too much viscous.	To be in compliance with the MOUVEX Instructions.
7. Oil leak	Too much oil.	To check the oil level.
	Oil breather clogged.	To clean the oil breather.
8. Vibrations	Wrong motor speed.	To increase the speed by taking care of the range allowed.
	Transmission damaged.	To check the driving shaft.
	Lack of rigidity of the chassis.	To be in compliance with the Truck Manufacturer Instructions.

7. STORAGE CONDITIONS

7.1 Compressor

The equipment must be systematically stored in an area sheltered from bad weather.

The equipment must bear its original protective components until it is installed in its final application.

If installation is interrupted, put back in place the original protective components or equivalent components.

7.2 BSC oil

In its unopened original container in a dry, frost-free and light-free place.

The maximum shelf life is approx. 60 months.



8. SCRAPPING

The compressor must be scrapped in compliance with the regulations in force.

During this operation, particular care must be paid to the drainage stages of the compressor.

9. COMPRESSORS FORM INFORMATION

Before any material return, it is required to get an authorization from MOUVEX.

 <p style="text-align: center;"><i>After Sales Department</i></p> <p style="font-size: small;">Z.I. La Plaine des Isles - 2 rue des Caillottes - 89000 AUXERRE - FRANCE ☎ +33 3 86 49 87 25 - mouvex.customersupport@psdover.com</p>	<h2 style="margin: 0;">COMPRESSORS FORM INFORMATION</h2>	
In order to treat correctly the warranty claims, please first complete this information form. Thanks to return us this completed document by email as soon as possible.		
NAME, ADDRESS AND PHONE NUMBER OF THE CUSTOMER		
<p><u>Material purchased by :</u></p> <p>.....</p> <p>.....</p> <p>.....</p>	<p><u>Material mounted by :</u></p> <p>.....</p> <p>.....</p> <p>.....</p>	<p><u>Material used by :</u></p> <p>.....</p> <p>.....</p> <p>☛ Person to contact for technical information :</p> <p>☎</p>
EQUIPMENT CONCERNED		
<input type="checkbox"/> Screw compressor <input type="checkbox"/> Vane compressor Type : Delivery date : Starting-up date : Serial N° : Running time estimation (hours) : Have you already replaced the equipment by a new one ? <input type="checkbox"/> Yes <input type="checkbox"/> No ☛ If yes, indicate its serial N° :		
<p style="text-align: center; background-color: #cccccc; margin: 0;">TYPE OF INSTALLATION</p> <input type="checkbox"/> Direct PTO drive <input type="checkbox"/> Belt drive system <input type="checkbox"/> Torque limiter (value) : <input type="checkbox"/> Pressure relief valve setting (value) : <input type="checkbox"/> Package DDNC <input type="checkbox"/> Package DDIC <input type="checkbox"/> Other (electric, diesel or hydraulic motor) ☛ Brief description : <i>(please join a drawing or pictures of the installation)</i>	<p style="text-align: center; background-color: #cccccc; margin: 0;">OPERATING PARAMETERS</p> ☛ Compressor's speed : rpm ☛ Operating pressure : bar ☛ Motor speed at the time of the incident : rpm ☛ PTO ratio : ☛ Product transferred :	
<p style="text-align: center; background-color: #cccccc; margin: 0;">DESCRIPTION OF THE MATTER</p> <input type="checkbox"/> Leakage <input type="checkbox"/> Insufficient flow <input type="checkbox"/> Insufficient pressure <input type="checkbox"/> Blocking <input type="checkbox"/> Noise / vibration <input type="checkbox"/> Other :		
 IN CASE OF RETURN OF MATERIAL TO OUR FACTORY, PLEASE REQUEST IMPERATIVELY BEFORE SENDING THE MATERIAL RETURN AUTHORIZATION (RMA) WHICH WILL BE PROVIDED TO YOU BY MOUVEX AFTER SALES DEPARTMENT.		

rev.10/06/2020