



Instructions 1401-AL00 (En)

Section	1401
Effective	June 2026
Replaces	October 2024

Original instructions

MX12 SCREW COMPRESSORS



**INSTALLATION
OPERATION
MAINTENANCE
SAFETY
STORAGE**



**This Instructions only contains bare shaft machine information.
It is imperative to have in complement the accessories instructions, also the parts list before installing the equipment.**

EC CERTIFICATE OF CONFORMITY :

The EC Certificate of Conformity (paper version) is systematically attached to the equipment when shipped.

WARRANTY :

MX12 screw compressors are covered 24 months by warranty within the limits mentioned in our General Sales Conditions. The use of the BSC3 oil carries our warranty from 24 to 36 months. In case of a use other than that mentioned in the Instructions manual, and without preliminary agreement of MOUVEX, warranty will be canceled.

Warranty extension with oil BSC3 : See § WARRANTY.



Z.I. La Plaine des Isles - F 89000 AUXERRE - FRANCE
Tel. : +33 (0)3.86.49.86.30
contact.mouvex@psgdover.com - www.mouvex.com

Your distributor :

MOUVEX TRUCK SCREW COMPRESSOR

SAFETY, OPERATION AND MAINTENANCE INSTRUCTIONS

MODEL : MX12

Definition of safety symbols



This is a SAFETY ALERT SYMBOL.

When you see this symbol on the product, or in the manual, look for one of the following signal words and be alert to the potential for personal injury, death or major property damage.



Warns of hazards that **WILL** cause serious personal injury, death or major property damage.



Warns of hazards that **CAN** cause serious personal injury, death or major property damage.



Warns of hazards that **CAN** cause personal injury or property damage.

NOTICE

Indicates special instructions which are very important and must be followed.

REMARKS :

MOUVEX truck screw-type compressors **MUST** be installed in systems designed by qualified personnel. The installation **MUST** be in compliance with local standards, national regulations and rules of safety.

This manual is designed to permit installation and commissioning of MOUVEX truck screw-type compressors and MUST accompany the compressor.

Maintenance of MOUVEX screw-type compressors must ONLY be carried out by qualified technicians. This maintenance must meet local and national standards as well as all safety regulations. Read this manual, including all instructions and warnings, in full BEFORE any use of MOUVEX compressors.

Do not remove the warning and use label stickers that are found on the compressors.

TABLE OF CONTENTS

Page













1. GENERAL DATA	4
1.1 Principle of operation	4
1.2 Technical characteristics	4
1.3 Operating ranges	5
2. INSTALLATION	6
2.1 Mounting location	6
2.2 Fixations	6
2.3 Connections	7
2.4 At suction	8
2.5 Discharge	8
2.6 Drive	8
2.7 Oil cooler	10
3. USE OF COMPRESSOR	12
3.1 Lubricant recommendations	12
3.2 Filling of lubricant	12
3.3 Operation	13
3.4 Starting-up	13
4. MAINTENANCE	14
4.1 Maintenance schedules	14
4.2 Compressor oil change procedure	14
4.3 Air filter replacement procedure	14
4.4 Drive train inspection	14
4.5 Check valve and relief valve inspection	14
5. TROUBLESHOOTING	15
6. WARRANTY	16
6.1 Warranty claims	16
6.2 24-months warranty extension with BSC3 oil	16
7. STORAGE CONDITIONS	16
7.1 Compressor	16
7.2 BSC oil	16
8. SCRAPPING	16
9. OVERALL DIMENSIONS	17

ADDITIONAL DOCUMENTATION

The table below gives the list of instructions in addition to this central instruction :

MX12 Application	Instructions	Parts list
MX12 DDIC	NT 1401-AP00	PL 1401-AP01
MX12 PTO selection	NT 1401-AM00	-
Torque limiter	NT 1401-B00	PL 1401-AL01
Check and relief valve	NT 1401-E00	PL 1401-AL01
Air cooler	NT 1401-AJ00	-

SAFETY DATA

 <p>WARNING</p>	
	
<p>Hazardous machinery can cause severe personal injury or property damage.</p>	<p>IT IS IMPERATIVE TO APPLY THE TRUCK PARKING BRAKE AND TO BLOCK THE WHEELS BEFORE ANY INTERVENTION DUE TO RISKS OF SERIOUS BODILY INJURIES OR PROPERTY DAMAGE.</p>
 <p>WARNING</p>	
	
<p>Hazardous fluids can cause fire, serious personal injury or property damage.</p>	<p>COMPRESSING GASES INTO A VESSEL CONTAINING FLAMMABLE OR EXPLOSIVE GASES OR COMPRESSING FLAMMABLE OR EXPLOSIVE GASES, CAN CAUSE PROPERTY DAMAGE, PERSONAL INJURY OR DEATH.</p>
 <p>WARNING</p>	
	
<p>Hazardous pressure can cause personal injury or property damage.</p>	<p>FAILURE TO INSTALL ADEQUATELY SIZED PRESSURE RELIEF VALVE(S) CAN CAUSE PROPERTY DAMAGE, PERSONAL INJURY OR DEATH.</p>
 <p>CAUTION</p>	
	
<p>Extreme heat can cause injury or property damage.</p>	<p>COMPRESSOR, PIPING AND ACCESSORIES WILL BECOME HOT DURING OPERATION AND CAN CAUSE SERIOUS PERSONAL INJURY.</p>
 <p>WARNING</p>	
	
<p>Hazardous or toxic fluids can cause serious injury.</p>	<p>CONTENTS OF THE COMPRESSOR, TANK, PIPING, AND FILTERS COULD BE HAZARDOUS TO HEALTH. TAKE ALL NECESSARY PRECAUTIONS WHEN PERFORMING COMPRESSOR SERVICE OR MAINTENANCE.</p>
 <p>WARNING</p>	
	
<p>A loud noise can cause permanent body damage.</p>	<p>THE NOISE EMITTED BY WORKING MOVEX SCREW COMPRESSOR CAN BE HIGHER THAN 80 DBA. THE END USERS MUST USE, WHEN NECESSARY THE APPROPRIATE EAR PROTECTIONS. FAILURE TO WEAR HEAR PROTECTIONS IN AREAS WHERE THE NOISE IS HIGHER THAN 80 DBA CAN LEAD TO PERMANENT BODY DAMAGE.</p>

SAFETY CHECK LIST

1. Before operating the compressor, ensure the vessel to which the compressor is connected is certified to withstand the pressure.
2. Verify adequately sized relief valves have been fitted to protect the vessel. Do not use solvents or inflammable products for cleaning the pipelines and the accessories.
3. Gas/air mixtures which are potentially volatile/explosive must not be introduced or allowed to be introduced into the compressor.
4. All pressure vessel and piping connected to the compressor must be isolated and in a safe operating condition.
5. Operators should wear ear protection when operating truck mounted compressors.
6. There are components within the compressor of sufficient weight to cause injury if mishandled. Use proper lifting devices as necessary.
7. Where necessary, this equipment should be grounded to control static electricity.
8. The temperature of the air leaving the compressor is elevated above ambient due to air compression. Check that the elevated temperatures do not adversely affect the product and any material used in design of the system. Attach clearly marked warning signs to warn of potentially hot surfaces on the compressor, piping and accessories which will burn if touched.
9. Mounting of the compressor must be correctly engineered and the compressor must be properly secured. Refer to the Compressor Mounting section of this manual.

NOTICE :

MOVEX COMPRESSORS ARE DESIGNED TO PRODUCE COMPRESSED AIR. NOT TO PUMP LIQUIDS, LIQUEFIED GASSES OR POWDERS THOUGH THE COMPRESSOR. TO DO SO WOULD VOID THE WARRANTY.

LIFTING POINTS :

To connect 1 lifting ring to the item (1) alone or 2 lifting rings to the items (1) + (2).

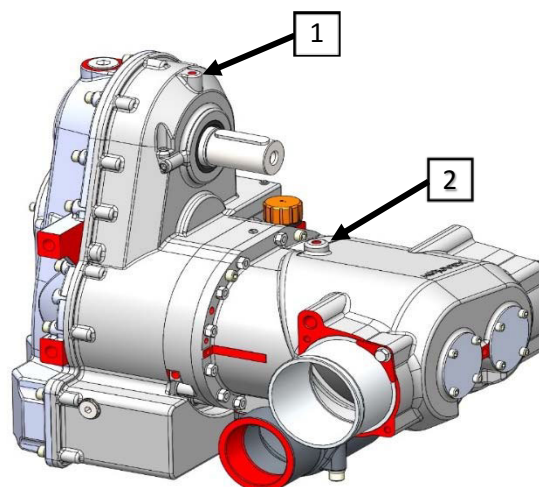

1. GENERAL DATA

1.1 Principle of operation

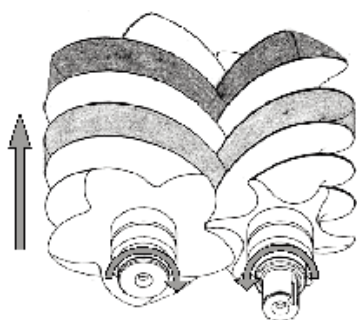

The male screw and the female screw mesh and rotate in opposite directions inside the casing fitted with inlet and discharge ports.

Rotation generates a volume increase on the inner face between threads and grooves, which corresponds to inlet, and a volume reduction on the upper face, which corresponds to compression.

On the discharge port side, a set of gears synchronizes the male screw and the female screw. Thus, the screws are not in contact. The discharged air does not enter in contact with any friction part and remains clean and free from particles.

On the drive shaft side, the female screw is driven by a set of step-up gears.

An oil pump delivers pressurized oil which circulates, lubricating gears and ball bearings.

Sealing is provided between lubricated parts and the compression stage by means of labyrinth seals. These seals do not enter in contact with the shaft and are not subject to wear.

Thanks to their technology, MX12 compressors are reliable and have a long service life.

MX12 compressors need very limited maintenance, which reduce vehicle downtime.

MX12 version S drive speed were defined so as to drive it directly through universal joints from a P.T.O. shaft. MX12 compressor is therefore fitted within the chassis. Thanks to this system, the installation is lighter and saves space on the side of the vehicle for other accessories.

MX12 version N can be directly driven by an electric, hydraulic or diesel motor.

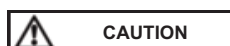

Our compressors are delivered without oil. The use of a compressor with an incorrect oil level can lead to important property damage and serious injuries.

1.2 Technical characteristics

The operating characteristics are given in the indicative operation conditions : ambient temperature and air inlet temperature 20°C, atmospheric pressure : 1013 mbars.

Speed allowed at the compressor drive shaft : See § OPERATING RANGES - RECOMMENDED DRIVE CONDITIONS.

Rotation direction :

Version	S	N
15	R	L
18	L	R
20	R	L
24	L	R

N version

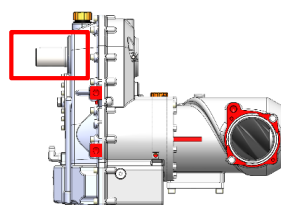

S version

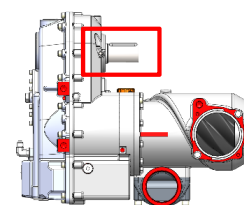

1. GENERAL DATA (continued)

1.3 Operating ranges

The operating ranges specified in the § TECHNICAL CHARACTERISTICS give the conditions that must be respected on mounting and packaging of the MX12.

1.3.1 CONDITIONS AT SUCTION

In all cases of use, the compressor inlet suction air must be filtered in order to eliminate particles bigger than 5 µm.

Compressor functioning under pressure :

The maximum pressure drop at suction must be lower than 75 mbar.

A clogging indicator device turns red when the filter needs to be changed.

REMINDER :

THE CLOGGING INDICATOR MUST NOT BE RED WHEN THE COMPRESSOR IS IN PRESSURE OPERATION.

1.3.2 CONDITIONS AT DISCHARGE

The MX12 compressor must be protected by a valve that protects the compressor against accidental over-pressure.

See Instructions 1401-E00 SCREW COMPRESSORS CHECK AND RELIEF VALVE.

Maximum acceptable discharge pressure : see curve below.



Having the compressor run above its maximal pressure may lead to serious body injuries or property damages.

1.3.3 RECOMMENDED DRIVE CONDITIONS

Operating torque at full speed (Nm)

Version	1 bar	1,5 bar	2 bar	2,5 bar
15	300	350	420	490
18	250	295	350	410
20	225	265	310	370
24	190	220	260	310

Characteristics of bare shaft end compressor :

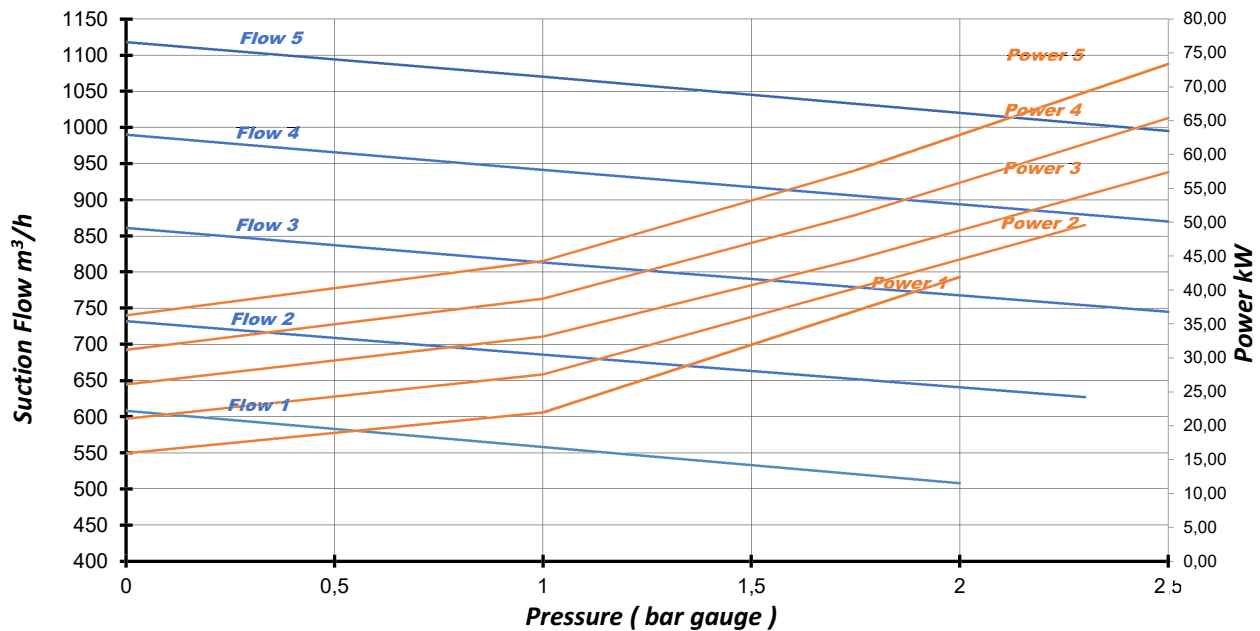

Version	Curve number and corresponding speed in rpm				
	1	2	3	4	5
15	862	1006	1151	1296	1439
18	1034	1208	1382	1556	1727
20	1150	1343	1536	1730	1920
24	1377	1608	1840	2072	2300

2. INSTALLATION

During the assembly, check that no foreign body penetrates into the compressor. The piping inlet and outlet must be perfectly clean.

Any foreign body risks to damage seriously the compressor.

All the fixation points availables must be used.



The presence of foreign bodies in the compressor inlet channel is susceptible of leading to serious property damage or serious injuries.

2.1 Mounting location

The compressor must be installed in a location where it is easily accessible. In particular, check that the oil filling plug, the magnetic plugs and the filter are accessible.

Choose a location where the compressor is relatively protected from gravel projections and road spray as well as exhaust fumes and engine heat. When the compressor is directly driven by universal joints, it will be installed between the chassis side members. In other cases, it can be installed either between the side members or beside the chassis side. The compressor may be installed with a small angle, but please ensure not to exceed the angular values set out in the diagrams below.

If the compressor is to be painted, use high temperature resistant paint.

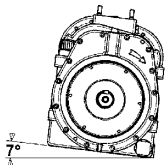
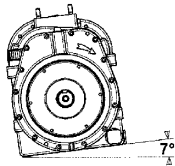
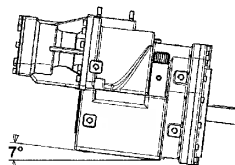
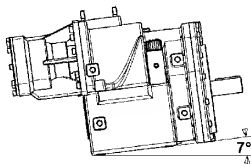

IMPORTANT

During operation, the temperature of the surface of a compressor and nearby parts can be in the region of 200°C.

The compressor and the parts located nearby are thus susceptible of provoking serious burns and property damage.

Be careful to not approach elements that are sensitive to heat and affix plates informing users that the compressor is hot, to prevent any risk of burns.

2.2 Fixations

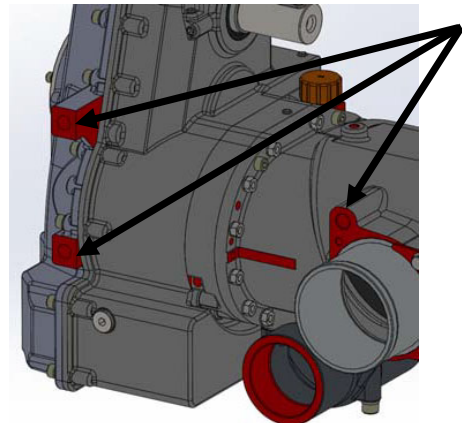

2.2.1 Install lateral plate

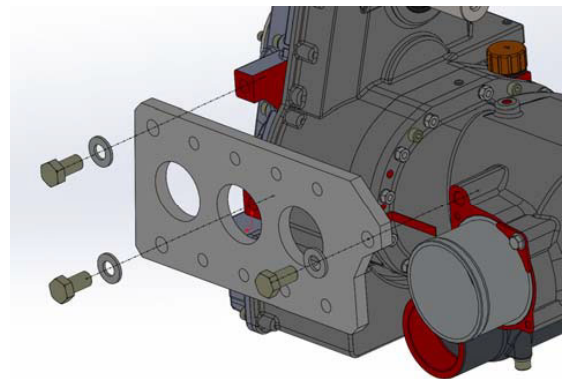

2.2.2 Install U

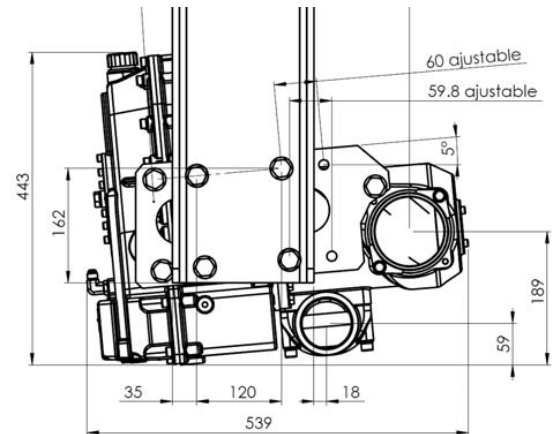

NOTA :

The compressor must be fixed on one side or the other using the 3 bosses.

The 3 ØM16 threads must be free of grease, paint, oxidation, etc. Retap if necessary.

Use quality 8.8 screws fitted with Nord-Lock type steel washers.

The screws which must have an implantation of ~ 20 mm in the threads must be tightened to a torque of 120 Nm using a torque wrench.

Finally, make sure that the side plate is perfectly clamped, meaning that the screws are not against the bottom of the threads.

2. INSTALLATION (continued)

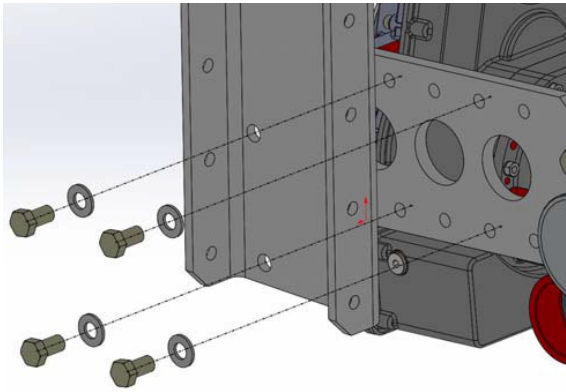

The length of this U is too high on purpose (to cover any brand for the beginning of this project).

- Bring the compressor to the side of the truck using a transpallet or any other suitable equipment.
- Determine the position of the package on the truck as close as possible to its final position.
- Check the universal joint angles and how parallel the compressor shaft and the PTO shaft are.
- Mark on the chair the positions of the holes necessary for assembly.
- Remove the package from the truck.
- Pierce the chair, deburr and clean. To make sure that you do not make the part fragile keep a minimum axle spread distance of 40 mm between 2 holes.
- Bring the package to the truck.
- Mount the package on the chassis with a minimum of 6 fixing points (M14 quality 12-9).
- Remove the pallet and package.
- Check the universal joint angles and how parallel the compressor shaft and the PTO shaft are.
- Mount the universal joint.
- Perform an operating test on the compressor.
- Check with a manometer the pressure at which the valve starts to open.

2.3 Connections

2.3.1 Oil cooler

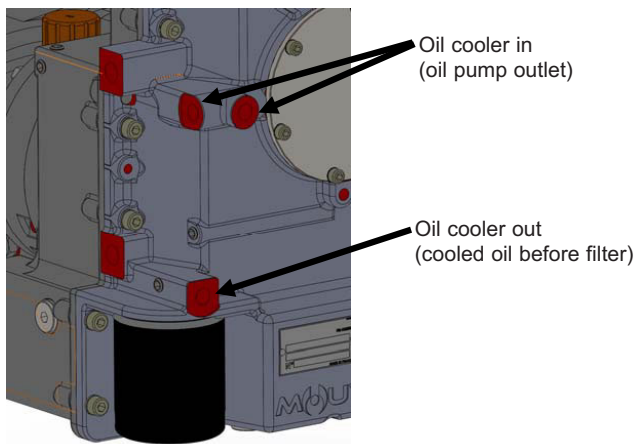

2.3.2 Breather

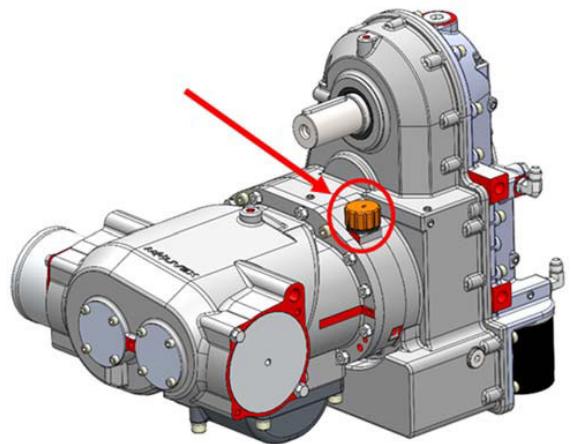

2.3.3 Inlet

It uses the same parts than MH6.

There are 2 positions possible: left or right.

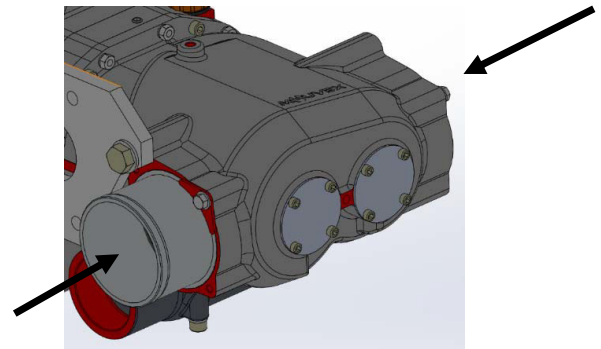

Closed

Inlet



2.3.4 Outlet

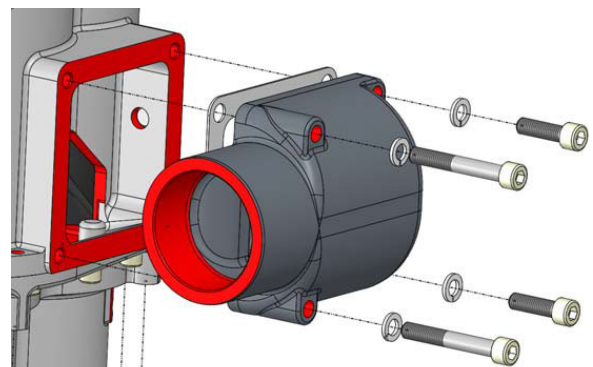

It is square so several positions are possible.

2. INSTALLATION (continued)

2.4 At suction

The suction side of the compressor must be fitted with a air filter. This filter must be installed horizontally, rain protection cap upwards. It must be positioned to avoid gravel projections and road spray as well as exhaust fumes and engine heat.

The air filter is connected to the compressor by a hose. Before making this connection, which must be perfectly sealed, make sure that the inlet pipe and attachment flanges are clean.

The clogging indicator must remain visible to the operator.

The filter must be easily accessible. Leave enough room (about 400 mm) to replace the cartridge, as shown on the drawing below :

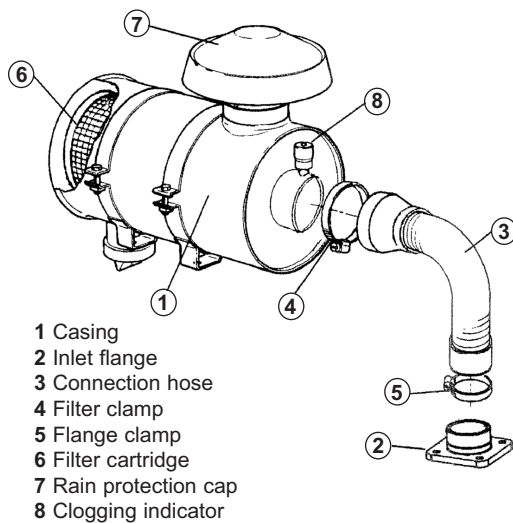
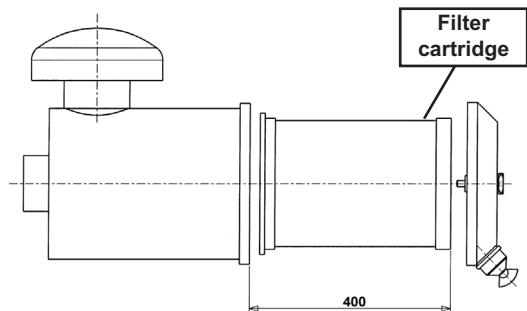

2.5 Discharge

2.5.1 Silencer

Dampens noise in pipes. It shall be positioned as close as possible to the compressor discharge.

It must be directly welded to the discharge pipe.

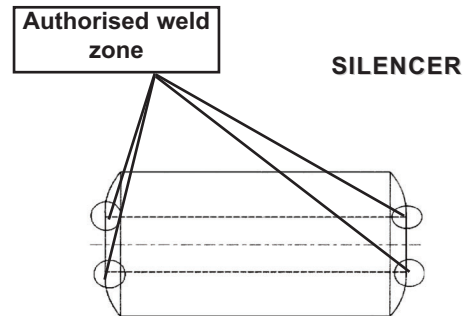

Any weld performed outside of this zone of authorized welding will seriously damage the silencer. In particular, it is not authorized to weld a fixation foot on the silencer.

2.5.2 Check valve and relief valve

The compressor must be protected by a check valve and a relief valve.

See Instructions 1401-E00 SCREW COMPRESSOR CHECK AND RELIEF VALVE.

2.6 Drive

Our screw compressors can be the object of various modes of driving, it is however necessary to take care of the adapted protection systems.

Thank you to respect the following recommendations imperatively.

Recommendations

Driving mode	Torque limiter	Specific rubber coupling (1)	Comments
PTO + Cardan	Yes	No	
Electric motor, direct	No	No	Starting up Star / Triangle
Diesel engine, direct	Yes	Yes	With or without clutch
Hydraulic motor	No	No	

(1) Type STROMAG PERIFLEX VN must be defined case by case according to the power to transmit, the speed and type of engine. This device allows to filter the vibrations of the engine which in the long term can generates the rupture of the small pinion shaft of the compressor.

2. INSTALLATION (continued)

2.6.1 Speed range

The compressor may be driven :

- Directly by a PTO shaft
- By hydraulic transmission
- By an internal combustion engine or electric motor.

Nota : Belt /pulley arrangement : **Forbidden**

The selection of the drive mode will take into account :

- The compressor mounting configuration
- The driving shaft rotation direction
- The expected power requirement for the given application
- The acceptable rpm range for the driving equipment
- The acceptable rpm range for the compressor.



The use of compressors outside of their operating speed range can lead to property damage or serious injuries. See central IOM.

The non balancing of the drive shafts can lead to mechanical ruptures that are susceptible of causing important property damage and/or serious injuries.

Not following assembly instruction can lead to mechanical ruptures that may create major property damage and/or serious injuries.

In all cases, the drive must make it possible :

- To maintain the compressor rotation speed during load variations (pressure variations).
- Not to subject the compressor to sudden or insufficient starts/stops.

2.6.2 PTO shaft drive

It is mandatory to comply with the following instructions :

- The shaft must be dynamically balanced.
- Its length and its angle must be as small as possible, see table.
- The drive shaft slides perfectly well during rotation.
- The jaws of the universal joints are parallel.
- Coupling flanges show no eccentricity nor warping of the bearing surface.
- The angle formed by the universal joint and the drive shaft must not exceed 15°.
- The compressor shaft must be parallel to that of the drive shaft.

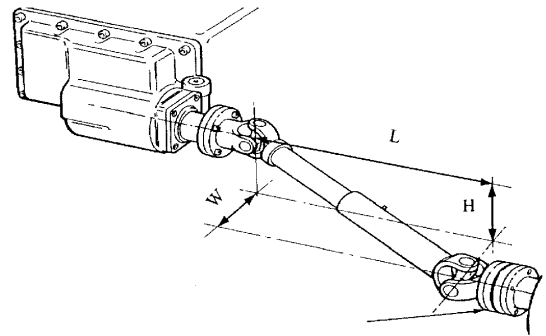

$$A = \frac{\sqrt{H^2 + W^2}}{L}$$

If H = Zero, A = W / L

If W = Zero, A = H / L

A	Universal joint angle	
0,017	1°	VERY GOOD
0,035	2°	
0,052	3°	
0,070	4°	
0,087	5°	GOOD
0,105	6°	
0,125	7°	
0,141	8°	
0,158	9°	LIMIT VALUES
0,176	10°	
0,194	11°	
0,213	12°	
0,231	13°	
0,249	14°	
0,268	15°	

To protect the P.T.O in the event of compressor stalling, **it is necessary to install a torque limiter.** The MOUVEX company shall not be held responsible for damage resulting from such stalling if this stalling is caused by wrong manipulation with the compressor or if a wrong torque limiter is installed. See Instructions 1401-B00 TORQUE LIMITER - SCREW COMPRESSORS.



If the greasing instructions for the universal joint are not respected, this can lead to ruptures of this universal joint, as well as property damage and serious injuries

2.6.3 Hydraulic drive

A hydraulic motor ISO7653 fitted with a DIN 5462 - ISO 14 shaft (same profile as the hydraulic pumps fitted on the PTOs) can be coupled to the MX12 S version 20R or MX12 N version 20L equipped with the hydraulic drive option. The hydraulic circuit must be equipped with a pressure limiter allowing tripping at a torque of 800 Nm.

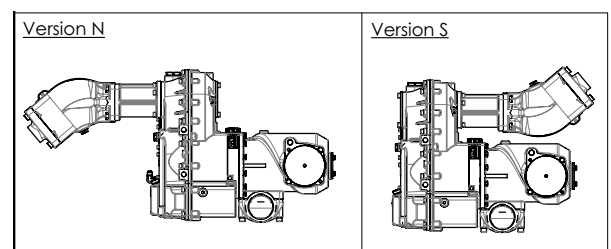

2. INSTALLATION (continued)

2.7 Oil cooler

2.7.1 Overall dimensions

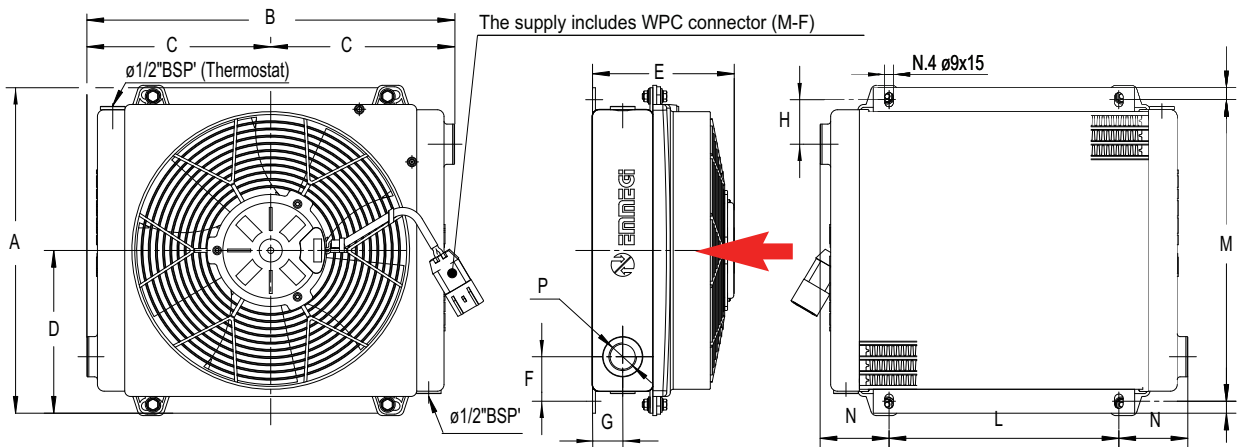

Overall dimensions and technical characteristic are not binding.

A	B	C	D	E	F	G	H	L	M	N	P
243	309	154.5	121.5	147	46	31.5	46	150	223	79.5	Ø 1" BSP

Supplied with hoses (length 2 m) and fittings.

2.7.2 Fixation

Not supplied.

Please, make sure to take care of the information given in the pictures below.

It can be also mounted horizontally, just make sure it is far enough from a wall to ensure a proper air flow.

Turn it in order to ensure the air is sucked from an external area to the truck.

The oil cooler must be also protected from impacts, vibrations and splashes.

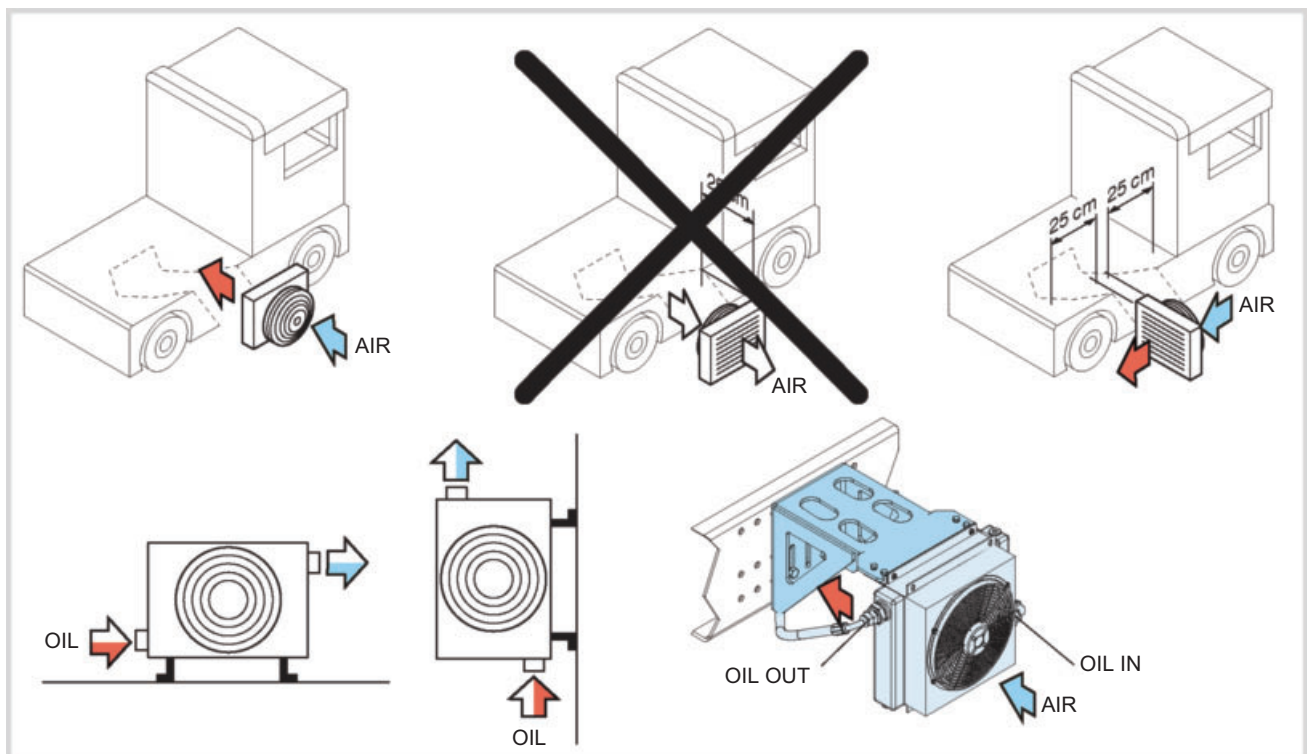

2. INSTALLATION (continued)

2.7.3 Characteristics

Tension	24 VDC
Current consumption	3,3 A
Speed	3 900 rpm
Protection standard	IP 68
Oil capacity (with hoses)	1,2 l.
Weight	5,3 kg

2.7.4 Electric connection

Electrical cabling suggested :



The current source must be cut before any intervention in the electrical circuit to prevent any damage to equipment or physical injury.

The power supply must be protected with a 6,3 A fuse (not supplied) on the power supply.

The electrical cable must be correctly supported to prevent its wear through friction, which could make the equipment live or cause unwanted microcuts.

The installer is responsible for supplying this electric line when the compressor is in use and switching it off when the compressor is not required.

To provide with power the fan use a relay able to switch 20 A. It could be controlled by a manual switch or automatic device that uses the command signal of the control drive (pneumatic or electric).

Turning off the fan while the compressor is running can cause damage to equipment or physical injury (failure of the fan or accessories on the cooled outlet ...).

Make sure of the fan direction rotation in order to take care of the air flow direction specified § FIXATION.

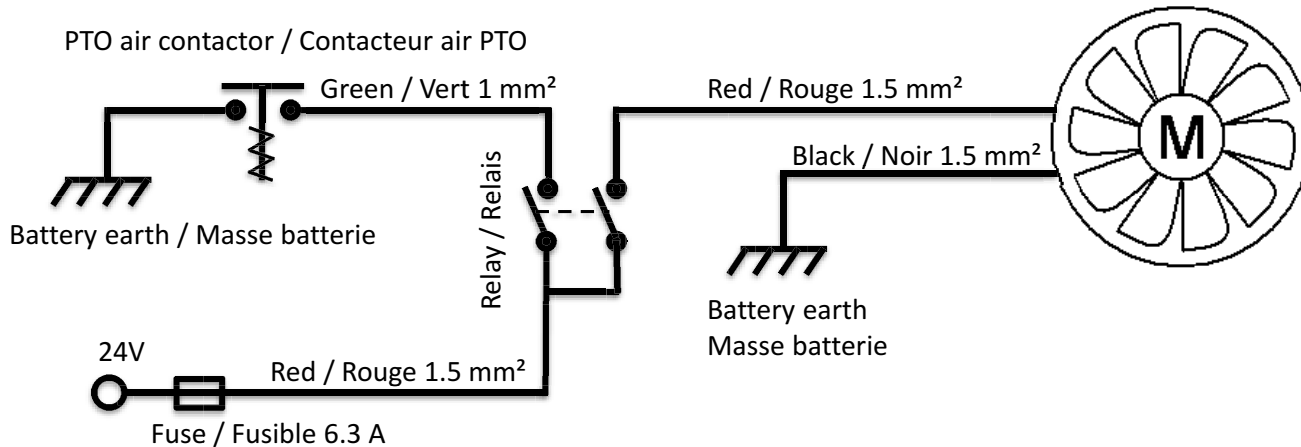

3. USE OF COMPRESSOR

The operator should remain nearby the equipment throughout the use to ensure the proper functioning of the system.

It is imperative to hold the hose in order to avoid whipping during pressurization.



3.1 Lubricant recommendations

MOUVEX BSC3 oil is recommended.

With BSC3 oil, oil change is recommended every year or 400 working hours.



In case of operations done **under minus 25°C**, BSC3 oil viscosity sharply increases and can generate starting troubles. It will be necessary, in that case, to preheat the compressor body.

It is also allowed to use oil SAE 5W40 temporarily allowing to tolerate -35°C.

That implies the following constraints :

- Oil must be replaced every 100 operating hours.
- Imperative return to the BSC3 when the temperature becomes again positive.

Oils BSC and SAE are miscible; the passage of the one with the other thus does not imply particular procedure of cleaning.

3.2 Filling of lubricant



Our compressors are delivered without oil. The use of a compressor with an incorrect oil level can lead to important property damage and serious injuries.

The quantity of oil for a MX12 compressor is approximately **4,7 l** :

- ~3,5 l inside the compressor,
- ~1,2 l inside the cooler, pipes and filter.

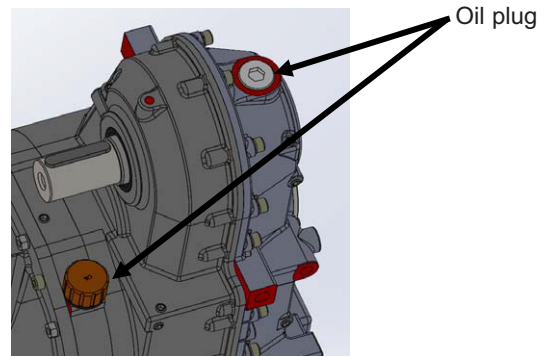

Compressor installed on the truck :

- Add around 4,5 l by the oil plug inside the compressor.
- Run the compressor for 1 min.
- Use one of the side plug in order to set up the maximum oil level. Put oil until it reach leaking level.

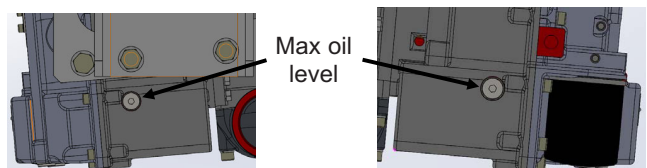

Checking the oil level can also be done via the oil dipstick located at the rear of the compressor.

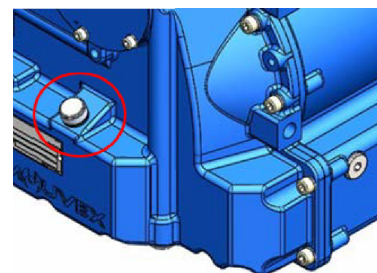

Before starting the system, fill the casing with oil until reaching the overflow level.

NB : A residual volume of 0,5 l of oil may be present inside the compressor when it leaves the factory.

After filling, the level must under no circumstances exceed the maximum oil level.

3. USE OF COMPRESSOR (continued)

3.3 Operation

- The compressor must be started with the discharge valves open.
- When it is started for the first time, check the compressor rotation direction. Also check rotation speed (refer to § TECHNICAL CHARACTERISTICS).
- The compressor shall be stopped without any counterpressure at discharge.
- At the first start, check that the combinations of rotation speed and discharge pressure of the compressors are in conformity with those indicated in § TECHNICAL CHARACTERISTICS.



Before any equipment startup, it is necessary to check the coherency between the motor rotation direction and the compressor operating direction. A startup with rotation in the wrong direction will lead to irreversible property damage on the compressors that is not covered by the guarantee.

During operation, the temperature of the surface of a compressor and nearby parts can be in the region of 200°C. The compressor and the parts located nearby are thus susceptible of provoking serious burns and property damage. Be careful to not approach elements that are sensitive to heat and affix plates informing users that the compressor is hot, to prevent any risk of burns.

3.4 Starting-up

BEFORE starting compressor, open all air valves necessary to vent the tank and compressor to atmosphere.

Verify there is no possibility of operating at pressure before compressor reaches correct speed.

Close all valves and proceed to pressurize the tank and discharge the cargo.

3.4.1 Start-up procedure for manual gear box

- Start the engine and run with standard speed.
- Depress clutch and engage the PTO.
- Release the clutch SLOWLY.
- Set engine speed to give the correct compressor speed.



3.4.2 Shutting down procedure for manual gear box

- Depress the clutch and disengage the PTO.



- Reduce engine speed to idle.



ALWAYS DISENGAGE THE DRIVE BEFORE SLOWING ENGINE DOWN.

- Release the clutch.



NOTICE :

COMPRESSOR MUST OPERATE AT FIXED SPEED WITHIN THE COMPRESSOR MODEL SPEED LIMITS. SPEED MUST REMAIN CONSTANT THROUGHOUT THE OFF LOADING OPERATION.

4. MAINTENANCE

4.1 Maintenance schedules

After every cleaning of the truck

Always run the compressor for 15 minutes to remove any water that inadvertently gets into the piping. DO NOT fog or introduce anti-corrosive liquids into the compressor to prevent corrosion : Use of liquids in the compressor will cause failure.

According to the prescriptions of § LUBRICANT RECOMMENDATIONS.

Change the compressor oil and clean the magnetic plugs.

Weekly

The compressor should be run for at least 15 minutes to prevent moisture from collecting inside. This will reduce the risk of corrosion damage to the compressor and other equipment in the piping.

Clean the compressor outer surfaces. Inspect DAILY if operating in dirty or severe environment. Check the condition of the inlet filter hose for splits and tears. Replace or repair as necessary.

Inspect compressor, system piping and components. Clean or repair as necessary.

Monthly

Check oil level, add the necessary volume if necessary.

Check for cleanliness the breather, clean with an air blower if necessary.

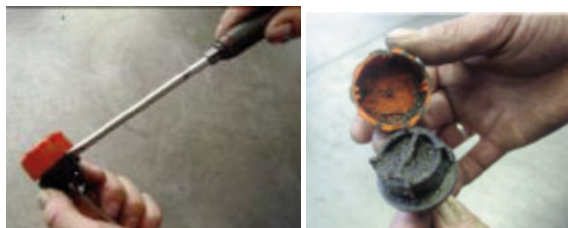

 CAUTION	<p>THE BLOWING OF OIL GAUGE CAN CAUSE PERSONNAL INJURY OR PROPERTY DAMMAGE. IT IS MANDATORY TO CARRY APPROPRIATE PROTECTIONS (GLOVES, GLASSES...) TO AVOID RISKS OF PERSONNAL INJURY.</p>
---	---



4.2 Compressor oil change procedure

Oil gauge : See § LUBRICANT RECOMMENDATIONS.

Replace the oil filter at each oil change.

4.3 Air filter replacement procedure

Check weekly the clogging indicator. When it turns red, replace the filter cartridge.

Before installing a new cartridge, clean the internal part of the filter housing with a clean damp cloth.



The presence of foreign bodies in the compressor inlet channel is susceptible of leading to serious property damage or serious injuries.

4.4 Drive train inspection

4.4.1 PTO Drive

Check monthly that there is no clearance in the jaws and PTO cross pieces by turning the universal joint manually in one direction then in the other direction. Lubricate the universal seal as per manufacturer' s recommendations.

4.5 Check valve and relief valve inspection

See Instructions 1401-E00 SCREW COMPRESSOR CHECK AND RELIEF VALVE.

5. TROUBLESHOOTING

CAUTION :
OBSERVE ALL SAFETY WARNINGS CONTAINED IN THIS MANUAL.

Problem	Possible origin	Possible solution
1. Pressure issue	Too much pressure drop.	To check pipes diameter.
	Relief valve damaged.	To check the opening point.
	No return valve damaged.	To check the proper operating of the No return valve.
2. Flow rate issue	Wrong Compressor speed.	To adjust the speed by taking care of the range allowed.
	Relief valve damaged.	To check the opening point.
3. Abnormal high temperature	Air filter clogged.	To clean the cartridge or to replace it.
	Air pressure too much high.	To see problems 1. / 2.
	Outside temperature too much high.	To respect the maximum external temperature allowed.
	Lack of oil.	To check the oil level.
	Compressor speed too much low.	To adjust the speed by taking care of the range allowed.
	The oil cooler fan does not turn.	Check the fuse and the fan motor.
4. Inlet pressure drop > 75 mbar (clogging indicator red)	Air filter clogged.	To clean the cartridge or to replace it.
	Air inlet hose folded.	To check the air inlet hose.
5. Compressor doesn't operate	Torque limiter damaged.	To replace the torque limiter.
	Transmission damaged.	To consult your Service point.
6. Torque limiter damaged	Screw Compressor damaged.	To consult your Service point.
	Wrong motor / transmission management.	To consult your Truck dealer.
	Oil too much viscous.	To be in compliance with the MOUVEX Instructions.
7. Oil leak	Too much oil.	To check the oil level.
	Oil breather clogged.	To clean the oil breather.
8. Vibrations	Wrong motor speed.	To increase the speed by taking care of the range allowed.
	Transmission damaged.	To check the driving shaft.
	Lack of rigidity of the chassis.	To be in compliance with the Truck Manufacturer Instructions.

6. WARRANTY

6.1 Warranty claims

The following parts are considered as wear parts :

- Inlet filter cartridge
- Compressor oil

No failure connected with wear part damage will be accepted under warranty conditions.

The following situations will void warranty for all components :

- Tampering with the setting of the relief valve.
- Presence of foreign body inside the compressor body.
- Traces of damage representative of abnormal use of the compressor.
- Use of non genuine parts.
- If the compressor is repaired by a repairer who is not a MOUVEX-approved repairer.
- Construction of the package not validated by our Design Office.
- Use of an oil other than BSC3 (provide invoices).
- No oil cooler.
- No heat shrinkable sleeves and collars in place on inlet hose.

Before returning your equipment to the factory, you must first obtain an Equipment return approval (RMA) from our After Sales Department.

A Compressors form information shall be filled by the installer or distributor and sent to MOUVEX in order to claim for a warranty.

6.2 24-months warranty extension with BSC3 oil

The 24-months warranty extension with BSC3 oil option increases the warranty for the screw compressor to 60 months :

- Europe zone only,
- Only concerns the bare shaft compressor with or without multiplier, excluding packages and accessories (air filter, torque limiter, check relief valve...),
- Use of BSC3 oil (provide invoices),
- Conditions identical to the current standard warranty.

7. STORAGE CONDITIONS

7.1 Compressor

The equipment must be systematically stored in an area sheltered from bad weather.

The equipment must bear its original protective components until it is installed in its final application.

If installation is interrupted, put back in place the original protective components or equivalent components.

7.2 BSC oil

In its unopened original container in a dry, frost-free and light-free place.

The maximum shelf life is approx. 60 months.

8. SCRAPPING

The compressor must be scrapped in compliance with the regulations in force.

During this operation, particular care must be paid to the drainage stages of the compressor.

9. OVERALL DIMENSIONS (continued)

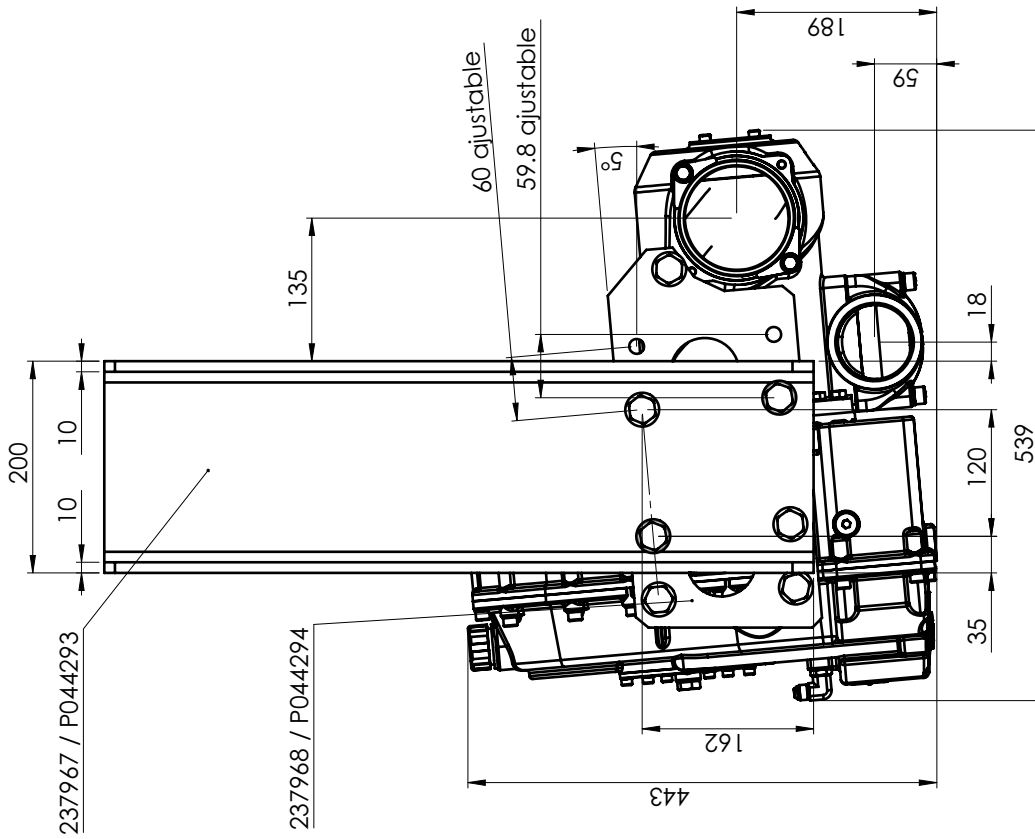

NOTES:

1. 3 positions possibles (Position 2 représentée/represented)

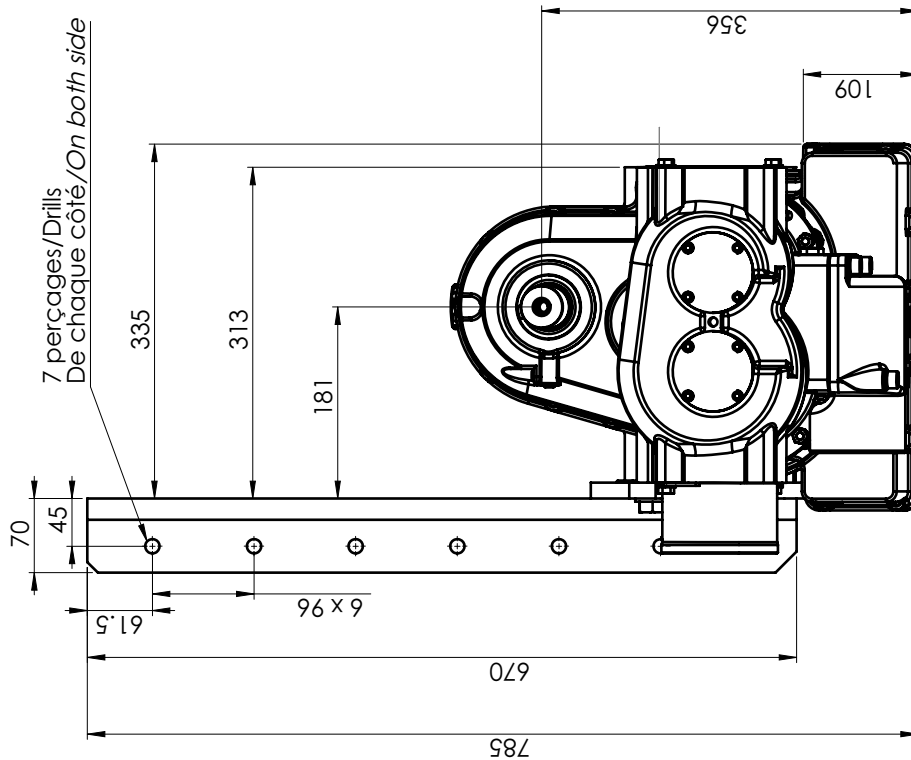

UNLESS OTHERWISE SPECIFIED, ALL DIMENSIONS ARE IN MM

Poids compresseur nu /
Bare compressor weight :
104 kg