



Instructions 1013-D00 (En)

Section	1013
Effective	December 2025
Replaces	June 2025

Original instructions

PUMPS

G-FLO 6 - G-FLO 8 - G-FLO 11 - G-FLO 15
G-FLO 25 - G-FLO 40 - G-FLO 50 - G-FLO 65
Constructions S - HP - HT

G-FLO 6/8

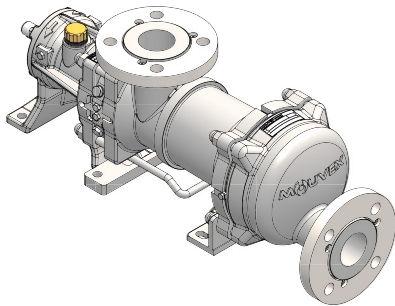

G-FLO 11/15/25/40/50/65

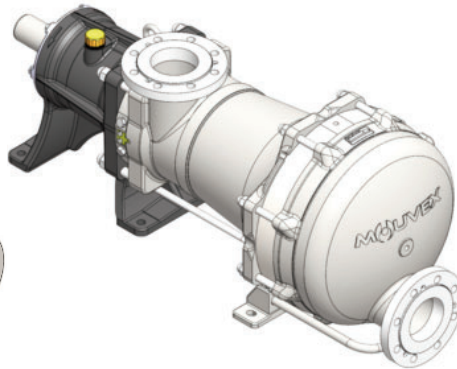

INSTALLATION

OPERATION

MAINTENANCE

EC CERTIFICATE OF CONFORMITY :

The EC Certificate of Conformity (paper version) is systematically attached to the equipment when shipped.

WARRANTY :

G-FLO Series pumps are covered 24 months by warranty within the limits mentioned in our General Sales Conditions. In case of a use other than that mentioned in the Instructions manual, and without preliminary agreement of MOUVEX, warranty will be canceled.

PATENTS :

For relevant patents on this product refer to : www.psgdover.com/patents



Z.I. La Plaine des Isles - F 89000 AUXERRE - FRANCE
Tel. : +33 (0)3 86 49 86 30
contact.mouvex@psgdover.com - www.mouvex.com

Your distributor :

ECCENTRIC PISTON PUMP

MOUVEX PRINCIPLE

SAFETY INSTRUCTIONS, STORAGE, INSTALLATION AND MAINTENANCE

6 - 8 - 11 - 15 - 25 - 40 - 50 - 65 MODELS

Definition of safety symbols



This is a SAFETY ALERT SYMBOL.

When you see this symbol on the product, or in the manual, look for one of the following signal words and be alert to the potential for personal injury, death or major property damage.



Warns of hazards that WILL cause serious personal injury, death or major property damage.



Warns of hazards that CAN cause serious personal injury, death or major property damage.



Warns of hazards that CAN cause personal injury or property damage.

NOTICE

Indicates special instructions which are very important and must be followed.

TABLE OF CONTENTS

Page

1. INSTALLATION	.4
1.1 Installation design	.4
1.2 Orientation of the pump ports	.5
1.3 Direction of rotation	.5
1.4 Protection of the pump installation	.6
1.5 Hoisting devices	.7
1.6 Unit Assembly	.7
2. UTILISATION	.10
2.1 Noise level	.10
2.2 Commissioning	.10
2.3 Dry running	.10
2.4 Pump stop	.10
2.5 Scrapping	.10
3. CLEAN IN PLACE (CIP) & STERILISATION IN PLACE (SIP)	.11
3.1 General	.11
3.2 CIP circuit recommended	.11
3.3 Pumps arranged in series	.11
3.4 Pumps arranged in parallel	.12
3.5 Successive cycles	.13
3.6 Sterilisation In Place (SIP)	.13
4. MAINTENANCE	.13
4.1 Tightened torques (N.m)	.13
5. OPENING OF THE PUMP	.14
5.1 Assembly / dismantling FLO 6 - FLO 8	.15
5.2 Assembly / dismantling FLO 11 to FLO 65	.16
5.3 Checking of cylinder and piston	.17
5.4 Checking cylinder / piston set in case of disassembly	.18
6. ASSEMBLY OF CYLINDER/PISTON	.19
6.1 FLO 6 - FLO 8	.19
6.2 FLO 11 to FLO 65	.20
7. CHANGING THE LIP SEAL	.21
8. CHANGING THE ORIENTATION OF THE PORTS	.22
8.1 Discharge port	.22
8.2 Suction port	.22
8.3 Flanges dismantling	.23
8.4 Flanges reassembly	.23
9. DRAINING OF BEARING	.24
10. STORAGE	.25
10.1 Short duration (\leq 1 month)	.25
10.2 Long duration ($>$ 1 month)	.25
10.3 Restarting	.25
11. TROUBLESHOOTING	.26

TECHNICAL CHARACTERISTICS

TECHNICAL CHARACTERISTICS

- Maximum pump speed (rpm) :

FLO 6 FLO 8	FLO 11 FLO 15	FLO 25	FLO 40	FLO 50	FLO 65
1000	600	525	460	400	350

- Running temperatures :

- ambient-15°C → + 50°C
- continuous pumped product :
 - standard version-15°C → +100°C
 - version HT (Haute Température).....-15°C → +160°C
- washing / rinsing / sterilisation product..... 0°C → +121°C
- heating fluid (jacket)-15°C → +180°C

- Maximum suction pressure :

- In normal use, the suction pressure must be higher than the required NPSH and **less than 2 barg** (29 psig)
- During **CIP/SIP** of the pump, the suction pressure must not exceed **3 barg** (43,5 psig) or **6 barg** (87 psig) if pump with ECS.
- Pump **stopped**, the pressure must not exceed **6 barg** (87 psig).

- Acceptable maximal differential pressure* :

- FLO 6/11/15/25/40/50 S10 bar (145 psi)
- FLO 8/65 S 7 bar (101 psi)
- FLO 65 HP10 bar (145 psi)

- Maximum pressure jacket ...5 barg (72,50 psig)

- Cylinder capacity (liters) :

FLO 6	FLO 8	FLO 11	FLO 15	FLO 25	FLO 40	FLO 50	FLO 65 S	FLO 65 HP
0,111	0,148	0,340	0,463	0,882	1,646	2,315	3,378	2,601

* When the pump works with an inlet gauge pressure less than zero, the maximum outlet pressure will be calculated as if the inlet pressure is equal to zero.

USED PRESSURE UNITS

Unit without suffix :

Differential pressure, for example, pressure difference between equipment suction and discharge.

Unit with suffix "a" :

Absolute pressure.

Unit with suffix "q" :

Gauge pressure, given regarding to atmospheric pressure (~101325 Pa, taken at 1 bar / 14,5 psi in this IOM).

Example :

$P_{suc} = -0,2 \text{ barg} = 0,8 \text{ bara}$

$P_{dis} = 8,8 \text{ barg} = 9,8 \text{ bara}$

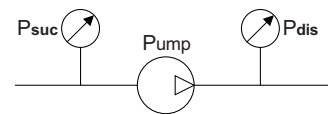

$\Delta P = P_{dis} - P_{suc} = 9 \text{ bar}$



Maximum drive torque (N.m)

Version	Maximum torque at	FLO 6	FLO 8	FLO 11	FLO 15	FLO 25	FLO 40	FLO 50	FLO 65
Standard	100°C	28,00	28,00	103,00	103,00	171,00	313,00	446,00	603,00
	110°C	28,00	28,00	103,00	103,00	171,00	313,00	446,00	-
HT	120°C	26,32	26,32	96,82	96,82	160,74	294,22	419,24	
	130°C	24,64	24,64	90,64	90,64	150,48	275,44	392,48	
	140°C	22,96	22,96	84,46	84,46	140,22	256,66	365,72	
	150°C	21,28	21,28	78,28	78,28	129,96	237,88	338,96	
	160°C	19,60	19,60	72,10	72,10	119,70	219,10	312,20	

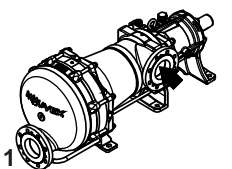
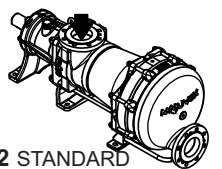
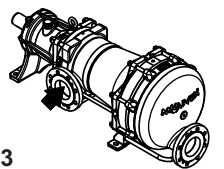
1. INSTALLATION

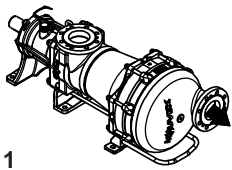
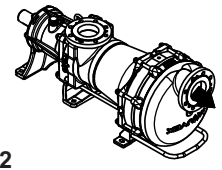
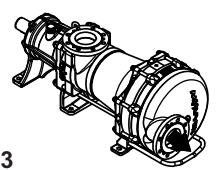
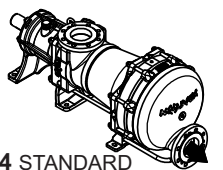
	POSSIBLE POSITIONS			
SUCTION	 1	 2 STANDARD	 3	 4
DISCHARGE	 1	 2	 3	 4 STANDARD

For a pump with suction lift (liquid level below pump level), rather use suction port position 3 to limit possible air pockets.

To avoid any product retention inside the pump, put discharge port in position 4.



1.1 Installation design

1.1.1 Pump

To obtain the service expected from a MOUVEX pump, regarding both performance and longevity, it is vital that the type of pump, its speed and the materials used for its construction are determined as a function of the pump output, its installation and operating conditions.

You can contact our Technical Services at any time to ask for the information you require.

1.1.2 Pipe

- Not recommended 
- To be avoided if possible 
- Recommended 

Suction pipe length

Length should be as short as possible.

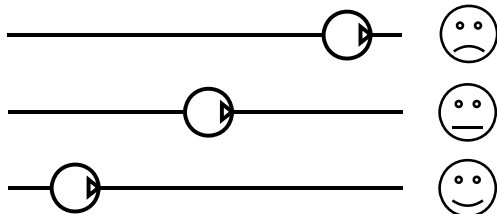

Suction pipe diameter

Diameter must be at least equal to pump port diameter and even more if required by pumping conditions.

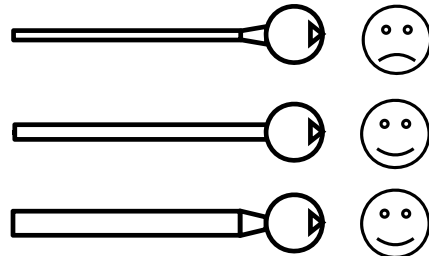

Suction pipe configuration

Check tightness to avoid accidental air intake.

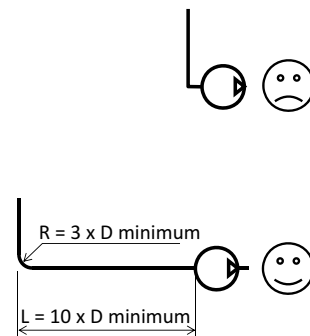
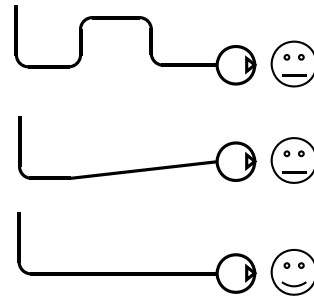

1. INSTALLATION (continued)

Pipe alignment and supporting

Pump must not support piping nor endure stress resulting from piping weight or dilatation effects. For latters, expansion loops should be included.

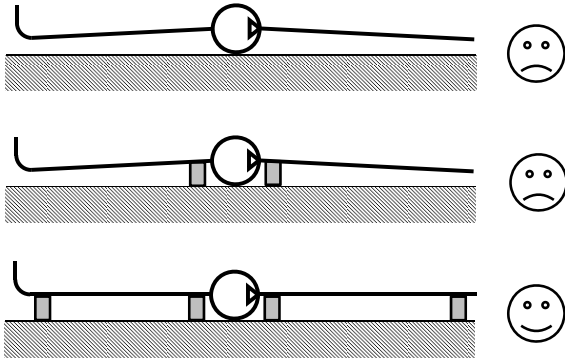

Pipe equipment

- Place valves close to the pump to avoid draining pipe during maintenance operations. Preferably select full bore ball or butterfly valves.

Pressure connections on pump suction and discharge are recommended for settings and controls.

Make sure piping, vessels valves and other installation devices are carefully cleaned before mounting.

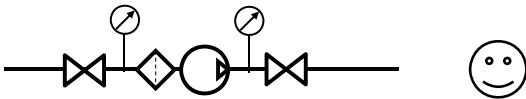

- MOUVEX pumps are self priming. However, if line emptying should be avoided and/or if suction lift is high, a foot valve can be added.

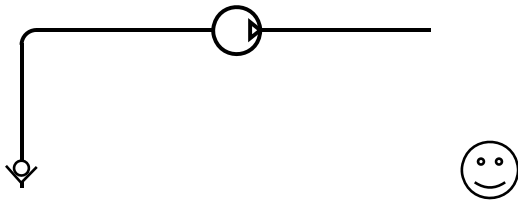

- If pumped liquid presents a risk of in pipe solidification and potential dilatation, low points on the pipe should be avoided or equipped with drain valve.

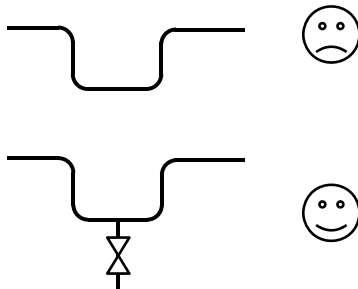

- If installation is heated, it must be designed so that fluid dilatation can evacuate through piping. Therefore fluid contained in piping must be heated before fluid contained in the pump. Also check that a heated pump is not isolated by closed valves.

The G-FLO Series pump is a selfpriming volumetric PD pump. Therefore, the pump must not run on a circuit with a closed valve. This is valid both for the suction circuit and for the discharge circuit.

For hoses fitting on pump suction or discharge, a hose whip restrain device must be installed to limit the whip or travel of the pressurized hose at start up, or in case the hose breaks free.



WARNING: SEVERE PERSONAL INJURY OR PROPERTY DAMAGE CAN CAUSE FROM WHIPPING HOSES.

1.2 Orientation of the pump ports

The suction and discharge ports may be oriented in various positions.

If the ports positions needs to be changed at any time, see the corresponding paragraph.

NOTICE

G-FLO-Series pumps remains drainable whatever position is chosen for the inlet port, but the outlet port must be at the bottom (position 4) to keep the self-draining capability.

1.3 Direction of rotation

An arrow situated on the bearing housing indicates the correct direction of rotation.

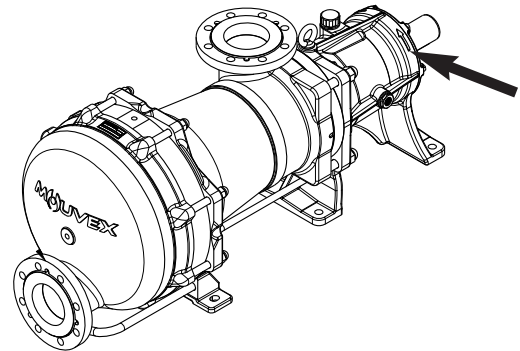



When looking at the shaft, the rotation will be clockwise. When looking at the front cover, the direction of rotation will be anti-clockwise.



Verification of the correct rotation direction : Turn the pump the wrong way is not dangerous for the pump.



1. INSTALLATION (continued)

1.4 Protection of the pump installation

- Before any start-up, during operation or complete stopping of the pump, make sure the valves are open.
- During stop periods, with the pump full of product, either the suction or discharge circuit must be left open to enable expansion or contraction of the pumped product through reheating or cooling. If this instruction is not complied with, The bellows may be damaged and lead to pre-mate failure.
- The bearing must be ventilate at all times, therefore the breather mounted on the bearing must be re-used. Never put the plug on.
- The stop time may lead to cooling of the product in the pump and therefore to an increase in viscosity. If this is the case, we recommend re-starting the pump at a speed adapted to this new viscosity (starting pump). Once the product arrives in the pump at the installation definition temperature, the pump may run at the speed specified for this application.
- Protection against excess pressure :
The pump must be protected against excess pressure. It can be delivered with a pressure switch to carry out this function. If protection is provided by a control valve, check that the system does not generate excess pressure at the bellows (particularly if there are water hammers). Operating in this way will damage the bellows and shorten their lifetime.

 <p>WARNING</p>	<p>INCORRECT SETTINGS OF THE PRESSURE RELIEF VALVE CAN CAUSE PUMP COMPONENT FAILURE, PERSONAL INJURY, AND PROPERTY DAMAGE.</p>
	
<p>Hazardous pressure can cause personal injury or property damage.</p>	

 <p>WARNING</p>	<p>FAILURE TO INSTALL ADEQUATELY SIZED PRESSURE RELIEF VALVE(S) CAN CAUSE PROPERTY DAMAGE, PERSONAL INJURY OR DEATH.</p>
	
<p>Hazardous pressure can cause personal injury or property damage.</p>	

 <p>WARNING</p>	<p>PUMPS OPERATING AGAINST A CLOSED VALVE CAN CAUSE SYSTEM FAILURE, PERSONAL INJURY AND PROPERTY DAMAGE.</p>
	
<p>Hazardous pressure can cause personal injury or property damage.</p>	

- Protection against foreign bodies :

The pump and the installation must also be protected against any risk of damage through the passage of foreign bodies by mounting a prefilter at the pump suction.

In the case of foreseeable clogging of the pre-filter, we recommend using a vacuum switch to inform the user of pre-filter clogging. Prolonged running under cavitation may damage the pump.

The largest dimensions [mm (in)] of the allowable particles in the pump are :

	FLO 6 FLO 8	FLO 11 FLO 15	FLO 25	FLO 40	FLO 50	FLO 65
Soft particles	8 (0,315)	12 (0,472)	14 (0,551)	17 (0,670)	20 (0,788)	20 (0,788)
Hard particles	0,89 (0,035)	0,76 (0,03)	0,97 (0,038)	1,4 (0,055)	1,39 (0,055)	3,4 (0,134)

- Bellows monitoring :

Pump with BMS (Bellows Monitoring System) : see Instructions NT 1011-S00 BELLOWS MONITORING SYSTEM C SL FLO.

For these designs it is imperative to take the following precautions :

- insulate the inlet manifold and the front cover when difference between ambient and pumped product temperatures is greater than 120°C.
- ensure that the thermal insulation limits the temperature difference between the tierods and the pumped product to 120°C.
- Do not insulate or cover the bearing case not to impact the bearings life span.
- If the pump is equipped with one, do not insulate the BMS (bellows control device) or the ECS (pump opening device by compressed air).

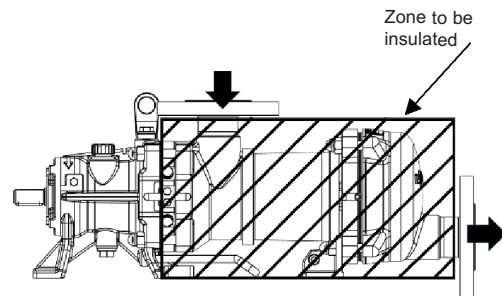

1. INSTALLATION (continued)

1.5 Hoisting devices

Put a sling in the lifting ring of the transmission and another under the pump cylinder.

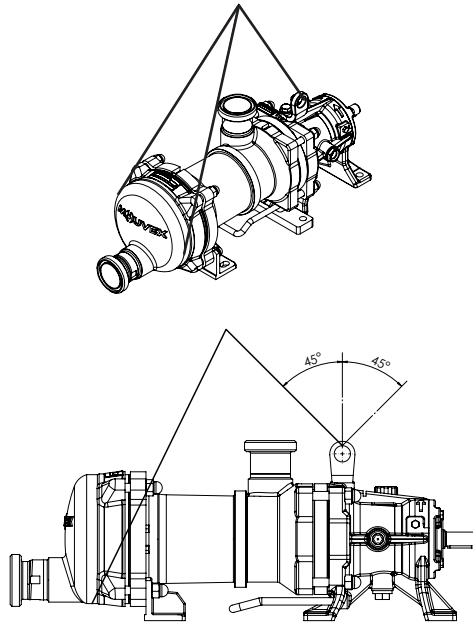

1.6 Unit Assembly

The following instructions apply to pumps delivered with a bare shaft or for MOUVEX motor-driven pump units (if the latter have no specific instruction notice).

1.6.1 INSTALLATION OF UNITS

	WARNING
	<p>BE CAREFUL WITH THE WEIGHT OF THE PARTS WHEN THEY ARE BEING REMOVED.</p>
<p>The weight of the parts can be dangerous and may provoke bodily injuries or material damages.</p>	

	WARNING
	<p>DISCONNECT THE ELECTRICITY SUPPLY BEFORE ANY MAINTENANCE OPERATION.</p>
<p>Dangerous voltage. Can cause injury and death.</p>	

FLO 25 - 40 - 50 - 65 :

The base below the unit is fundamental to ensuring correct operation and long service life. The unit's base must be flat, level and sufficiently resistant to absorb the stresses caused by the motor-driven pump unit without deformation (if it is made of concrete, it must comply with the BAEL 91 standard). The unit must be fastened in 6 points using securing lugs or bolts, it must be carefully wedged to avoid deforming the frame while the bolts are tightened. A deformed frame would apply damaging stresses on the pump and the drive mechanism and misalign the coupling, causing vibrations, noise and premature wear. Ensure that the frame is well above the floor, except from the support plates.

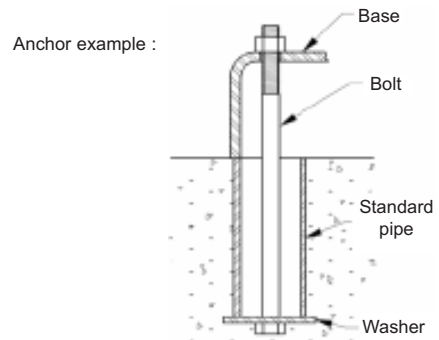



FLO 6 - 8 - 11 - 15 - 25 - 40 - 50 - 65 :



If the unit is to be used in a food environment, support plates that allow the unit to be lifted for easier cleaning are recommended. Allow, if possible, a clear space of approximately 50 cm on each side of the motor-driven pump unit (overall dimensions) to facilitate cleaning and give access if necessary to the pump, reduction gear and motor fastening nuts. In all cases, the dimensions around the motor-driven pump unit must be designed to give the space required for dismantling the pump (if the need arises, use the values given on the overall dimension drawing).

For staff and equipment protection, the frame includes a ground connection point that should be used.

1. INSTALLATION (continued)

1.6.2 ALIGNMENT OF THE MOTOR/PUMP OR REDUCTION GEAR/PUMP SHAFTS

 WARNING	<p>IF OPERATED WITHOUT THE SHAFT GUARD, THERE IS CONSIDERABLE RISK OF SEVERE PERSONAL INJURY, SIGNIFICANT PROPERTY DAMAGE OR EVEN DEATH.</p>
	
<p>Do not operate without guard in place.</p>	

 WARNING	<p>DISCONNECT THE ELECTRICITY SUPPLY BEFORE ANY MAINTENANCE OPERATION.</p>
	
<p>Dangerous voltage. Can cause injury and death.</p>	

NEVER START A UNIT IF THE COUPLING ALIGNMENT IS INCORRECT. THIS IS A CONDITION OF OUR GUARANTEE.

REMINDER :

Coupling must never be used to compensate for a misalignment.

To control the alignment between the coupling and the shaft, use a straight-edge for concentricity and thickness gauges for angular misalignment (see instructions of the coupling for authorised values).

The 3 figures below show in detail the operation and the possible defects :

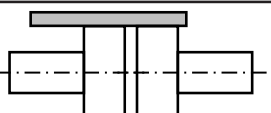
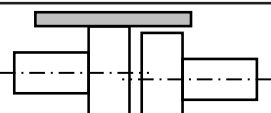
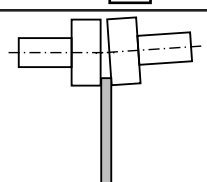
<p><i>Carry out the control at four points : at the top - at the bottom - left - right</i></p>	
	<p><i>Correct</i></p>
	<p><i>Bad alignment</i></p>
	<p><i>Angular fault</i></p>



Controlling the alignment at each stage of the installation is important to be sure that none of these stages have generated stresses on the unit or the pump :

- after fastening on the foundations.
- after fastening the pipes.
- after the pump has been operated at the normal operating temperature.

Where the pumps are supplied assembled as a unit, the motor and pump shafts have been perfectly aligned in the factory before delivery, but they must be systematically controlled on acceptance at the site and realigned if necessary.

To do this, do not modify the wedging of the various parts, but check the flatness of the support surface and use the adjustable foot to clear the frame of stresses that could affect it.

1.6.3 ELECTIC MOTORS



 WARNING	<p>DISCONNECT THE ELECTRICITY SUPPLY BEFORE ANY MAINTENANCE OPERATION.</p>
	
<p>Dangerous voltage. Can cause injury and death.</p>	

Check the compatibility of the instructions on the motor with the supply voltage.

Follow the wiring diagram, use wiring that is appropriate for the power and be particularly careful about the contacts which must be well tightened.

The motors should be protected with circuit breakers and suitable fuses. Connect the regulatory electrical grounding.

1.6.4 THERMIC MOTORS



 CAUTION	<p>THE SURFACES CAN BE AT A TEMPERATURE LIABLE TO CAUSE INJURY OR SEVERE DAMAGE.</p>
	
<p>Excessive temperature can cause injury or severe damage.</p>	

Do not forget that these motors are not reversible. It is absolutely necessary to carefully control the suction and discharge sides of the pump before connecting the group to the piping.

Using electric motors is very common now; however, we strongly advise careful reading of the accompanying instruction manual.

1. INSTALLATION (continued)

1.6.5 CONTROL OF THE SENSE OF ROTATION

	WARNING
	<p>TAKE ALL NECESSARY MEASURES TO RENDER ANY START-UP, EVEN ACCIDENTAL, OF THE PUMP DURING THE WORK IMPOSSIBLE.</p>
<p>Any unforeseen start-up can cause serious injuries or important material damages.</p>	



This control needs to be done with no liquid pumped through the pump, and both the suction and discharge circuits venting to avoid generating unexpected pressure (at the suction side, for example). This will ensure that the control will not damage either the pump or the installation.



Start the pump empty to check that the connections are good and that the direction of rotation corresponds to the suction and discharge direction on the installation. If it is necessary to reverse the direction of rotation, follow the instructions below :

Three-phase motor : switch any 2 current input wires.

Bi-phase motor : switch two same phase wires.

Single-phase motor : follow the instructions on the notice supplied with the motor.

	WARNING
	<p>IT IS IMPERATIVE THAT THE HYDRAULIC PRESSURE IS RELEASED BEFORE EACH MAINTENANCE OPERATION TO AVOID PERSONAL INJURY OR MATERIAL DAMAGE</p>
<p>Hazardous pressure can cause personal injury or property damage.</p>	

	WARNING
	<p>IF OPERATED WITHOUT THE SHAFT GUARD, THERE IS CONSIDERABLE RISK OF SEVERE PERSONAL INJURY, SIGNIFICANT PROPERTY DAMAGE OR EVEN DEATH.</p>
<p>Do not operate without guard in place.</p>	

2. UTILISATION

2.1 Noise level

The sound level of a pump is greatly influenced by its conditions of use. Cavitation and pumping products with high gas contents generally increases the sound level.

Under the following pumping conditions :

- excluding cavitation
- discharge pressure :
 - FLO 6/11/15/25/40/50 S . . . 6 bar (87 psi)
 - FLO 8/65 S 7 bar (101 psi)
 - FLO 65 HP 10 bar (145 psi)
- speed of rotation :
 - FLO 6/8 S1000 rpm
 - FLO 11/15 S600 rpm
 - FLO 25 S525 rpm
 - FLO 40 S460 rpm
 - FLO 50 S400 rpm
 - FLO 65 S350 rpm
 - FLO 65 HP350 rpm
- product viscosity of 10 cSt



The sound level reached for the G-FLO pump in good conditions without the drive is less than 85 dB(A) at 1 m from the surface of the machinery and at a height of 1,6 m from the floor.

2.2 Commissioning

Make sure that the circuit valves are open before starting the pump.

To avoid any risk of polluting the product to be pumped, rinse the whole installation before starting-up so as to eliminate any contaminants that may remain in the piping, tanks etc. at the time of installation.

For any pure water pumping during process or cleaning operations, consult Mouvex imperatively.

 <p>CAUTION</p>	
	<p>THE SURFACES CAN BE AT A TEMPERATURE LIABLE TO CAUSE INJURY OR SEVERE DAMAGE.</p>
<p>Excessive temperature can cause injury or severe damage.</p>	

2.3 Dry running

The G-FLO series pump is self priming and is capable of emptying the pipes. To do this, it can run dry for a maximum duration of :

- FLO 6/8 S4 minutes
- FLO 11/15/25/40/50/65 S/HP6 minutes

2.4 Pump stop

So as not to damage the pump, make sure that the pump is completely stopped before closing the valves.

2.5 Scrapping

The pump must be scrapped in compliance with the regulations in force.

During this operation, particular care must be paid to the drainage stages of the pump (pumped product) and of its transmission (lubricant).

3. CLEAN IN PLACE (CIP) & STERILISATION IN PLACE (SIP)

3.1 General

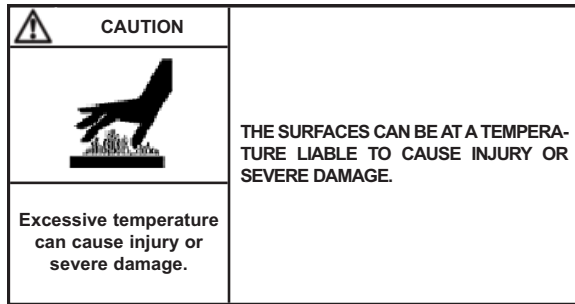

On-site cleaning (CIP) of an installation is undertaken by circulating various cleaning solutions through the equipment parts.

An automated CIP system enables :

- Preparation of the appropriate concentrations for the different cleaning solutions.
- Re-heating of certain cleaning solutions at the optimum temperature.
- Circulation of the different solutions through the equipment parts to be cleaned.
- Rinsing and drying of the equipment parts.

For the most part, automated CIP systems are an integral part of process equipments.

Before starting CIP and if the process has not been followed by a water flush, care must be taken that a minimum of residual products remains in the piping and in the pump. The G-FLO pumps, thanks to their excellent suction and compression capabilities, enable reducing the quantities of residual products. This minimises loss of products, eases cleaning and reduces cycle times.

The start of CIP must immediately follow the end of the process to avoid any clogging or untimely drying.



Non-compliance with this instruction may lead to rapid wear of cylinder and piston.

3.2 CIP circuit recommended

In all cases, the pressure at the pump inlet during cleaning **must not exceed 3 barg (43,5 psig) or 6 barg (87 psig) if pump with ECS**. See Instructions NT 1011-W00 ECS SYSTEM SERIE G_H FLO.

The flow through the pump required for optimal cleaning is :

- FLO 6/8 **10 - 21 m³/h**
- FLO 11/15 **17 - 34 m³/h**
- FLO 25/40 **27 - 54 m³/h**
- FLO 50/65 **42 - 85 m³/h**

This flow corresponds to difficult cleaning (sticky and viscous products). It can be reduced for easier types of cleaning.

3.3 Pumps arranged in series

This type of assembly is preferred in all cases. It ensures optimal cleaning for the pump and makes use of the special design of the G-FLO, i.e. the possibility of lifting the piston with the cleaning product.

As the pressure at the pump inlet is higher than that at its outlet, the piston lifts from the cylinder and permits the passage of all the cleaning liquid through the G-FLO pump.

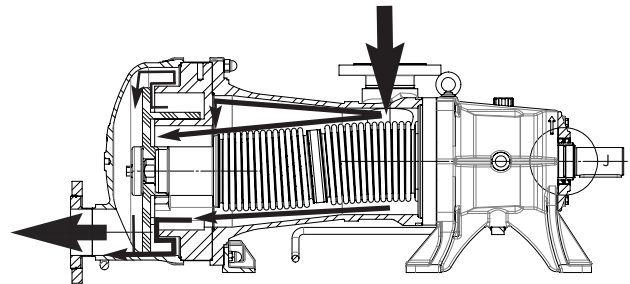

- A centrifuge pump is used for CIP cycles. This pump is placed upstream of the G-FLO pump.

The centrifuge pump must be installed in series with the G-FLO pump.

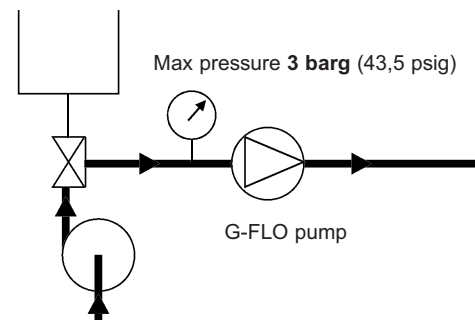

It is preferable not to run the G-FLO pump during CIP although low speed (< 100 rpm) is acceptable by alternating start/stop operation.

- In certain cases, the flow of the cleaning liquid required for the installation is higher than that recommended for cleaning the pump. In this case, a bypass must be used.

The bypass valve is adjusted to divide the flow between the circuit flowing through the G-FLO pump and the bypass circuit.

3. CLEAN IN PLACE (CIP) & STERILISATION IN PLACE (SIP) (continued)

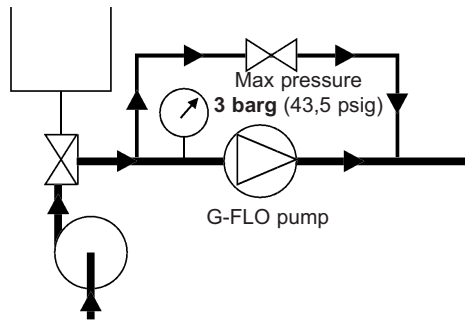

It is preferable not to run the G-FLO pump during CIP, although low speed (< 100 rpm) is acceptable by alternating start/stop operation.

- In certain cases, the cleaning pressure required for the installation is higher than 3 barg (43,5 psig). In this case, the use of a bypass is required and cleaning is done in 2 steps.

Cleaning the pump :

The cleaning flow should be limited during the cleaning of the G-FLO pump to ensure a maximum pressure of 3 barg (43,5 psig) at the G-FLO pump inlet.

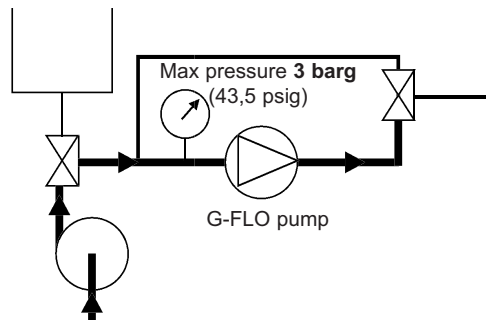

It is preferable not to run the G-FLO pump during CIP although low speed (< 100 rpm) is acceptable by alternating start/stop operation.

Cleaning the installation :

During this operation, the valve system used must ensure that no flow can pass through the pump so that the G-FLO pump does not rotate. Under these conditions, with the pump completely stopped, the pressure of the washing circuit can rise up to 6 barg (87 psig).

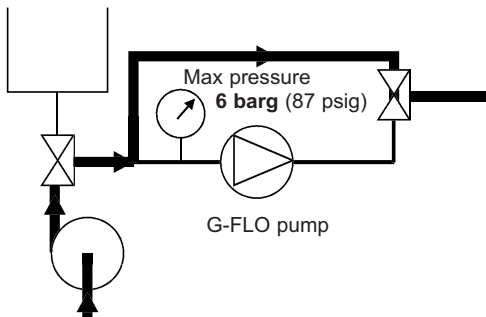

The pump must not run during this operation.

3.4 Pumps arranged in parallel

For applications where cleaning is easy and the differential pressure of, the G-FLO pump is lower than 2 bar (29 psi) during this operation, assembly in parallel is authorised. It should be noted that during cleaning, the G-FLO pump will be acting on a product with generally few lubricating properties. This will contribute towards wear of the pump.

The CIP centrifuge pump must never be installed in parallel with a G-FLO pump without taking special precautions.

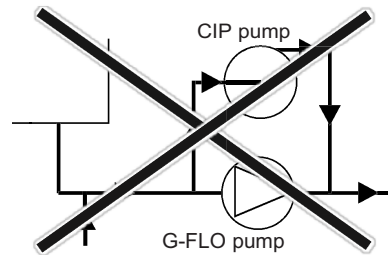

Indeed, in this case, the pressure at the inlet of the G-FLO pump is lower than the pressure at the discharge and the piston remains forced against the cylinder. Therefore, there the G-FLO pump no longer provides a passage. Its efficient cleaning can no longer be ensured and the cylinder/piston pair will become prematurely worn.

Authorised assembly :

As mentioned previously for applications where cleaning is easy, assembly in parallel is authorised when the valves are installed so that the cleaning pressure of the circuit does not come into contact with the G-FLO pump. In this case, the G-FLO pump cleans itself.

Cleaning the pump :

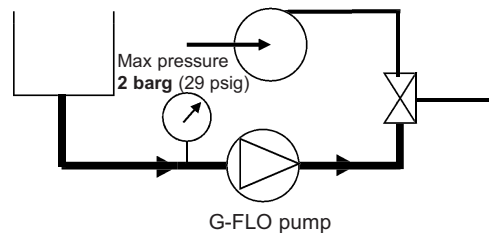

We recommend limiting the rotation speed of the G-FLO pump.

Cleaning the installation :

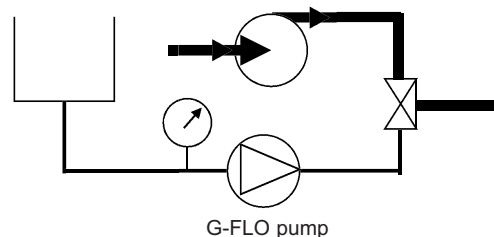

The G-FLO pump is stopped when cleaning the installation.

3. CLEAN IN PLACE (CIP) & STERILISATION IN PLACE (SIP) (continued)

3.5 Successive cycles

Generally, the most efficient CIPs comprise 5 stages :

1. Pre-washing with clean water

Water at room temperature. 10 to 15 minute cycle. This pre-wash enables evacuation of the remaining residues.

2. Washing with an alkaline detergent

Typically this is soda at 2,5% at a temperature of 80°C. 20 to 30 minute cycle. This wash particularly enables dissolving and evacuating grease and proteins.

3. Rinsing with clean water

Water at room temperature. 10 minute cycle. This rinse enables avoiding the mixture of 2 cleaning solutions.

4. Washing with an acid solution

Typically this is nitric acid at 2,5% at room temperature. 10 to 15 minute cycle. This wash particularly enables dissolving and evacuating proteins and inorganic salts.

5. Rinsing with clean water

Water at room temperature. Several 1 to 2 minute cycles. These rinses enable evacuating all traces of acid solution.

During all these CIP stages, the average speeds of the cleaning liquids in the pipes must be between 1,5 and 3 m/s.

3.6 Sterilisation In Place (SIP)

The G-FLO pumps are perfectly adapted to all processes using SIP (Sterilisation In Place) : pump stopped / maximum 30 min per cycle / 1 or 2 cycles per day.

4. MAINTENANCE

4.1 Tightened torques (N.m)



Standard version



Item	Part	FLO 6 S FLO 8 S	FLO 11 S FLO 15 S	FLO 25 S	FLO 40 S	FLO 50 S	FLO 65 S FLO 65 HP
39149	Screw	5	13	13	13	13	13
39304A	Screw	6,4	15,5	15,5	29	29	30
39304	Screw	4,3	30	30	26	60	60
39106	Nut	35	40	40	90	90	90
39115	Nut	35	40	100	160	160	160



HT version (High Temperature)



Item	Part	FLO 6 HT FLO 8 HT	FLO 11 HT FLO 15 HT	FLO 25 HT	FLO 40 HT	FLO 50 HT
39149	Screw	5	13	13	13	13
39304A	Screw	6,4	15,5	15,5	29	29
39304	Screw	4,3	30	30	26	60
39106	Nut	35	36	40	90	90
39115	Nut	35	40	90	160	160



5. OPENING OF THE PUMP



	WARNING	
		TAKE ALL NECESSARY MEASURES TO RENDER ANY START-UP, EVEN ACCIDENTAL, OF THE PUMP DURING THE WORK IMPOSSIBLE.
Any unforeseen start-up can cause serious injuries or important material damages.		



	WARNING	
		DISCONNECTING THE FLUID OR PRESSURE CONTAINMENT COMPONENTS DURING PUMP OPERATION CAN CAUSE SERIOUS PERSONAL INJURY, DEATH OR MAJOR PROPERTY DAMAGE.
Hazardous pressure can cause personal injury or property damage.		

	WARNING	
		FAILURE TO RELIEVE THE SYSTEM PRESSURE PRIOR TO PERFORMING ANY WORK ON THE PUMP OR THE INSTALLATION CAN CAUSE PERSONAL INJURY OR PROPERTY DAMAGE.
Hazardous pressure can cause personal injury or property damage.		

	WARNING	
		IF PUMPING HAZARDOUS OR TOXIC FLUIDS, THE SYSTEM MUST BE FLUSHED PRIOR TO PERFORMING ANY SERVICE OPERATION.
Hazardous or toxic fluids can cause serious injury.		

	WARNING	
		BE CAREFUL WITH THE WEIGHT OF THE PARTS WHEN THEY ARE BEING REMOVED.
The weight of the parts can be dangerous and may provoke bodily injuries or material damages.		

	CAUTION	
		THE PUMP LUBRICANT IS VERY SLIPPERY AND MAY CAUSE SERIOUS INJURY. ANY SPILLS MUST BE CLEANED UP.
Slippery lubricant. Spills should be cleaned up.		

	CAUTION	
		THE SURFACES CAN BE AT A TEMPERATURE LIABLE TO CAUSE INJURY OR SEVERE DAMAGE.
Excessive temperature can cause injury or severe damage.		

Before any dismantling, make sure that the pump has been drained and take the necessary measures to avoid starting-up. No start-up, even accidental, must be allowed.

5. OPENING OF THE PUMP (continued)

5.1 Assembly / dismantling FLO 6 - FLO 8

- Disconnect the pump from the discharge pipe.
- Unscrew the 4 blind nuts 39106 and remove them.
- Remove the front cover 39401 and its seal 39205.

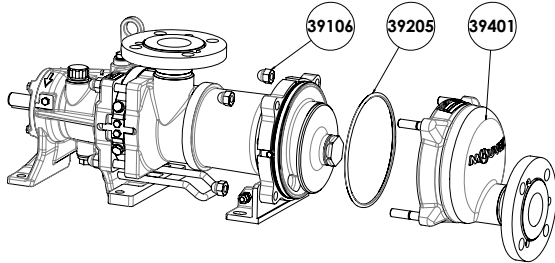

- Unscrew the piston nut 39304 and its seal 39305.
- Unscrew the 5 screws 39304A.

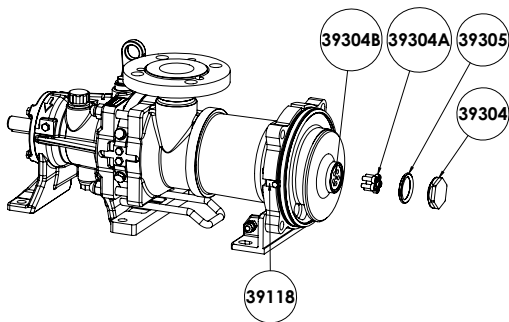

- Remove the piston 39301 and its seal 39305 screwing the extraction screws 39304B.

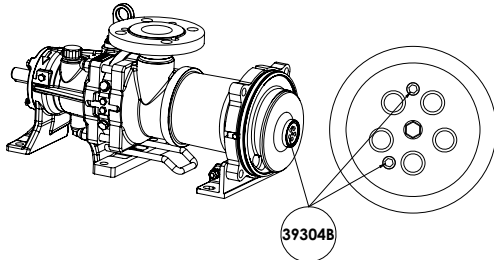

- If the 39304B jackscrews do not allow the piston to be extracted, take 3 screws of the same diameter as the 39304A screws but having an additional thread length equal to at least 3 times the nominal diameter of the screws.

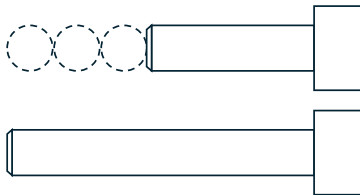

- Screw in these screws to the bottom of the thread but do not tighten them. Tap the screw heads with a mallet until the piston is extracted.

- Unscrew the 4 screws 39149.
- Remove the cylinder 39201 and its seals 39113A.

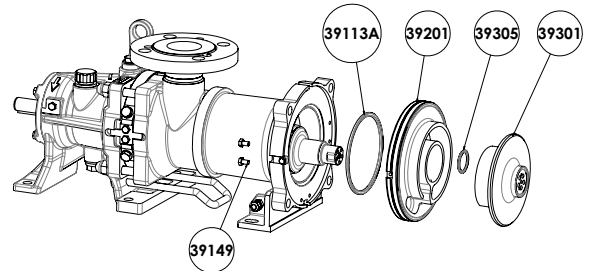

- Unscrew and recover the indexer 39118 to use it during the next assembly of the cylinder/piston set.

5. OPENING OF THE PUMP (continued)

5.2 Assembly / dismantling FLO 11 to FLO 65

- Disconnect the pump from the discharge pipe.
- Unscrew the 8 blind nuts 39106 and remove them.
- Remove the front cover 39401 and its seal 39205.

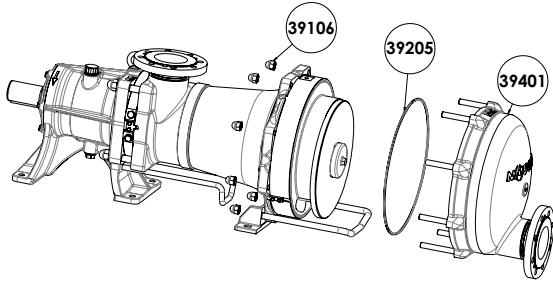

- To make handling of the cylinder/piston unit easier, move the lifting ring from the transmission body to the cylinder.

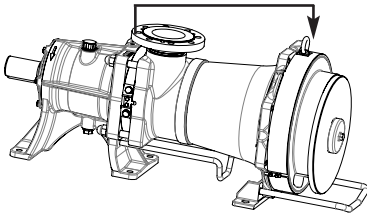

- Unscrew the piston nut 39304 and its seal 39305.
- Unscrew the screws 39304A.

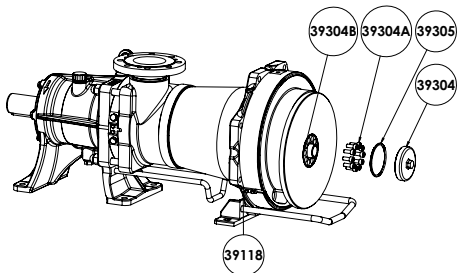

- Remove the piston 39301 and its seal 39305 screwing the extraction screws 39304B.

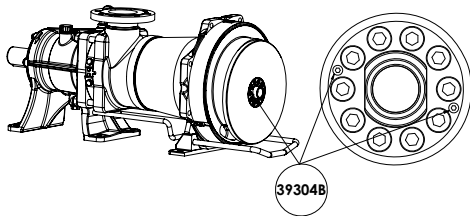

- Unscrew the 4 screws 39149.
- Remove the cylinder 39201 and its seals 39113A.

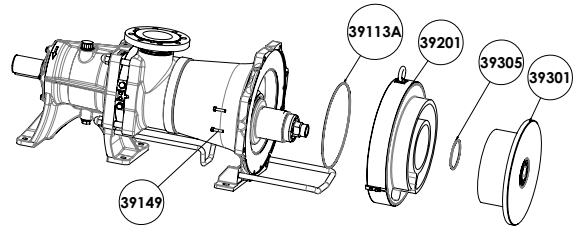

- Unscrew and recover the indexer 39118 to use it during the next assembly of the cylinder/piston set.

5. OPENING OF THE PUMP (continued)

5.3 Checking of cylinder and piston

The piston 39301 and the cylinder 39201 are active parts (wearing parts) on which the pump's efficiency directly depends. It is therefore advisable to regularly check the pump's efficiency and replace the cylinder / piston if it decreases.

In addition, as using a cylinder / piston that is too worn may damage the pump's transmission system. It is therefore advisable to replace the cylinder / piston.

- Remove the front cover. See § OPENING OF THE PUMP - ASSEMBLY / DISMANTLING.
- Check the cleanliness of the cylinder and piston reference surfaces (no deposits or residue ; remove them if necessary).
- Rotate the shaft to place the piston in the lowered position.

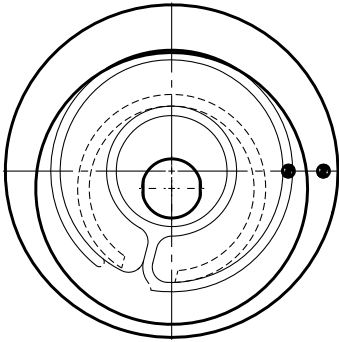

- Measure the distance between the piston and cylinder reference surfaces. The use of a depth gauge is recommended for this measurement.

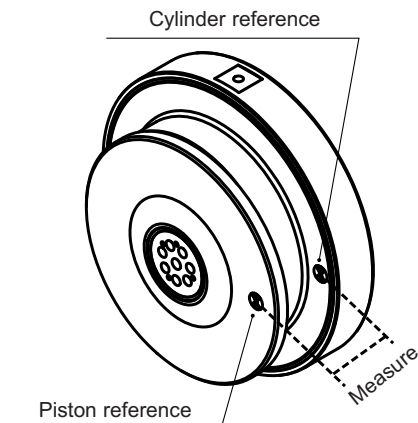

- Compare the measurement to the dimensions defined in the table below.

Checking dimensions (mm)

Pump	New dimension	Allowed wear	Minimum dimension acceptable
FLO 6	15,95 (0,628)	4 (0,157)	11,95 (0,470)
FLO 8	24,39 (0,960)	4 (0,157)	20,39 (0,803)
FLO 11	24,3 (0,957)	6 (0,236)	18,30 (0,720)
FLO 15	34,30 (1,350)	6 (0,236)	28,30 (1,114)
FLO 25	46,29 (1,822)	6 (0,236)	40,29 (1,586)
FLO 40	55,98 (2,204)	6 (0,236)	53,98 (2,125)
FLO 50	58,40 (2,299)	6 (0,236)	52,40 (2,063)
FLO 65 S	73,00 (2,874)	6 (0,236)	67,00 (2,638)
FLO 65 HP	71,40 (2,811)	6 (0,236)	65,40 (2,575)

5. OPENING OF THE PUMP (continued)

5.4 Checking cylinder / piston set in case of disassembly

It is advisable to replace the cylinder / piston if the maximum acceptable wear dimensions defined in the table below are reached.

		Piston 39301 (mm)	Cylinder 39201 (mm)
FLO 6 S	New dimension	5,46 (0,215)	29,47 (1,160)
	Minimum wear dimension acceptable	3,46 (0,136)	27,47 (1,081)
FLO 8 S	New dimension	5,9 (0,232)	37,47 (1,475)
	Minimum wear dimension acceptable	3,9 (0,154)	35,47 (1,396)
FLO 11 S	New dimension	10,3 (0,406)	49,47 (1,948)
	Minimum wear dimension acceptable	7,3 (0,288)	46,47 (1,830)
FLO 15 S	New dimension	10,3 (0,406)	59,47 (2,341)
	Minimum wear dimension acceptable	7,3 (0,288)	56,47 (2,223)
FLO 25 S	New dimension	12,79 (0,504)	78,0 (3,074)
	Minimum wear dimension acceptable	9,79 (0,385)	75,0 (2,956)
FLO 40 S	New dimension	16,47 (0,648)	106,0 (4,174)
	Minimum wear dimension acceptable	13,47 (0,530)	103,0 (4,056)
FLO 50 S	New dimension	15,9 (0,625)	101,7 (4,004)
	Minimum wear dimension acceptable	12,9 (0,507)	98,7 (3,886)
FLO 65 S	New dimension	17,5 (0,689)	125,3 (4,932)
	Minimum wear dimension acceptable	14,5 (0,570)	122,3 (4,813)
FLO 65 HP	New dimension	15,9 (0,625)	125,3 (4,932)
	Minimum wear dimension acceptable	12,9 (0,507)	122,3 (4,813)

As changes in the pump's efficiency depend on the conditions of use (pressure, rotation speed, liquid pumped, etc.), MOUVEX recommends that users define the monitoring ranges and the preventive maintenance schedule according to their own experience.

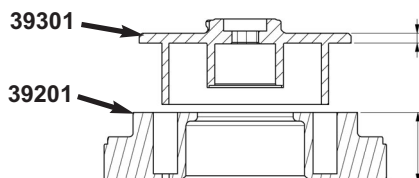

When controlling the piston and even if it has not reached its minimum dimensions, it may show following aspects, especially on abrasive liquid pumping or low viscosity :

- Triangular shape on top of piston wall (A),
- Small steps at piston wall base (B).

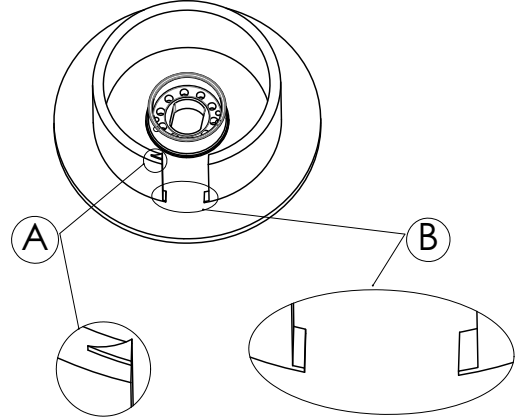

Before putting back the piston on the pump, eliminate these asperities by filing and finishing with fine sandpaper (No 320 grain or equivalent), taking care of not scratching any other surface around. Piston must then look as follows :

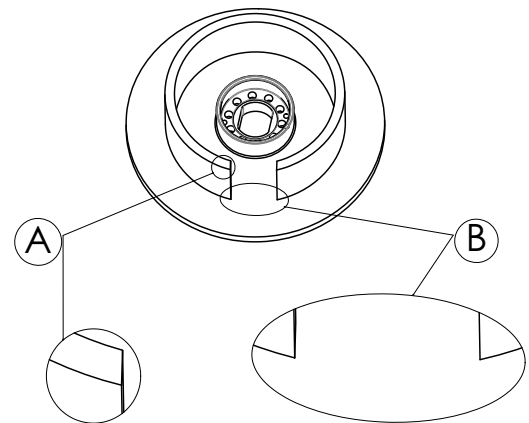



Do not retouch any other surface of the piston by any mean as it can degrade pump performance and reliability. In particular, do not round or attenuate disc wall edges.

Even if it shows wearing signs, do not retouch any surface of the cylinder by any mean as it can degrade pump performance and reliability.

6. ASSEMBLY OF CYLINDER/PISTON

6.1 FLO 6 - FLO 8

 Carefully clean the screws and nuts to remove any trace of thread lock.

	WARNING
	BE CAREFUL WITH THE WEIGHT OF THE PARTS WHEN THEY ARE BEING REMOVED.
The weight of the parts can be dangerous and may provoke bodily injuries or material damages.	

- Check the state of the seals 39113A and 39306, replace them if necessary.
- Position the seal 39113A on the main body and the seal 39306 on the hub.
- Position the hub downwards by turning the end of the drive shaft.
- Position the cylinder 39201 on the main body, check the alignment of the indexer 39118 with the notch on the main body and screw the 4 screws 39149 with thread locking adhesive (Loctite® 243* or equivalent), tightening torque : see § MAINTENANCE - TIGHTENED TORQUES.
- Position the hub upwards by turning the end of the drive shaft.
- Apply thread locking adhesive (Loctite® 222* or equivalent) to mount the 39304B screws and ensure that they do not protrude from the two ends of the thread.
- After making sure the piston / hub flat faces are aligned, engage the piston 39301 on the hub and the cylinder 39201 by applying a simultaneous downward effort.
- Keep the cylinder/piston set in place.
- Screw back the 5 screws 39304A with thread locking adhesive (Loctite® 243* or equivalent), tightening torque : see § MAINTENANCE - TIGHTENED TORQUES.
- Check the state of the seal 39305 (replace it if necessary) and position it on the piston nut 39304.
- Re-mount the piston nut 39304 with thread locking adhesive :
 - standard pumpLoctite® 222* or equivalent
 - HT pumpLoctite® 243* or equivalent
 Tightening torque : see § MAINTENANCE - TIGHTENED TORQUES.
- Re-mount the front cover 39401 with its seal 39205.
- Re-mount the 4 blind nuts 39106 with thread locking adhesive (Loctite® 243* or equivalent), tightening torque : see § MAINTENANCE - TIGHTENED TORQUES.

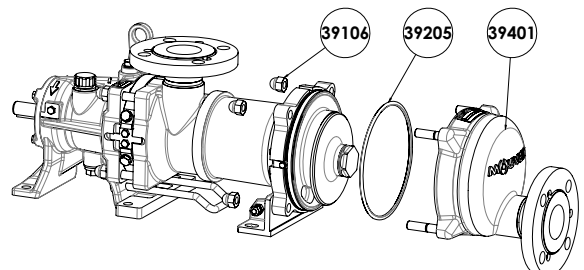
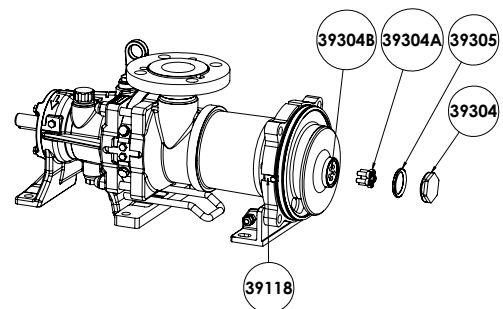
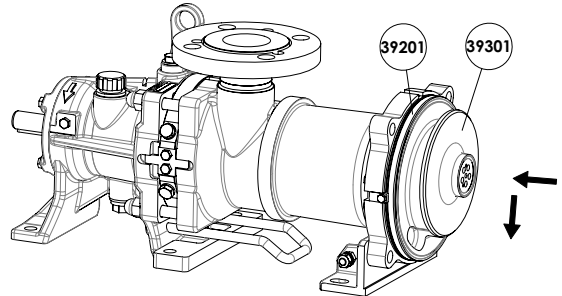
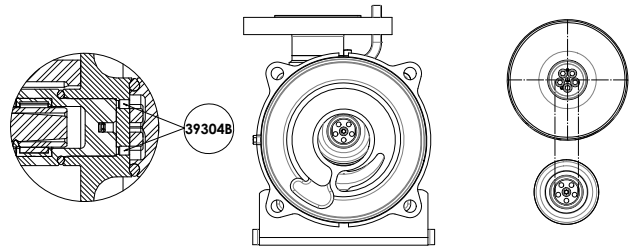
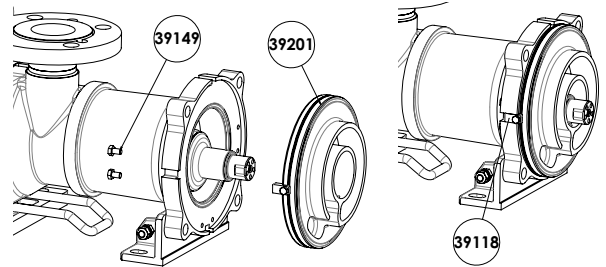
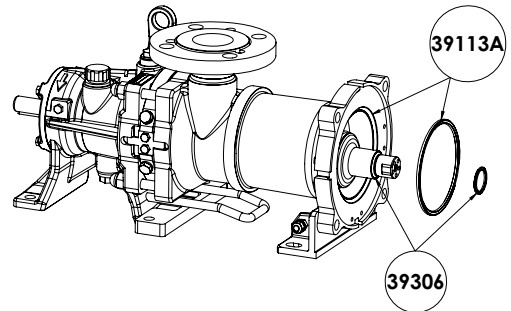

* Loctite® is a registered trademark.

6. ASSEMBLY OF CYLINDER/PISTON (continued)

6.2 FLO 11 to FLO 65



Carefully clean the screws and nuts to remove any trace of thread lock.



WARNING



BE CAREFUL WITH THE WEIGHT OF THE PARTS WHEN THEY ARE BEING REMOVED.

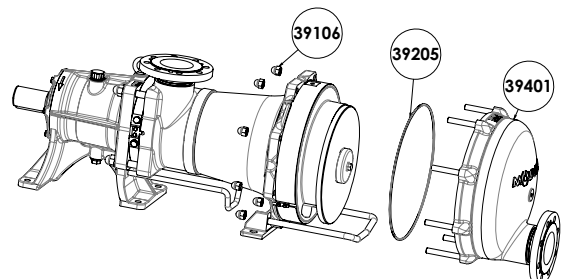
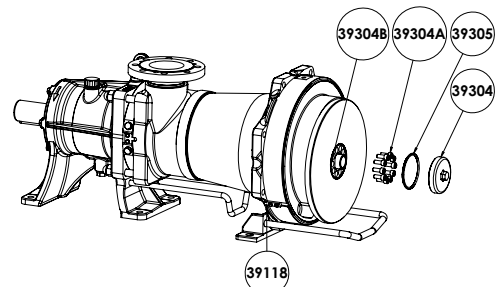
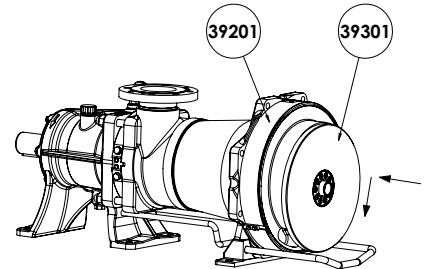
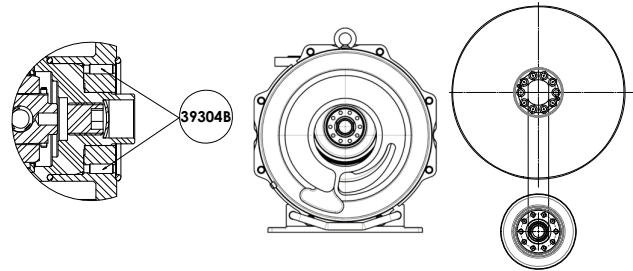
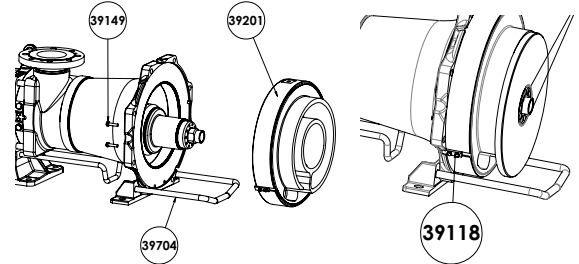
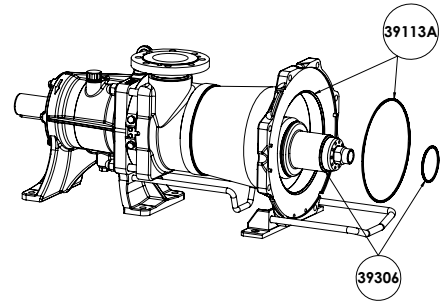

The weight of the parts can be dangerous and may provoke bodily injuries or material damages.

- Check the state of the seals 39113A and 39306, replace them if necessary.
- Position the seal 39113A on the main body and the seal 39306 on the hub.
- Position the hub downwards by turning the end of the drive shaft.
- Position the cylinder 39201 on the main body, check the alignment of the indexer 39118 with the notch on the main body and screw the 4 screws 39149 with thread locking adhesive (Loctite® 243* or equivalent), tightening torque : see § MAINTENANCE - TIGHTENED TORQUES.
- Position the hub upwards by turning the end of the drive shaft.
- Apply thread locking adhesive (Loctite® 222* or equivalent) to mount the 39304B screws and ensure that they do not protrude from the two ends of the thread.
- After making sure the piston / hub flat faces are aligned, engage the piston 39301 on the hub and the cylinder 39201 by applying a simultaneous downward effort.
- Keep the cylinder/piston set in place.
- Screw back the 10 screws 39304A with thread locking adhesive (Loctite® 243* or equivalent), tightening torque : see § MAINTENANCE - TIGHTENED TORQUES.
- Check the state of the seal 39305 (replace it if necessary) and position it on the piston nut 39304.
- Re-mount the piston nut 39304 with thread locking adhesive :
 - standard pumpLoctite® 222* or equivalent
 - HT pumpLoctite® 243* or equivalent
 Tightening torque : see § MAINTENANCE - TIGHTENED TORQUES.
- Re-mount the front cover 39401 with its seal 39205.
- Re-mount the 8 blind nuts 39106 with thread locking adhesive (Loctite® 243* or equivalent), tightening torque : see § MAINTENANCE - TIGHTENED TORQUES.



* Loctite® is a registered trademark.

7. CHANGING THE LIP SEAL

 CAUTION	
	
THE PUMP LUBRICANT IS VERY SLIPPERY AND MAY CAUSE SERIOUS INJURY. ANY SPILLS MUST BE CLEANED UP.	
Slippery lubricant. Spills should be cleaned up.	

- Drain the pump bearing (see § DRAINING OF BEARING).
- Unscrew the screws 39609.
- Remove the cover 39607 and the seals 39608, 39608A and 39602.
- If the seal face is marked, change the ring 39507.

- Extract the 2 lip seals 39608 and 39608A.
- Fit 2 new seals 39608 and 39608A, one on each side of the cover, lip directed towards the interior of the transmission.
- Greasing the lips of the seals and greasing between the 2 seals 39608 and 39608A.
- Re-mount the cover 39607 after placing the seal 39602.

	FOOD SYNTHETIC GREASE : Compulsory reference because compatible with the standard MOVEX bearing oil.
---	---

- After replacing the drain plug, fill the bearing with oil* (see § DRAINING OF BEARING).
- Screw back the breather 39715.

FLO 6 - 8

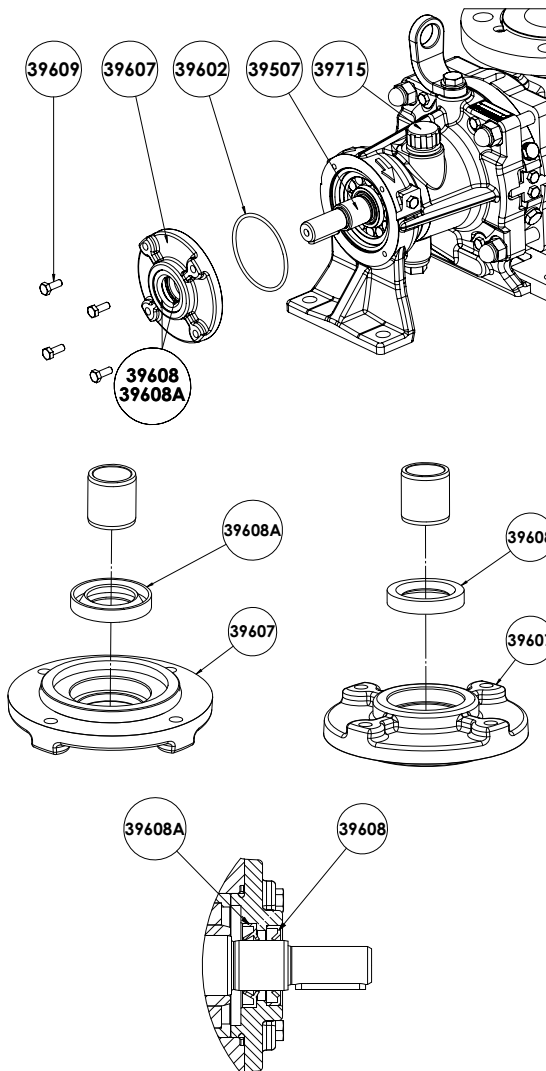

FLO 11 - 15 - 25 - 40 - 50 - 65

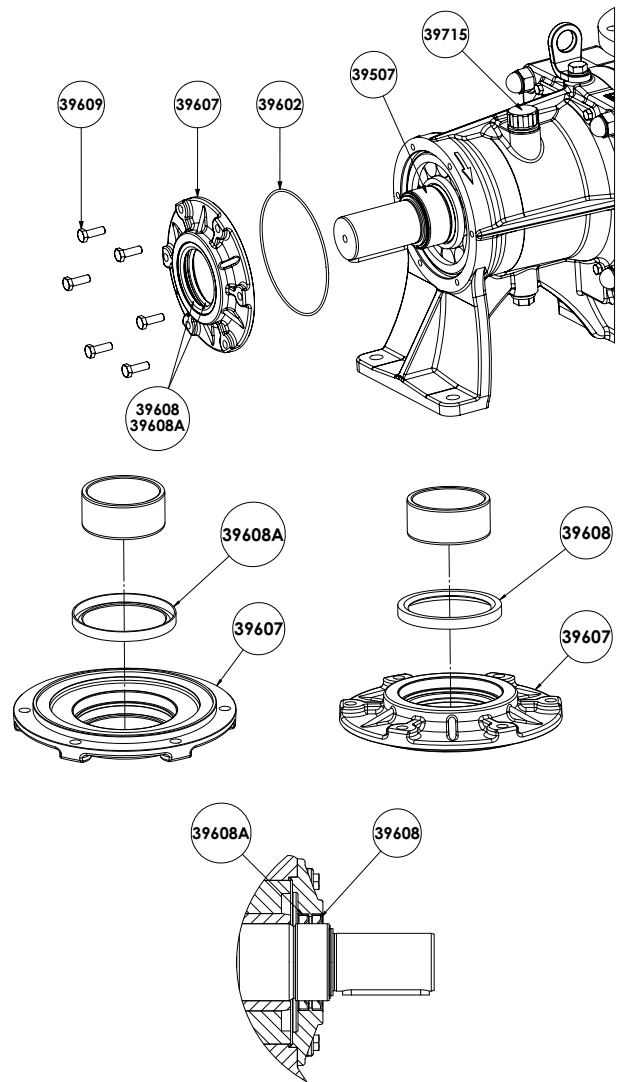



* Standard oils provided by MOVEX (Safety data sheet is supplied on inquiry) :

CS05 Food synthetic oil
 CS23 Silicone free oil for transmission

* Other oil provided by customer.

8. CHANGING THE ORIENTATION OF THE PORTS

 WARNING	BE CAREFUL WITH THE WEIGHT OF THE PARTS WHEN THEY ARE BEING REMOVED.
	
<p>The weight of the parts can be dangerous and may provoke bodily injuries or material damages.</p>	

	<p>Carefully clean the screws and nuts to remove any trace of thread lock.</p>
---	---

8.1 Discharge port

- Unscrew the nuts 39106.
- Turn the front cover 39401 so as to position the outlet port in the desired position.
- Screw back the nuts 39106 with thread locking adhesive Loctite® 243* or equivalent. Tightening torque : see § MAINTENANCE - TIGHTENED TORQUES.
- Make sure that the seal 39205 is secured in its housing. Secure it with a grease that is compatible with the transferred product if necessary.

8.2 Suction port

- Remove the front cover and the set cylinder/piston. See § OPENING OF THE PUMP.
- Remove the support assembly (39109+39108+39704A) by unscrewing the 2 screws 39109.
- Unscrew the 4 nuts 39115.
- Turn the main body 39101 so as to position the outlet port in the desired position.
- Screw back the 4 nuts 39115 with thread locking adhesive Loctite® 243* or equivalent. Tightening torque : see § MAINTENANCE - TIGHTENED TORQUES.
- Make sure that the seal 39113 is secured in its housing. Secure it with a grease that is compatible with the transferred product if necessary.

FLO 6 - 8

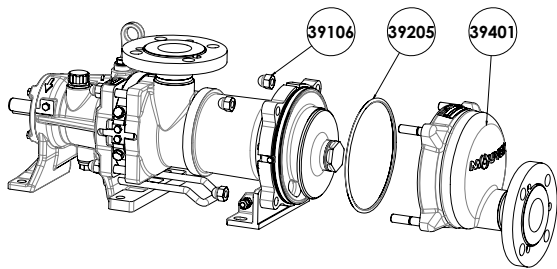

FLO 11 - 15 - 25 - 40 - 50 - 65

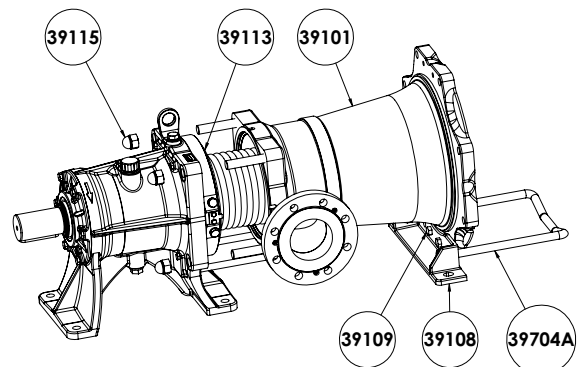
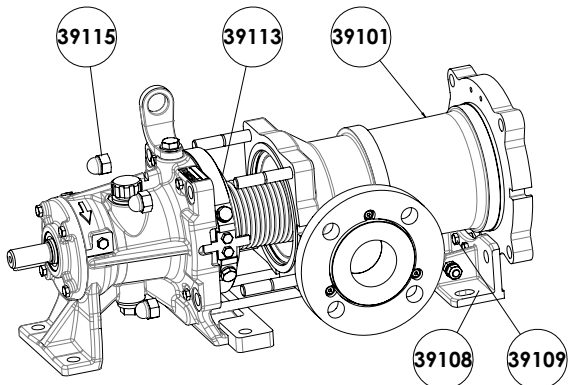
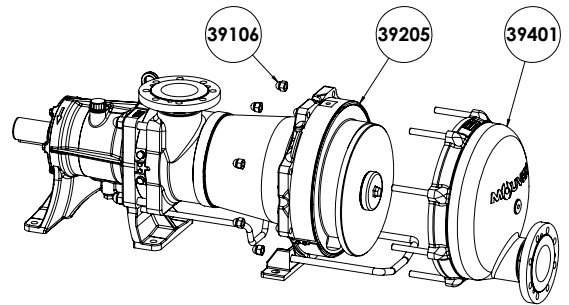

* Loctite® is a registered trademark.

8. CHANGING THE ORIENTATION OF THE PORTS (continued)

8.3 Flanges dismantling

- Remove the three screws 39136.

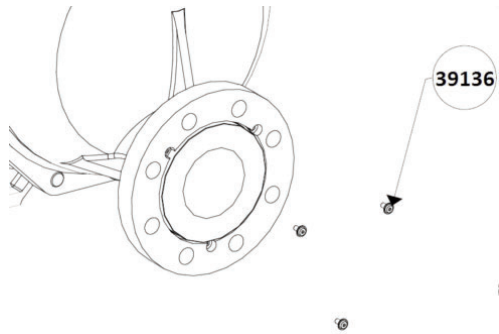

Push back flange 39114 against manifold or end cover.

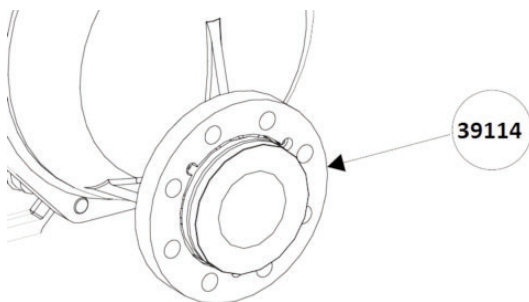

- Remove ring 39148 from manifold or end cover groove.

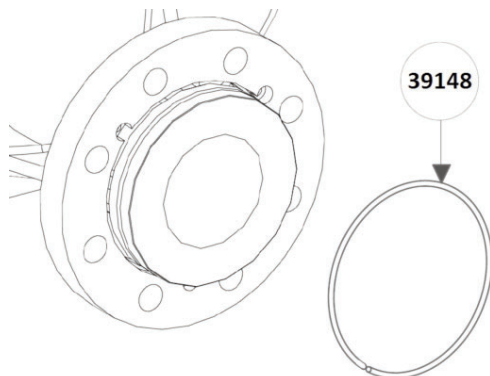





8.4 Flanges reassembly

- Put flange 39114 against manifold or end cover with the three counter-bores visible.
- Put ring 39148 in manifold or end cover groove (it should take its place thanks to its elasticity).
- Pull flange 39114 until ring 39148 is no longer visible.
- Put three screws 39136 and tight them with Loctite® 243* thread lock or equivalent.
- Orientate flange to match counter flange holes position (flange must rotate freely).

* Loctite® is a registered trademark.

9. DRAINING OF BEARING

	CAUTION	<p>THE SURFACES OF THE PUMP AND OIL TRANSMISSION CAN BE AT A TEMPERATURE LIABLE TO CAUSE INJURY OR SEVERE DAMAGE.</p>
		
<p>Excessive temperature- can cause injury or severe damage.</p>		

	CAUTION	<p>THE PUMP LUBRICANT IS VERY SLIPPERY AND MAY CAUSE SERIOUS INJURY. ANY SPILLS MUST BE CLEANED UP.</p>
		
<p>Slippery lubricant. Spills should be cleaned up.</p>		

- Drain the transmission following the board below :

Standard pump :

- Data with **MOVEX Standard oil CS05*** :

Temperature of product pumped / heating product	Draining interval (running hours)
$80\text{ °C} < T \leq 100\text{ °C}$	12 000
$T \leq 80\text{ °C}$	24 000

- Data with **MOVEX Silicone free oil CS23*** :

Temperature product pumped / heating product	Draining interval (running hours)
$T < 100\text{ °C}$	5 000

- Data with **other customer oil** : the drawing interval is defined by the customer (tests results) regarding the oil specifications and the pump conditions.

HT pump :

- Data with **MOVEX Standard oil CS05*** :

Temperature product pumped / heating product	Draining interval (running hours)
$150\text{ °C} < T \leq 160\text{ °C}$	800
$135\text{ °C} < T \leq 150\text{ °C}$	1 500
$120\text{ °C} < T \leq 135\text{ °C}$	3 000
$100\text{ °C} < T \leq 120\text{ °C}$	6 000

- Drain the pump by removing the drain plug with its seal 39773-39774 and the breather 39715.
- Replace the drain plug and its seal.

- Fill the transmission with oil*.

Indicative oil volume (liters \pm 10%) :

- Pump without ECS :

Pump	FLO 6/8	FLO 11/15	FLO 25	FLO 40	FLO 50	FLO 65
Oil volume	0,4	1	1,5	2	2,5	4

- Pump with ECS :

Pump	FLO 6/8	FLO 11/15	FLO 25	FLO 40	FLO 50
Oil volume	0,9	2,25	3,2	4,1	5,1

See Instructions NT 1011-W00 ECS SYSTEM SERIE G_H FLO.

- Oil level : Any level visible in the height of oil level indicator 39772B is acceptable. On HT (High Temperature pumps), oil can change to dark color making level hardly visible. If so, unscrew slightly the oil level indicator 39772B. If oil flows out, level is acceptable. **DO NOT PROCEED THIS CONTROL WHEN PUMP IS RUNNING AND/OR HOT.**

- Screw back the breather 39715.

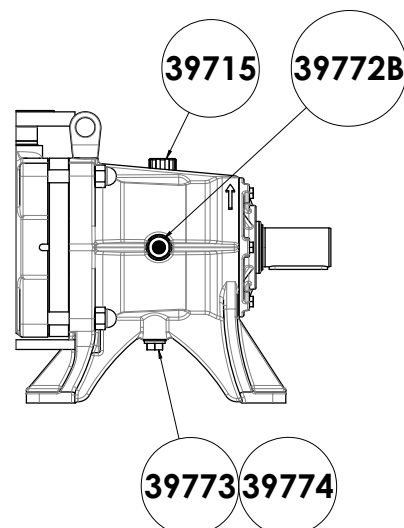

* **Standard oils provided by MOVEX** (Safety data sheet is supplied on inquiry) :



- CS05 Food synthetic oil
- CS23 Silicone free oil for transmission

* **Other oil provided by customer.**

10. STORAGE

If necessary, refer to § OPENING OF THE PUMP for pump disassembly.

10.1 Short duration (≤ 1 month)

	WARNING
	IF PUMPING HAZARDOUS OR TOXIC FLUIDS, THE SYSTEM MUST BE FLUSHED PRIOR TO PERFORMING ANY SERVICE OPERATION.
Toxic or hazardous fluids can cause serious injury.	

MOUVEX pumps and motor-driven pumps are well lubricated when delivered to protect the internal parts during brief storage in a building where :

- the temperature remains between 10°C and 50°C.
- the relative humidity does not exceed 60%.
- exposure to vibration is limited.
- pump is stored in an area sheltered from bad weather and sun.

10.2 Long duration (> 1 month)

The recommendations from the manufacturer should be followed if the pump is stored with its gear motor.

Pump ports should be filled with a non-corrosive liquid that it compatible with the pump components in order to prevent corrosion.

Unpainted external surfaces of the pump (e.g. shafts, couplings, etc.) should be covered in some form of anti-corrosion protection.

If storage was made after a period of operation, the transmission oil must be replaced before storage (see § DRAINING OF BEARING).

The transmission will be filled with oil at breather level (see § DRAINING OF BEARING).

If pump storage lasted more than one year, the oil should be replaced in time to prevent an excessive degradation of its qualities.

The best storage conditions are inside a building that meets the conditions set out above.

If inside storage is not possible, the materials should be covered to prevent direct exposure to sun and bad weather. This protection should also prevent condensation.

The pump should be turned a few revolutions manually every two months.

10.3 Restarting

Follow the standard start-up procedure for the pump/ motor-driven pump, as well as the instructions below.

Turn the pump by hand to make sure the parts move freely.

If the storage duration has exceeded one year, replace the oil transmission (see § DRAINING OF BEARING for removal instructions).

If the pump has a safety bypass, remove it and inspect the parts and make sure they move freely.

In all cases, the oil should be replaced after more than two years after its commissioning.

11. TROUBLESHOOTING

ZERO OR INSUFFICIENT FLOW		
1		PRELIMINARY CHECKS
	1-1	Make sure that the plastic plugs have been taken away from the ports of the pump and that the pump is running (defective drive, damaged motor, etc., faulty transmission : broken coupling, sliding belt, worn or poorly coupled clutch, etc.).
	1-2	Make sure that the pump rotates in the correct direction corresponding to the direction in which the liquid circulates in the installation (cf. the pump plate). If necessary, change the electric motor connections.
	1-3	Make sure that the pump rotation speed is sufficient. Determine this by checking the speed of the pump motor (see motor plate) and the speed reduction ratio (see reduction gearbox plate) or use a rev. counter.
		If these checks do not highlight the problem :
2		MEASURE THE DISCHARGE PRESSURE (as close to the outlet of the pump as possible, with a minimum distance of 5 pipe diameters).
	2-1	If the pressure is lower than the figures given for the material, or null, this could be due to :
	2-1-1	The pump is worn, this will also affect the suction capacity of the pump (cf 3-2-2 b).
3		MEASURING THE VACUUM PRESSURE (as close as possible to the pump inlet, inlet side).
	3-1	If the vacuum is high, e.g. higher than or equal to 6 to 7 metres WC (0.6 to 0.7 bara i.e. about 45 or 50 cm of mercury), this can result in pump noise. The cause could be :
	3-1-1	a. the suction lift is too high (reduce it by taking the pump down closer to the level of the liquid). b. the dynamic suction losses are too high : the inlet piping orifice is too close to the bottom of the tank.
	3-1-2	The inlet piping is completely blocked (valve, tap, filter, cloth, full seal forgotten, etc.)
	3-1-3	The liquid vapour pressure is too high (or has become too high following, for example, a change of temperature). Bring the pump closer to the level of the liquid, install the pump closer to the feed or cool the liquid to reduce the vapour pressure.
	3-2	If the vacuum is low, for example, less than 3 metres WC (i.e. about 20 cm of mercury), check for leaks on the inlet pipe, isolate the pump from the inlet piping (by closing the valve nearest the pump or by inserting a full flange seal) and measuring the vacuum once again.
	3-2-1	If the vacuum is high with the isolating valve closed on suction line, e.g. higher than or equal to 6 or 7 metres WC (i.e. about 45 to 50 cm of mercury), the pump is not the cause : a. there must be an air inlet upstream of the pump isolating valve. b. the liquid vapour pressure is or has become too elevated due to a change of temperature (cf 3-1-3).
	3-2-2	If the vacuum is low or non-existent, the reason could be : a. air is entering the pump (check the front cover seals, flanges, etc...) b. the pump is worn and the internal tightness is out of specification (the piston bushings are worn, worn piston and cylinder, broken piston wear compensation springs, worn partition, broken shaft).

11. TROUBLESHOOTING (continued)

ABNORMAL HEATING OF BEARINGS			
4			This heating can be caused by :
	4-1		- excessive tension in the transmission (belt or chain) on the pump shaft.
	4-2		- excessive pulling on the pump flanges by the piping (in this case, it must have been necessary to force the piping into position to connect it to the pump).
	4-3		- poor alignment of the pump - due for example to 4-2 (the pump is partially or totally uncoupled, the pump shaft and drive shaft are not aligned with each other).
	4-4		- inadequate anchoring of the pump unit leading to deformation of the chassis (make sure that the chassis is clear of the ground except for the 3 anchoring points).
ABNORMAL NOISES			
			These noises can be caused by hydraulic and mechanical sources. They can be distinguished by the fact that only the former disappear (or at least lessen) when air is allowed into the inlet pipe.
5			HYDRAULIC NOISES
			These noises can come from insufficient product being supplied to the pump, or :
	5-1		- the rotation speed is too high for the installation conditions (increase of viscosity due to a change of product or a reduction of temperature, etc.).
	5-2		- that the suction head is too high or has become too high due to excessive head losses following clogging of the piping or filter, a change of viscosity of the liquid, etc.,
	5-3		- an increase of the vapour pressure with a rise of temperature.
6			MECHANICAL NOISES
			These can stem from :
	6-1		- abnormal stress on the pump : the transmission is pulling on the shaft, pulling on the flanges by the piping.
	6-2		- a broken part or foreign body has entered the pump.
EXCESS POWER CONSUMPTION			
7			The most spectacular event occurs when the power to an electric motor is shut off.
	7-1		If this incident occurs when closing the discharge line, the cause may be the motor protection is adjusted too low or wrong circuit breaker have been fitted.
	7-2		If the incident occurs during operation, the cause could be : a. an inadequate motor (in this case, the discharge pressure complies with what was expected). b. head losses higher than expected - following higher viscosity or specific gravity than planned initially (in this case, the discharge pressure is higher than that planned. The pressure can be reduced by loosening the relief valve adjustment screw - the flow is decreased). c. excessive speed of rotation. d. a fault of the equipment (faulty alignment, deformation of the chassis, stress exerted by the piping on the flanges, seizing, etc.).
			Excessive consumption of electricity can also be due to a poor motor connection (e.g. a 3 phase motor operating on 2 phases).