



INSTRUCTIONS 1011-L00 e

Section	1011
Effective	October 2018
Replaces	June 2004

Original instructions

Couplings

ASSEMBLY

DISASSEMBLY



This MOUVEX Instructions provides assistance for installation but it is not, in any circumstances, intended to replace the specific Instructions of the relevant equipment suppliers. Those Instructions must be read before fitting the equipment.



Z.I. La Plaine des Isles - F 89000 AUXERRE - FRANCE
Tel. : +33 (0)3.86.49.86.30 - Fax : +33 (0)3.86.49.87.17
contact@mouvex.com - www.mouvex.com

Your distributor :

ASSEMBLY / DISASSEMBLY

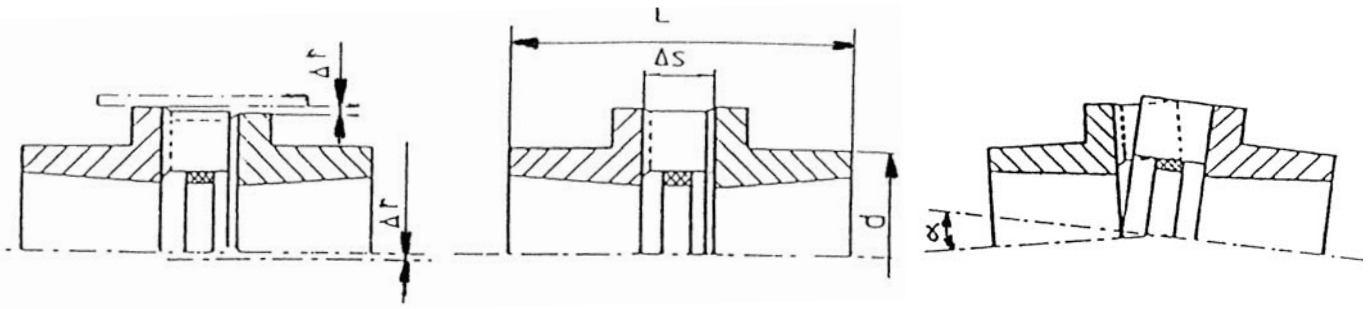

Maximum figures for out-of-line

dia mm	Size	Misalignment radial $-\Delta r$ mm	Misalignment axial $-\Delta s$ mm		Misalignment angular α
			L	+0+	
60	HRC 70	0,3	65	+ 0,2	1° maxi
70	HRC 90	0,3	69,5	+ 0,5	1° maxi
100	HRC 110	0,3	82	+ 0,6	1° maxi
105	HRC 130	0,4	89	+ 0,8	1° maxi
115	HRC 150	0,4	107	+ 0,9	1° maxi
125	HRC 180	0,4	142	+ 1,1	1° maxi
155	HRC 230	0,5	164,5	+ 1,1	1° maxi

Instructions for assembly

Test the motor's direction of rotation before coupling it.

Assembly

- Remove the protective coating bore hole, from outside the hub and from the bore hole in the flange.
Ensure that the conical contact surfaces are perfectly clean, with neither oil nor dirt and then insert the hub in the flange while lining up the fastening holes (the smooth half-holes in the hub opposite the threaded half-holes in the flange).
- Oil lightly the threads and the ends of the wormscrews, or the threads and the under of the heads assembly screws. Fit the screws in the threaded holes of the hub represented by ● in the diagram opposite.
- Clean the shaft and slide the flange/hub assembly on it as far as the correct position. Do not forget that the hub first tightens on the shaft, then draw the flange lightly into place on the hub.
- When using a key, place it in the slot before mounting the hub.
The key must have parallel edges with insertion at the side only and with a clearance AT THE TOP.
- Using a hexagonal wrench, tighten the screws gradually and alternately to the torque indicated in the table.
- Tap on the widest end of the hub with a mallet, inserting a sleeve or chock to prevent damage to the hub, and to ensure that the hub is correctly fitted in the hole. Then, tighten the screws a little more. Repeat this operation once or twice for maximum tightness on the shaft.

- Operate the transmission system under load for a little time and then check that the screws are tight.
- Fill the holes with grease to prevent dust entering.

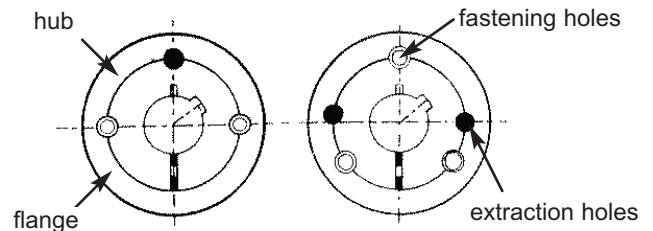

Holes are as follows depending on the coupling type :

- 2 fastening holes and 1 extraction hole
- 3 fastening holes and 2 extraction holes

Disassembly

- Screw out all the screws by several turns, remove one or two screws, depending on the number of extraction holes (this number varies with the size of the coupling) illustrated by ● on the diagram (the threaded half-hole in the hub and the smooth half-hole in the flange).
Insert the screw(s) in the hole(s) after oiling the threads and the ends of the wormscrews, or the threads and the underpart of the heads of the assembly screws.
- Tighten the extraction screw(s) alternately until the hub emerges from the flange and the whole assembly is free on the shaft.
- Withdraw the shaft.