



INSTRUCTIONS 1005-C00 e

Section	1005
Effective	April 2023
Replaces	September 2018

Translation of the original instructions

Pump AF TM H

INSTALLATION

OPERATION

MAINTENANCE

EC CERTIFICATE OF CONFORMITY :

The EC Certificate of Conformity (paper version) is systematically attached to the equipment when shipped.

WARRANTY :

TM Series pumps are covered 24 months by warranty within the limits mentioned in our General Sales Conditions. In case of a use other than that mentioned in the Instructions manual, and without preliminary agreement of MOUVEX, warranty will be canceled.



Z.I. La Plaine des Isles - F 89000 AUXERRE - FRANCE
Tel. : +33 (0)3.86.49.86.30 - Fax : +33 (0)3.86.49.87.17
contact.mouvex@psgdover.com - www.mouvex.com

Your distributor :

INSTALLATION

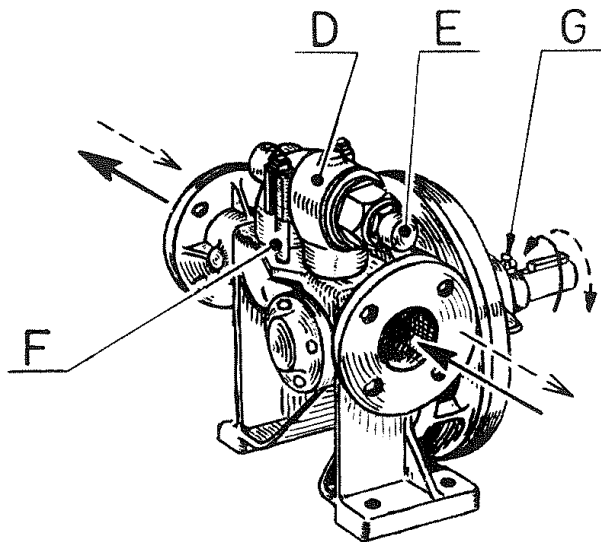

- D : Bypass
- E : Bypass cap
- F : Fixing stud and nut
- G : Bearing nipple

Piping assembly

For hoses fitting on pump suction or discharge, a hose whip restrain device must be installed to limit the whip or travel of the pressurized hose at start up, or in case the hose breaks free.



WARNING :
SEVERE PERSONAL INJURY OR PROPERTY DAMAGE
CAN CAUSE FROM WHIPPING HOSES.

Rotation

MOUVEX pump is reversible. Suction and discharge ends are bound to rotation as indicated on plate fixed to pump.

Motor protection

As the bypass protects the pump only, electric motors should be equipped with their own protection device.

Bypass orientation

Operation

Acting as a relief valve, the bypass protects pump and auxiliary equipment from damage due to excessive pressures that may be built up when the pump runs against some obstruction in the discharge piping.

When discharge pressure reaches the pressure limit for which the bypass is set, valve **803** opens and thus allows the liquid to be circulated from the discharge side back to the suction side.

Orientation

The single bypass protects the pump in one direction of rotation only.

Therefore make sure it is rightly installed by checking that bypass cap is on the suction side and reverse bypass if necessary.

Reversing

To reverse bypass, remove studs **814** and rotate bypass body by 180°.

Check centering gaskets **877**.

Tighten studs **814** taking care to keep bypass on end.

UTILISATION

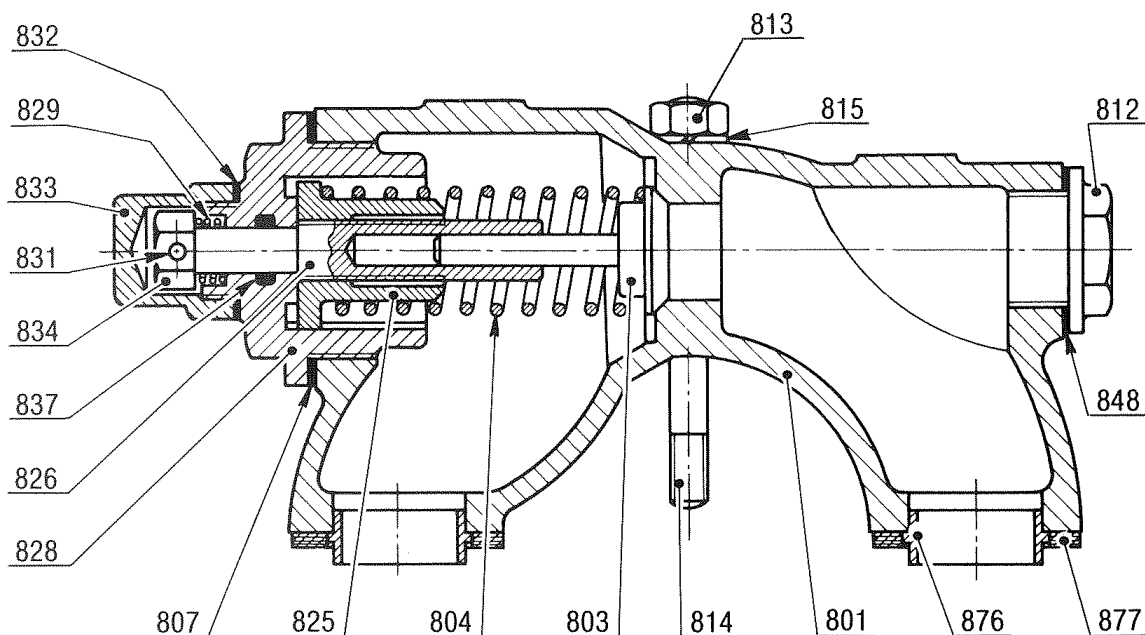

Temperature of pumped product

AF TM H pumps are suitable for pumping domestic fuel and heavy fuel heated up to 0° C and 180° C with the following recommendations :

- before transferring heavy fuel, preheat the whole installation
- rinsing the installation with domestic fuel immediately after each operation with heavy fuel.

For others conditions of use, report to our Technical Department.

Pressure setting

To set bypass, remove cap **833**. To increase pressure setting, turn adjusting nut **834** clockwise. To reduce pressure setting, turn the nut counterclockwise.

When the setting is finished, dont forget to replace cap **833**.

With the bypass spring, it is possible to set the pressure between 1,7 and 6,5 bar (valve closed).

Delivery ajustement

When the pump does not deliver the proper flow rate, the trouble may come from bypass spring not being adjusted at the correct pressure setting.

After making sure that the rotation speed is correct, tighten adjusting nut **834**.

Should the spring be completely tightened or the motor operation disturbed, without getting the delivery wanted, it would mean that the unit should operate at a higher pressure than the pressure for which it has been designed. Please report to our Technical Department.

Standard bypass use

Standard bypass use should not be operated too frequently (even less permanently) since it would result in useless power consumption and material fatigue detrimental to equipment.

DISASSEMBLY / REASSEMBLY

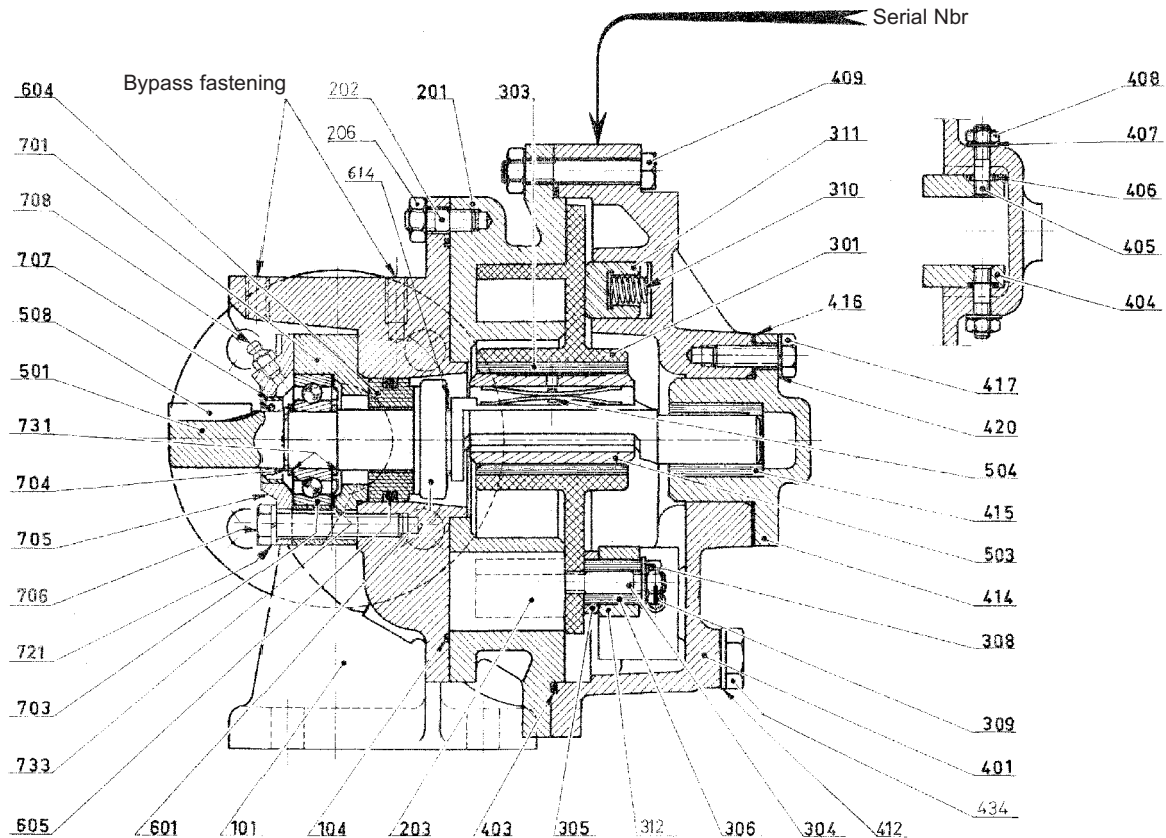

Disassembly

Opening the pump :

- Remove end-plate bolts **409**.
- Remove end-plate **401** by prying it loose. Using a screwdriver as a lever, back piston **301** and shaft **501** away from pump.

To remove piston :

- Free the piston **301** by sliding it along the shaft **501**.

To remove shaft seal, bearing and shaft :

- Refer to § SHAFT SEAL.

Reassembly

Reassembly is undertaken in the reverse order of dismantling. Before assembling, check that spring **504** of piston bearing **503** and piston backsprings **310** has not weakened.

To reassemble shaft seal, bearing and shaft :

- Refer to § SHAFT SEAL.

To reassemble piston and to close the pump :

- After remounting in place the seal end-plate **403**, engage the piston **301** on the shaft **501**.
- Insert the piston **301** in the cylinder **201**, by making bend the spring **504** of piston bearing **503** and push tight to the end.
- The end-plate **401** has to come effortlessly to apply on the cylinder **201**.
- Screw the end-plate bolts **409**.

Nota - When you reassemble the pump, make sure seals are in good condition.

SHAFT SEAL

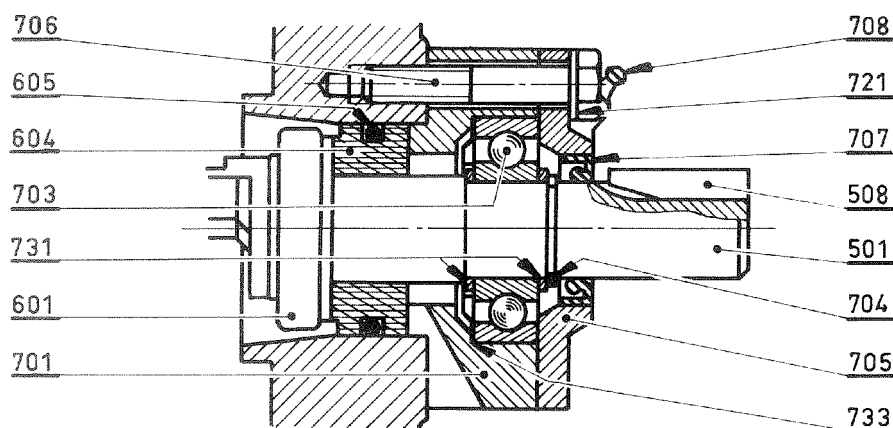

Operation

MONOSIR block **601** is held in shaft by its rubber face. Stationary seal **604** is held in pump body by ring **605**. Tight sealing depends on :

- ring **605** and rubber face of **601**.
- sealing faces being perfectly flat and mirror smooth, of stationary seal **604** and **601**.

Disassembly

After opened the pump :

- remove screws **706** and washers **721**, cap **705**, outer seal **707** and drive out retainer **701** with shaft, bearing and all parts constituting the shaft seal.
- remove snap ring **704**, drive out shaft from bearing by tapping on shaft end and remove the set **701-731-733-703**.
- remove the set **604-605**, then all MONOSIR block **601**.

MONOSIR block **601** must not be dissociated.



Reassembly

- Check rings **707**, **605** and rubber faces of block **601**.
- Check that sealing faces of **604** and block **601** are flat and mirror smooth.
- Replace all parts on shaft in the reverse order and install snap ring **704**.
- Replace on the pump shaft, ball bearing and shaft seal making sure one of the drain vents is turned downwards.
- Then, install seal **707** taking care not to damage seal **707** on key-groove, bearing cap **705** (bearing grease nipple turned upwards), screws **706** and washers **721**.

STORAGE

If necessary, refer to § DISASSEMBLY / REASSEMBLY for pump disassembly.

Short duration (≤ 1 month)

 WARNING	IF PUMPING HAZARDOUS OR TOXIC FLUIDS, THE SYSTEM MUST BE FLUSHED PRIOR TO PERFORMING ANY SERVICE OPERATION.
	
Toxic or hazardous fluids can cause serious injury.	

MOUVEX pumps and motor-driven pumps are well lubricated when delivered to protect the internal parts during brief storage in a building where :

- the temperature remains between 10°C and 50°C.
- the relative humidity does not exceed 60%.
- exposure to vibration is limited.
- pump is stored in an area sheltered from bad weather and sun.

Long duration (> 1 month)

The recommendations from the manufacturer should be followed if the pump is stored with its gear motor.

Pump ports should be filled with a non-corrosive liquid that it compatible with the pump components in order to prevent corrosion.

Unpainted external surfaces of the pump (e.g. shafts, couplings, etc.) should be covered in some form of anti-corrosion protection.

The bearing should be well greased. If the pump is to be stored for more than the life of the grease, this one should be replaced in time to prevent an excessive degradation of its qualities.

The best storage conditions are inside a building that meets the conditions set out above.

If inside storage is not possible, the materials should be covered to prevent direct exposure to sun and bad weather. This protection should also prevent condensation.

The pump should be turned a few revolutions manually every two months.

Restarting

Follow the standard start-up procedure for the pump/ motor-driven pump, as well as the instructions below.

Turn the pump by hand to make sure the parts move freely.

Replace the grease used to lubricate the bearing.

If the pump has a safety bypass, remove it and inspect the parts and make sure they move freely (see § BYPASS for removal instructions).

SCRAPPING

The pump must be scrapped in compliance with the regulations in force.

During this operation, particular care must be paid to the drainage stages of the pump.