



# M-200

## High flow, adjustable flow switch with right angle Flow



## Operating Instructions and Quick Start Guide

**Corporate Headquarters**  
1060 S Rogers Circle  
Boca Raton, FL 33487  
P: (561) 995-0595 F: (561) 995-0622

**West Coast Headquarters**  
2329 Zanker Road  
San Jose, CA 95131  
P: (408) 970-3419 F: (408) 970-3426

**South East Asia Headquarters**  
35, Marsiling Industrial Estate Road 3,  
02-06, Singapore 739257  
P: (65) 6482-3533 F: (65) 6484-4231

**India Headquarters**  
3rd Floor Hanumathra Arcade, # 17&18,  
60 Feet Road, Pattegarapalya Main Road,  
Vijayanagar North, Bangalore 560079  
P: (91) 80 2350-4361 F:(91) 802301 1205

# Table of Contents

<b>Introduction</b>	<b>03</b>
<b>Operation</b>	<b>03</b>
<b>Storage and Handling</b>	<b>03</b>
<b>Installation Instruction</b>	<b>03</b>
<b>Construction</b>	<b>03</b>
<b>Specification</b>	<b>04</b>
<b>Certification</b>	<b>05</b>
<b>Dimensional drawings</b>	<b>05</b>
<b>Flow Setting</b>	<b>07</b>
<b>Ordering Information</b>	<b>08</b>
<b>Warranty</b>	<b>08</b>

## Introduction

The M-200 Series flow switches are engineered and field tested for sensing increasing and decreasing flow rates of gases or liquids. Pressure variation effects are minimal. This series features such versatility, economy, and accuracy that they can be used in virtually any application requiring fool-proof inexpensive flow detection.

## Operation

The flow switch is activated by flow forcing a piston kept in place by a spring to travel past a reed switch. This provides a positive signal after a certain amount of travel. Set point adjustment is controlled by adjusting the positioning of the reed switch.

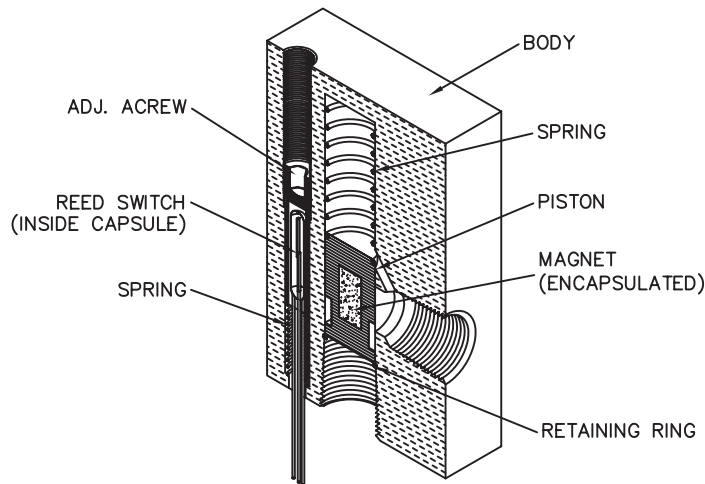

Illustrated is the M-200 Model with 3/8" ports.

## Storage and Handling

### Storage conditions

Store the product under packed condition in an anti-static bag. The storage place shall be free from moisture, mechanical shock and vibration. The ambient temperature shall be between 0°C and 60°C and the humidity between 5% and 80% R.H. without condensation.

### Unpacking and Product Inspection

On delivery, check the product for damage. Confirm that the model code on the label matches the specification in the purchase order.

## Installation Instructions

This product can be mounted in any orientation. Adequate filtration and sealing procedures should be used when mounting in flow lines.

### Operating Environment

Choose a location with an ambient temperature of 10-35°C and relative humidity value <80% RH without exposure to direct sunlight. Avoid environments with high electromagnetic noise or vibration. Make sure that the module is protected from corrosive liquid or water splashes. For best performance avoid corrosive environments since they may degrade the performance of the electronics after a period of time. Easy access for maintenance and inspection is always recommended.

## Construction

The M-200 Series comprises a Body, piston, and Retaining rings. Selecting a flow switch begins with selecting the body; this series is available in 316 Stainless Steel. The M-200 series contains one moving part (i.e. the piston) and two retaining rings that are in the fluid path. Construction of the piston is important from a design perspective. We manufacture three types of pistons (It is critical to select the correct piston for your application): 316 Stainless Steel, PTFE encapsulated, and Special All-Metal Piston.

1. The standard piston is a 316 Stainless Steel piston with epoxy to hold the magnet in place. This piston is recommended for non-aggressive fluids and inert gases. Stainless Steel retaining rings are typically used with this piston type.

2. The second piston that is available is a PTFE Encapsulated one. The piston is a magnet that has PTFE moulded around it and then machined to the appropriate configuration. These pistons are primarily used in PTFE flow switches and also in other flow switch bodies ( typically 316SS and Acrylic bodies ) where customer prefer a piston that does not have epoxy in the fluid path; as well as a piston that is impervious to aggressive fluids and gases. This piston is highly recommended for medical applications. Hysteresis on these pistons does tend to be slightly higher (10 to 15% ) than metal piston due to frictional effects, weight, and surface adhesion considerations. Prior to selecting this piston, fluid temperatures, and fluid compatibility with PTFE must be taken into account because certain aggressive chemicals at specific temperatures tend to swell PTFE causing the piston to change shape resulting in failure of the product. Stainless or PTFE retaining rings can be used with this piston.
3. The third piston that is available is a Special All-Metal piston with no epoxy ( only available in 316SS ). This piston is fabricated in a proprietary process with only one weld seam ( leak tested ) which presents an all 316SS surface to the fluid path. This piston is recommended for those applications where the piston could experience a lot of cycling wear. This piston has been tested to 250,000 cycles at 125 psi. Stainless Steel retaining rings are recommended for this piston type for low pressure applications and an orifice disc ( See Universal Mounting Diagram ) is recommended for high pressure ( 125 psi ) applications.

### SPST vs SPDT

The standard unit is provided with a **SPST N.O.** (N.O = Normally open at rest) dry reed switch. Increasing flow past point will close (activate) the switch. Decrease flow will open (de-activate) the switch).

**SPST NC.** (N.C = Normally close at rest) models are closed at rest. Increasing flow pass set point opens the switch and decreasing flow to set point will close the switch( Typically used to detect loss of flow condition in overall systems)

**SPDT** (Single Pole Double Throw) switches have both N.O. & N.C. configurations by using a common pole along with two additional poles to achieve this dual capability.

### Conversion from N.O. (Normally Open) to N.C. (Normally closed)

1. Loosen allen set screws (4 - 40) on face of body. These are the set screws holding the reed switch in place.
2. Move the reed switch downwards until it shows a closed contact on the multi-meter.
3. Tighten (4 - 40) allen set screws on face of the body.
4. Cycle until on and off by turning upside down to simulate flow. This may necessitate some refinement of the exact location of the reed switch as determined in step 2.

### Precautions during installation

1. Avoid any foreign particles during installation.
2. Large metallic and/or magnetic fields may affect the principle of operation of these units. if disturbance is detected, magnetic shielding may be necessary to ensure correct operation of the flow switch.
3. During installation of explosion proof versions carefully screw in the conduit connector for the electrical leads piping so as to avoid damaging the reed switch leads or reed switch capsule which may lead to shorting the switch installation. 6 (Six threads) have been provided for installation.
4. Electrical ratings etc. have been discussed later in this bulletin. it is advisable to keep within those ratings as excessive power will FRY the switch.

### Electrical Protection/Ratings

The electrical Reed Switch is rated for several million cycles and should rarely require replacement. Most switch failures are the result of overloading. **DO NOT EXCEED RATED CAPACITY**, as this will cook the REED SWITCH, Catalogue ratings are based upon D.C. resistive loads, however A.C. loads are also commonly switched.

Inductive load switching- Unless appropriate contact protection is provided with either a diode or R.C. network, inductive load switching will cause the contacts to stick.

Capacitive load switching - The static capacitance in cables may cause permanent or intermitter contact sticking. Contacts may be protected by a series surge protector of 0.5 to 5 mA<sub>H</sub>, depending on the load. in some instances, a 10-500 ohm resistor can replace the surge suppressor.

### Cleaning

Cleaning the flow switch is easily accomplished without removing from the line. By unscrewing the clean out plug, the magnetic piston may be removed and the flow passage flushed or cleaned. Care should be taken to thoroughly clean the piston before replacing ( replace the piston as shown in see page 3 figure 2. if the piston is replaced incorrectly, incorrect operation will result).

1. A magnet may be used to remove the magnetic piston.
2. PTFE end plugs (on PTFE models) should not be over tightened.

## Reed Switch Replacement

For reed Switch replacement

1. Loosen allen set screws (4-40) on face of body.
2. Remove and replace reed switch if needed.
3. **Normally Open**

Move switch downward until switch closes then move upward until switch opens. Very gently retighten allen screws.

### Normally Closed

Move switch downward until it closes then move upward very slightly maintaining a closed contact. Very gently retighten allen screws.

4. If possible cycle unit on and off to test. if unit is not installed, turning upside down will simulate the flow.

## Specifications

### Construction Materials

Housing	Acrylic	Aluminium	Brass	316SS	PTFE
Piston	316SS				PTFE
Orifice Plate or disc	316SS				PTFE
Spring	316SS				N/A
Retaining Ring	Stainless Steel (PH 15-7 MO, AMS 5520, AISI-632) (Passivated)				PTFE
<b>Pressure and Temperature Specifications</b>					
Maximum Operating (psig)	200	1,000	1,500	3,000	80
Burst (psig)	400	3,000	3,000	5,000	160
Maximum Operating Temperature	77°C (170°F)	149°C (300°F)	149 C (300°F)	149 C (300°F)	104 C (220°F)
Flow calibration	( Higher accuracy units available )				
Set point Accuracy	10% maximum				
Set point Differential( Deadband )	15%				
Repeatability	± 2 maximum				
Reed Switch Data (Electrical Ratings) Reed Switch	10 Watts SPST or 3 Watts SPDT (Hermetically Sealed) UL Recognized. File E47258 Operating temperature -40°C to 125°C				
Switching Voltage	200 VDC ( 170 VDC for SPDT )				
Breakdown Voltage	250 VDC ( 200 VDC for SPDT )				
DC Resistive	10 VA (3 VA for SPDT )				
AC Resistive	10 Watts (3 Watts for SPDT )				
Switching Current	0.5 A ( 0.25 A for SPDT ) 1.2 A ( 0.5 A for SPDT )				
Lead Wires	No 24 to 18 AWG. 18" length, Polymeric UL Recognized ( Belden cable or special shielded cable is available )				
Lead Wires Color	SPST: 2 blue wires SPDT: Green - Common, Yellow - Normally Closed, Orange - Normally Open				

## CONTACT ARRANGEMENT

### Electrical Color Coding

SPST	2 Blue Wires
SPDT	Orange - Normally Open Yellow - Normally Closed Green - Common

## Certifications

### UL Recognised

UL Recognised for Non Hazardous location – UL 138467

### CE Compliance

Malema flow switches meets CE compliance under LVD 2014/35/EU. RoHS and REACH can be obtained from Malema on request.

## Dimensional and Cut-Away drawings

Illustrated is the M-200 model with 3/8" ports

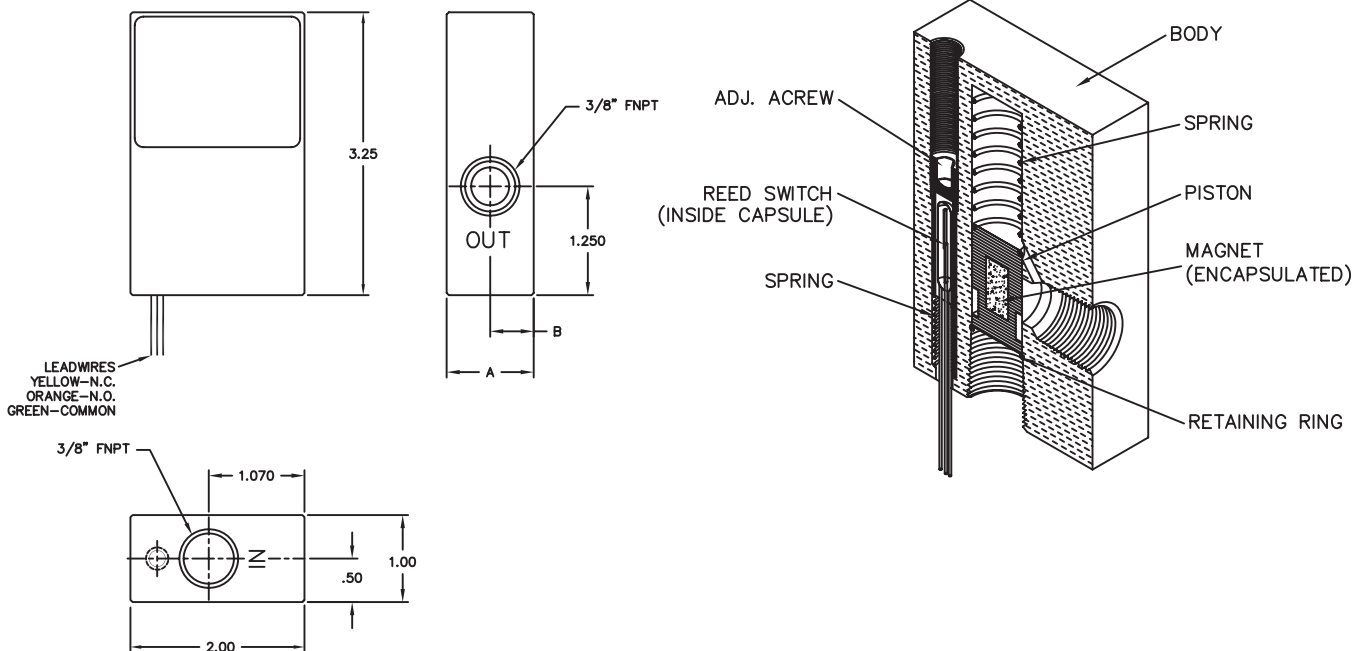

Housing	A	B
Acrylic	1.25"	0.625"
Aluminum	1"	0.500"
Brass	1"	0.500"
316SS	1"	0.500"
PTFE	1.25"	0.625"

# Dimensional and Cut-Away drawings

Illustrated is the M-200 model with 3/4" ports

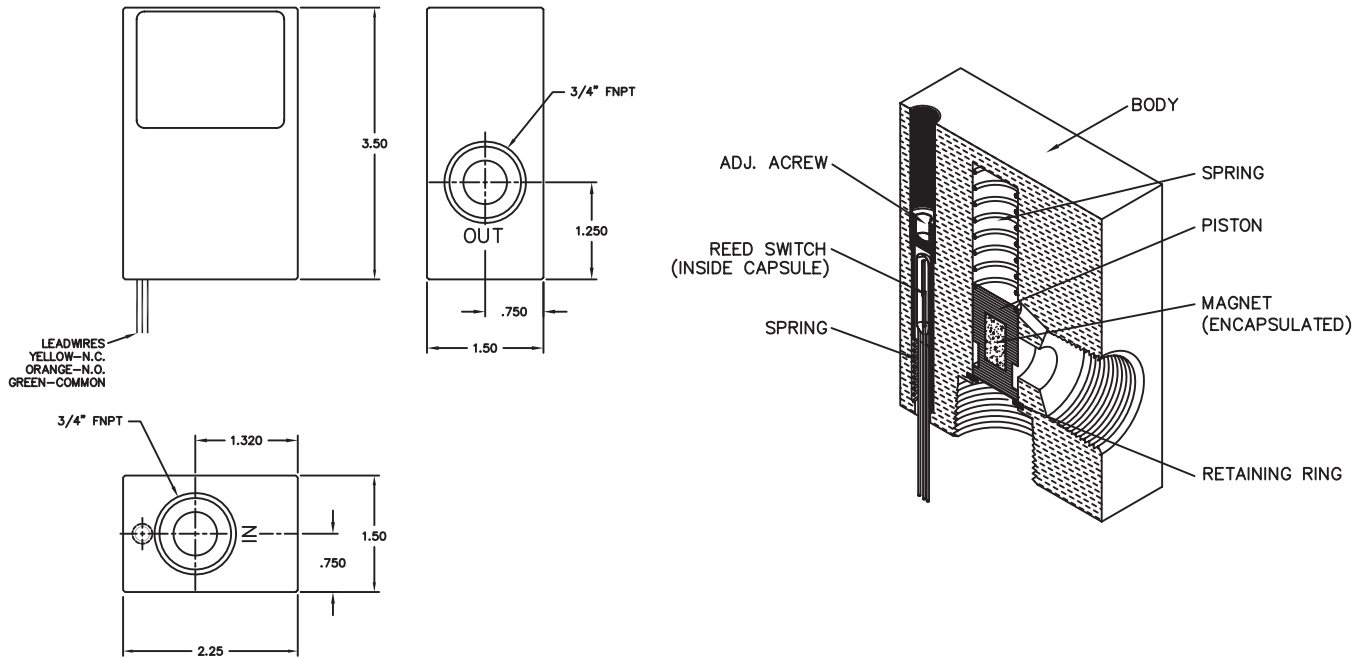

\* Note: The M-200 Model with 3/4" ports is only available in Brass, PTFE and 316SS

Illustrated is the M-200 Model with SAE8 ports.

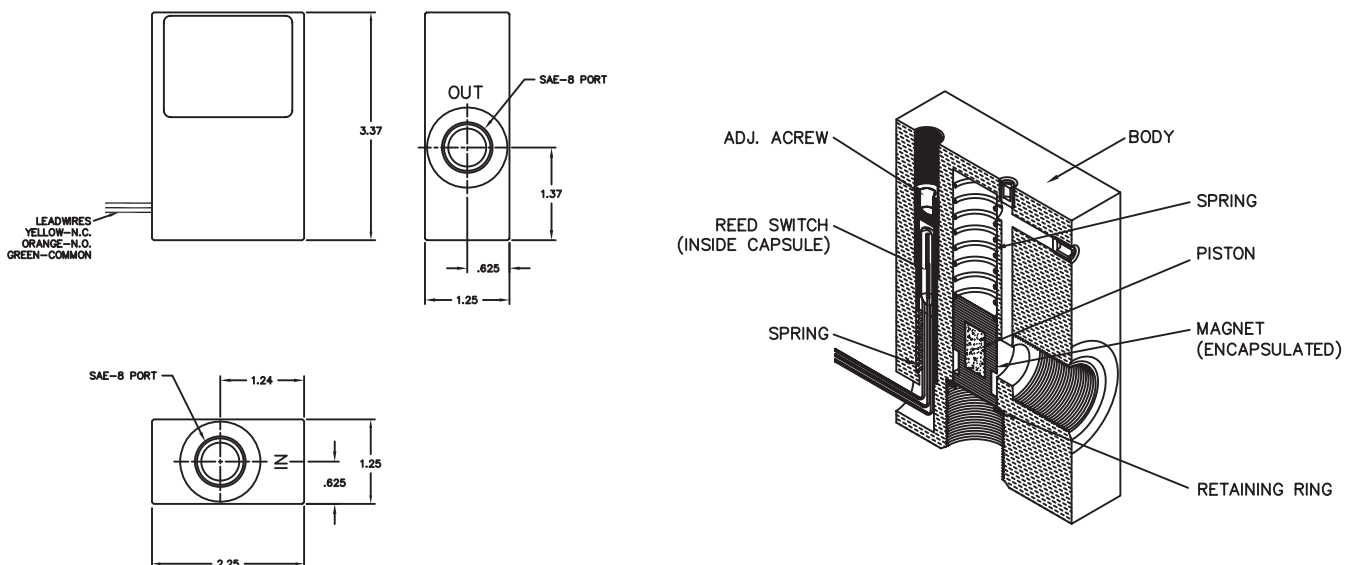

\* Note: The M-200 Model with SAE8 ports is only available in Brass and 316 Stainless Steel

# FLOW SETTING

The flow setting is adjustable. This is achieved by means of the setscrew. By turning the set-screw clockwise, the flow setting would be decreased, and by turning it counterclockwise, the flow setting increases.

## Ordering Information

Standard Part Numbering						
M	-	Model	-	Material	Port	Switch
M	-	200	-	S	1	1
		200		A - Aluminum B - Brass P - Acrylic S - 316 Stainless T - PTFE	3 - 3/8" 4 - 1/2" 6 - 3/4"*	1 - SPST N.O. 3 - SPDT

\* The M-200 with 3/4" ports is ONLY available in the Brass, PTFE or 316SS body material.

The M-200 in Brass or 316SS is also available with SAE8 ports.

**Note:** The flow switch performance will be affected in the vicinity of Magnets, Electromagnets, and Ferrous metals. Hence adequate protection should be provided while installing in close proximity to such interferences or relocate the flow switch away from them appropriately.

## Warranty

Malema Sensors warrants to the buyer that its products are free from defects in materials and workmanship at the time of shipment and during the WARRANTY PERIOD. Malema Sensors obligation under this warranty is limited to the replacement of the product(s) by same product(s) manufactured by Malema Sensors or repair of the product(s) at the Malema Sensors facility. Malema Sensors products are sold with the understanding that the buyer has determined the applicability of the product(s) to its intended use. It is the responsibility of the buyer to verify acceptability of performance to the actual conditions of use. Performance may vary depending upon these actual conditions.

### Warranty Period

This warranty is in effect for twelve (12) months from the date of shipment from Malema Sensors place of business.

### Warranty Claim

If Malema Sensors products are found to be defective in materials or workmanship within twelve (12) months of the date of shipment, they will be repaired or replaced with same product at the discretion of Malema Sensors at its place of business at no charge to the buyer.

### Return

To return the products, please obtain an RMA number for the product by contacting Malema Sensors (Corporate Office), Boca Raton at (800) 637-6418 or (561)995-0595.

All returns of equipment must go to the following address:

Malema Sensors,  
1060 S Rogers Circle  
Boca Raton, FL 33487, USA

**NOTE: Specifications are subject to change without notice.**

© 2018 Malema Engineering Corporation. All rights reserved.

Malema Sensors® is a registered trademark of Malema Engineering Corporation. Malema, the Malema logo, and Malema Engineering Corporation are trademarks of Malema Engineering Corporation. All other trademarks are property of their respective owners.

Malema supplies this publication for informational purposes only. While every effort has been made to ensure accuracy, this publication is not intended to make performance claims or process recommendations. Malema does not warrant, guarantee, or assume any legal liability for the accuracy, completeness, timeliness, reliability, or usefulness of any information, product, or process described herein. We reserve the right to modify or improve the designs or specifications of our products at any time without notice. For actual product information and recommendations, please contact your local Malema representative.