



M-2111 Series Ultrasonic Flow Meter

User Manual

Copyright

All rights reserved, especially with respect to reproduction, distribution and translation. This user manual or any part thereof must not be reproduced, saved, processed, duplicated or distributed without the written consent of PSG.
© Copyright 2026 Malema®. All rights reserved.

Subject to Technical Changes

Owing to our policy of continuous product development, the illustrations and technical data contained in this document may differ slightly from the current version of the device.

Legal Manufacturer

Malema Engineering Corp. or Malema Sensors
1060 S Rogers Circle, Boca Raton, FL 33487

Telephone: +1 408-970-3419 or 1-800-637-6418

Certifications/Compliances

CE Compliance via the following testing:

1. EN61000-4-2: Electrostatic Discharge
2. EN61000-4-3: Radiated Immunity (and Radiated Emissions)
3. EN61000-4-4: Electrical Fast Transients
4. EN61000-4-5: Surge - Power Line
5. EN61000-4-6: Conducted Immunity

Support Email Address

Please contact the Malema Customer Support Team at the email addresses below,

General Support:

Malema.GeneralSupport@psgdover.com

Customer Support:

Malema.CustomerSupport@psgdover.com

Order Support:

Malema.OrderSupport@psgdover.com

Quote Support:

Malema.QuoteSupport@psgdover.com

Technical Support:

Malema.TechnicalSupport@psgdover.com

Index

1.00 Introduction	5
1.01 Overview	5
1.02 Storage conditions	5
1.03 Unpacking and Product Inspection	5
2.00 Installation	6
2.01 Selecting location	6
2.02 Mounting of Flow Detector	6
2.03 Start Up	6
2.04 Connection	7
2.05 Front panel button menu	8
3.00 Specification	9
3.01 Performance Specification	9
3.02 Flow Detector Specification	9
3.03 Signal Converter Specification	10
3.04 Connection Details	11
4.00 Dimension Drawing	13
4.01 Flow Detectors	13
4.02 Converter without display	14
4.03 Converter with display	14
5.00 Ordering Information	15
6.00 Maintenance	15
7.00 Warranty	16
8.00 Service Contacts	16
9.00 Service and Repair	16

1.00 Introduction

1.01 Overview

The Malema Sensors® M-2111 Flow Meter is the world's most advanced transit-time ultrasonic flow measurement system. It is also one of the most feature-rich and flexible flow measuring device in the market, finding applications from sewage plants to semiconductor fab clean rooms, and everywhere in between.

Malema ultrasonic flow meters are designed to measure the fluid velocity of liquid within closed conduit (pipe). The transducers are a non-contacting type. Two transducers spaced at a specific distance from each other function as both ultrasonic transmitters and receivers. The flow meter operates by alternately transmitting and receiving a frequency-modulated, burst of sound energy between the two transducers and measuring the time interval that it takes for the sound to travel between the two transducers. The difference in the time interval measured is directly related to the velocity of the liquid in the pipe that is used to derive the flow rate.

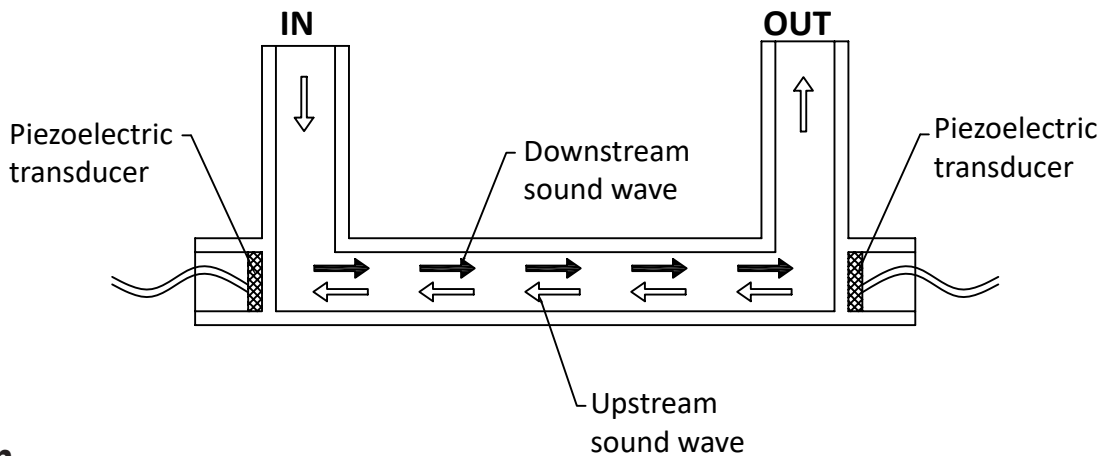

Certification

CE Compliant

M-2111 Series complies to the following standards:

Emission: FCC Part 18 & EN 55011:1998 w/ A1:1998 & A2:2002 (Group 1)

Immunity: EN 61000-6-2:2005

EN61000-4-2 Electrostatic Discharge (4kV contact, 8kV air)

EN61000-4-3 Radiated Immunity (80 MHz - 2.7 GHz)

EN61000-4-4 Electrical Fast Transients (2kV DC port, 1kV signal ports)

EN61000-4-6 Conducted Immunity (10Vrms)

1.02 Storage Conditions

Store the product under packed conditions in an anti-static bag. The storage place should be free from moisture, mechanical shock and vibration. The ambient temperature should be between 10°C and 35°C and the humidity between 5% and 80% R.H. without condensation.

1.03 Unpacking and Product Inspection

Upon delivery, inspect the product for damage. Confirm that the model code on the label matches the specification in the purchase order.

Confirm that you have received the following items:

- Transducer
- Converter
- A physical copy of this operating manual

2.00 Installation

2.01 Selecting Location

The following must be considered when selecting a location to install the Flow Detector:

1. Ambient temperature: 10 to 35°C (50 to 95°F) protected from direct sunshine.
2. Free from electromagnetic interference. Keep away from such heavy inductive devices as motors, pumps, power-relays, and solenoid valves.
3. The location must be protected from water splashes or corrosive gases.
4. The location should be of easy access for maintenance.

2.02 Mounting of Flow Detector

Consider the following when selecting and installing Flow Detector for accurate measurement.

1. Flow Detector can be installed at any angle – vertical, horizontal or inclined. The best angle, however, is vertical with upward flow direction for U-shaped sensor and 45 degrees with the inlet and outlet tube sections facing up in 45 degrees for Z-shaped sensor. With this angle, air bubbles are less likely to be trapped in the flow detector, and furthermore fluid can be easily drained when maintenance work is needed.
In the case that the flow detector is to be mounted in a horizontal pipe run, raise the downstream side slightly to prevent bubble stagnation. Please make sure that there is no deposit in the detector during operation. If there is a possibility of deposits occurring, periodically flush with a clean liquid such as water.
2. To install on a pipe that has an open end, mounting should be at the lower position of the pipeline.
3. The arrow on side plate of Flow Detector shows flow direction. Make sure the arrow matches the direction of flow.
4. Flow Detector should be mounted where pressure in the pipe is above atmospheric.
5. A flow control valve is recommended downstream of the Flow Detector to prevent formation of bubbles in the liquid. An upstream valve may form bubbles, thus attenuating the ultrasound signal and resulting in measurement noise.
6. A bypass pipe (including bypass valve and shutoff valve) is recommended for easy zero adjustment and maintenance.
7. Use two threaded holes for the mounting of Flow Detector on the bottom. Take great care to avoid mechanical stress on the inlet and outlet pipes.
8. Please refer to section [4.00 Dimension Drawing](#) for the connection of the inlet and outlet pipes.

Mounting of Converter:

The converter is of DIN rail mounting type.

2.03 Start Up

The M-2111 Series flow meter system requires a full pipe of liquid medium at rest before a successful startup can be completed.

Preliminary Checks:

Make sure that the Detector and Converter serial numbers match.

1. Make all the necessary connections as per the connection details on section [3.04 Connection Details](#).
2. Ensure that the power supply rating is 24 V DC \pm 10%, 300mA.
3. Confirm that the flow direction arrow on the Detector points in the same direction as the physical flow direction.

2.00 Installation

2.03 Start Up

Start up Process:

1. Turn on the power to the converter – The instrument will go through initialization process and start measuring flow.
2. Please allow the instrument to warm up for about 10 minutes.
3. Verify that the flow tube is full of stationary liquid without bubbles.
4. ZERO RESET through either the 'remote zero in' terminal or via 'Set Zero' menu accessible by the front panel switches.
5. The flow meter is now ready for making valid measurements.

NOTE: To read valid flow rates, 'ZERO calibration' needs to be done whenever the measurement fluid properties change or the installation set-up is different than the one used for the previous 'ZERO Calibration'.

2.04 Connection

Electrical Wiring

4-20 mA active current Output

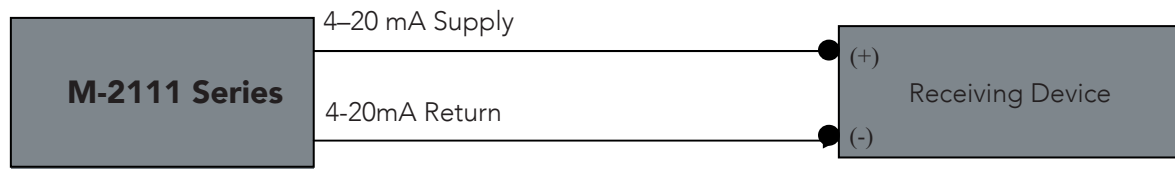

4-20 mA passive current Output

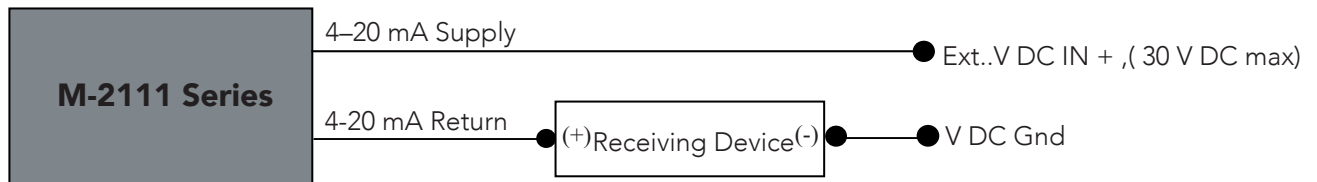

** Digital O/p (Status 1, Status 2, Pulse)

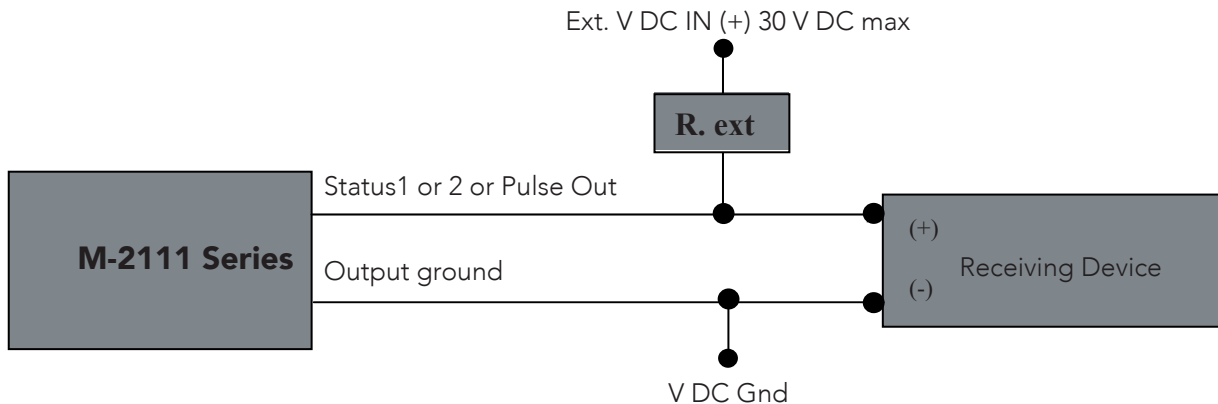

R. Ext is an external resistor that may be needed for some installations.

Choose R. ext so that the maximum current through the terminal does not exceed 200 mA.

R. Ext can be calculated as follows:

$$R. \text{ Ext (k}\Omega\text{)} = \text{Ext. V DC In} / \text{Max. Current (mA)}$$

2.00 Installation

2.04 Connection

Electrical Wiring

***Remote Zero reset Input

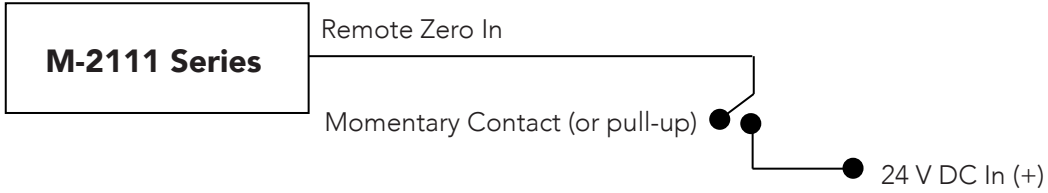

2.05 Front Panel Button Menu

View Menu

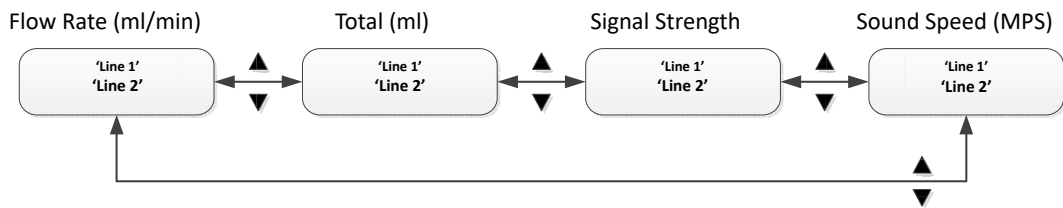

Program Menu

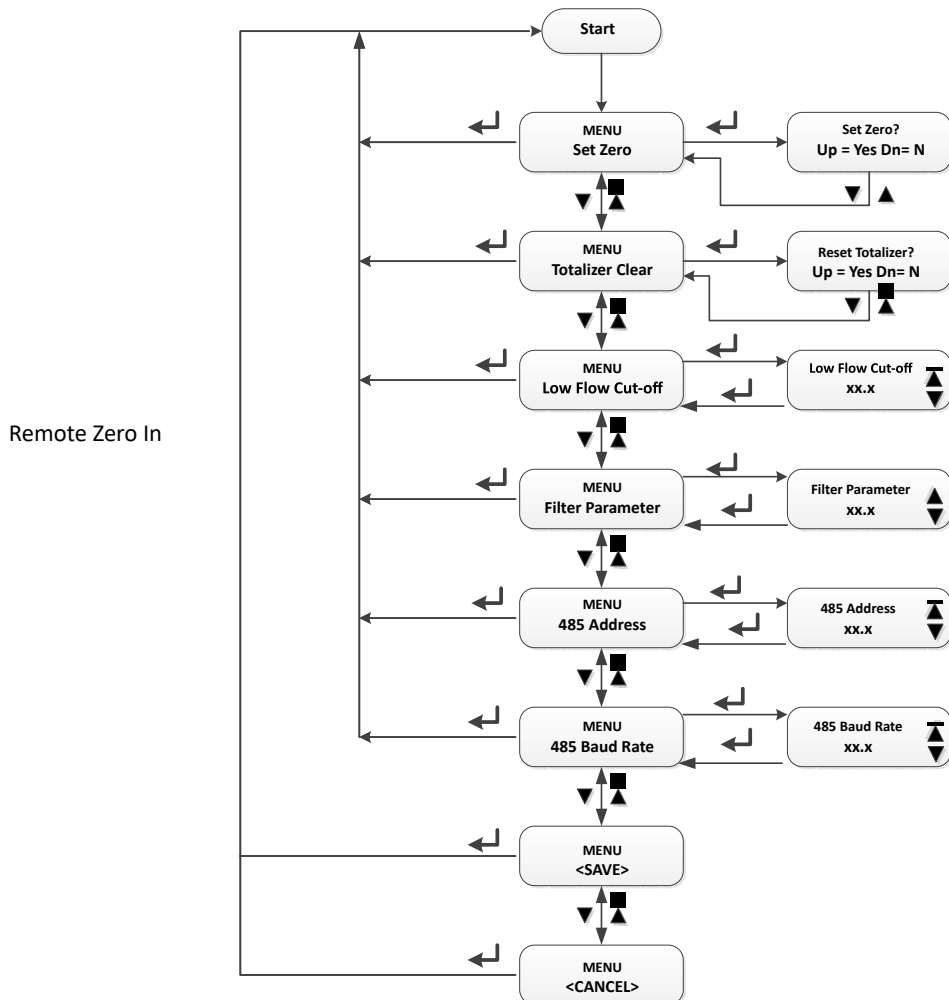

3.00 Specification

3.01 Performance Specification

Range Code	Flow Range (l/min)	Connection Tube Size
	Max. Range	
04	0 - 3.0	1/4" or 3/8"
06	0 - 8.0	3/8"
10	0 - 20.0	1/2"
15	0 - 50.0	3/4"
20	0 - 80.0	1"

Table 1: Flow Range and Connecting Tube Size

Range Code	Accuracy	Repeatability
04	±5 ml/min below 500 ml/min* ±1% of reading above 500 ml/min	±0.5 ml/min below 100 ml/min ±0.5% of reading above 100 ml/min
06	±12 ml/min below 1200 ml/min ±1% of reading above 1200 ml/min	±3 ml/min below 600 ml/min ±0.5% of reading above 600 ml/min
10	±0.047 l/min below 4.7 l/min ±1% of reading above 4.7 l/min	±0.024 l/min below 4.7 l/min ±0.5% of reading above 4.7 l/min
15	±0.106 l/min below 10.6 l/min ±1% of reading above 10.6 l/min	±0.053 l/min below 10.6 l/min ±0.5% of reading above 10.6 l/min
20	±0.188 l/min below 18.8 l/min ±1% of reading above 18.8 l/min	±0.094 l/min below 18.8 l/min ±0.5% of reading above 18.8 l/min

*Flow meter specified with 100 ml/min full scale or less can be provided with ±2 ml/min accuracy. Please consult the factory for special requirements.

Note: Accuracy statement is based on a room temperature DIW calibration.

Table 2: Accuracy and Repeatability

Part Name		Material
Wetted Part	Body	PFA
	Tube	PFA
Housing (Size 10 / 15 / 20)		PTFE
End Cap (Size 04 / 06)		PP
Cable Fitting		PP
Cable Jacket		PU

Table 3: Materials of Flow Detector

3.02 Flow Detector Specification

Measurable Fluid	Liquids
Fluid Temperature	10°C to 60°C*
Fluid Pressure	0 to 70 psig
Process Connection	PFA Tube End (Refer to Table 1)
Enclosure Classification	IP65
Flow Range	Refer to Table 1

*Consult Malema for higher temperature applications.

3.00 Specification

3.03 Signal Converter Specification

Input Power	24 V DC \pm 10%
Power Consumption	3.3 W Max. Approx @ 140 mA (Continuous) Max. 200 mA
Ambient Temperature / Humidity	0°C – 50°C / 30% – 80% RH
Installation	DIN Rail Mounting
Enclosure Class	IP 20 (Indoor use)
Materials	Polycarbonate
Weight	Model B01 - 530 grams / Model D01 - 225 grams
EMC	To be tested soon
Sensor Cable	Shielded twisted pair
Electrical Connection	Pluggable screw terminals, accepts 28 to 16 AWG wire
Analog Output	Current O/P: Active: 4 to 20 mA (Max. Load < 900 ohms) Passive: 4 to 20 mA (Max. Load < 1200 ohms @ 30 V max.) Voltage O/P: 0 to 10 V DC (min. load > 10K ohms)
Pulse Output	Open Collector (sinking)/Max. 30 V DC, 200 mA max. Pulse (Hz) - 10 kHz max., Configurable Pulse (Volume) - Pulse weight from 0.1 ml to 1000000 Gallons, Configurable
Digital Output	Open Collector / Max. 30 V DC, 200 mA max. Two digital outputs configurable for Low flow rate/High flow rate/Totalizer greater than/Totalizer less than/Signal strength less/Positive totalizer pulse LED Alarm indication
Digital Input	Zeroing - Momentarily pull-up to 24 V DC for activation Totalizer Reset - Contact closure or V DC pull-up (5 V DC max)
Low Flow Cut-off	Configurable
Linearization	Max. 14 points (Configurable)
Display (Optional)	LCD: 2 line 16 digits alpha numeric (with backlight) with LED alarm indication
Digital Communication	RS-485 and RS-232

Table 4: Model: USC-B01 & USC-D01

3.00 Specification

3.04 Connection Details

Terminal Assignment	Description
24VDC In (+)	Power I/P (+)
Power Ground	Power (Gnd)*
IN (Red)	Sensor IN/Upstream (a)
IN (Black)	Sensor IN/Upstream (b)
Shield Ground	Sensor Shield
OUT (Red)	Sensor OUT/Downstream (a)
OUT (Black)	Sensor OUT/Downstream (b)
RS-485B	Digital comm, Data (-)
RS-485A	Digital comm, Data (+)
Ground	Digital comm, Data (Gnd)
Control 0-10 V In	Set point input (+), ONLY for closed loop control application
Signal Ground	Set point I/P (Gnd), ONLY for closed loop control application
4-20 mA Supply	Current O/P (+) , Factory set to ACTIVE O/P (See Note 1)
4-20 mA Return	Current O/P (-) , Factory set to ACTIVE O/P (See Note 1)
0-10 V Analog Out A	Voltage O/P (+)
0-10 V Analog Out B	No connection
Signal Ground	Voltage O/P (Gnd)
Status 1 Out	Digital O/P (+), assignable, open collector**
Status 2 Out	Digital O/P (+), assignable, open collector**
Pulse Out (frequency)	Digital O/P - Frequency (Hz) O/P (+), open collector**
Output Ground	Digital O/P Gnd
Remote Zero In	Set zero***
Batch Total Reset In	Total reset***
Input Ground	Digital I/P (Gnd) ***

Note: Please consult Malema for passive current output requirement.

3.00 Specification

Connection Details (Converter label view)

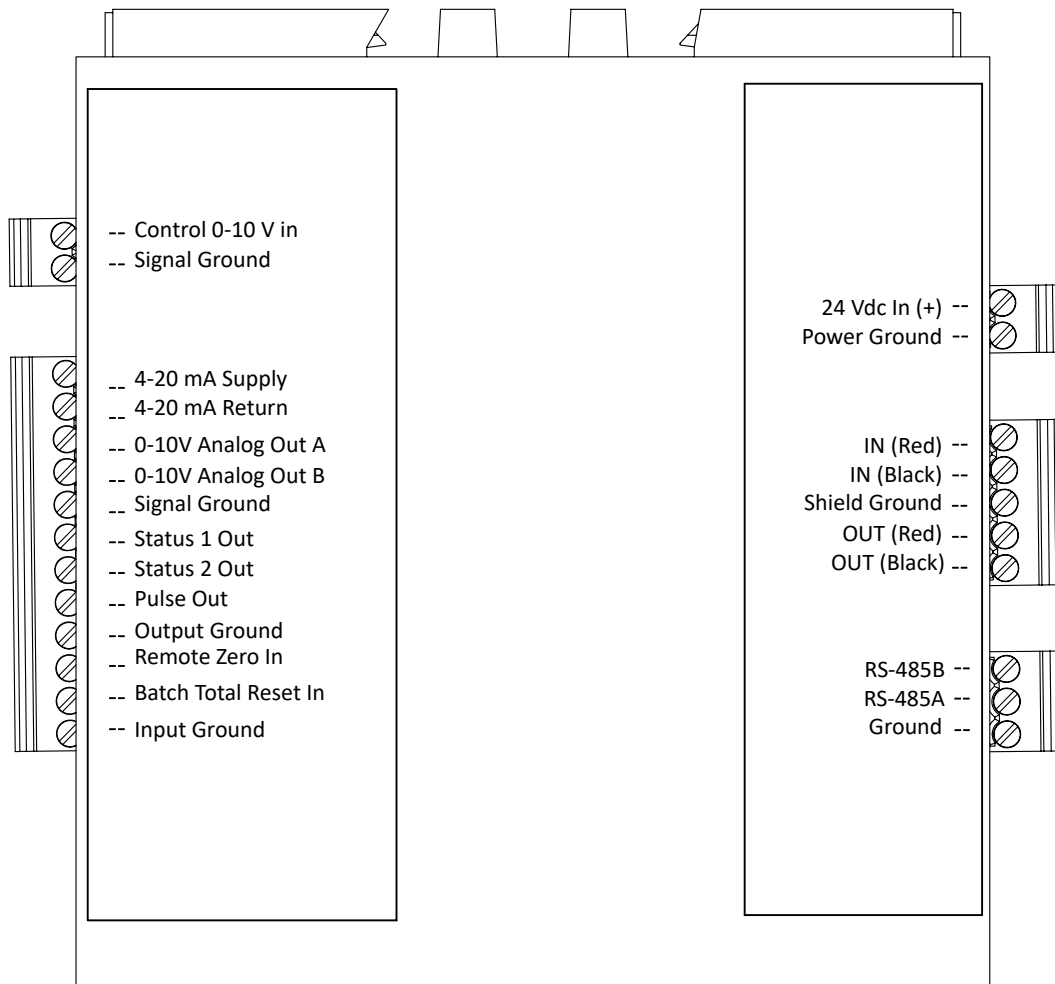

4.00 Dimension Drawing

4.01 Flow Detectors

M-2111 (04 / 06)

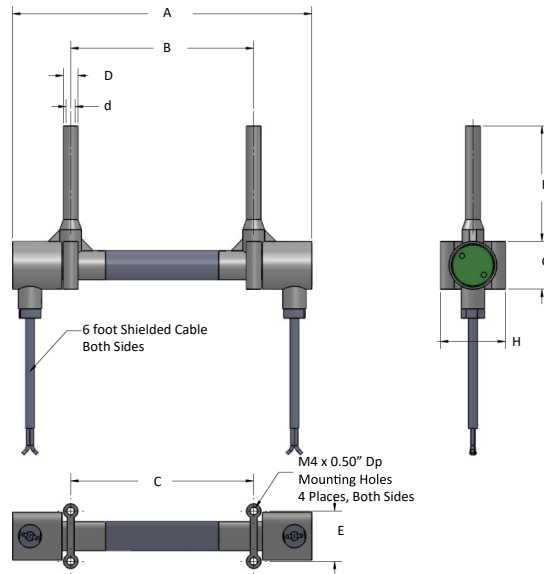

M-2111 (10 / 15 / 20)

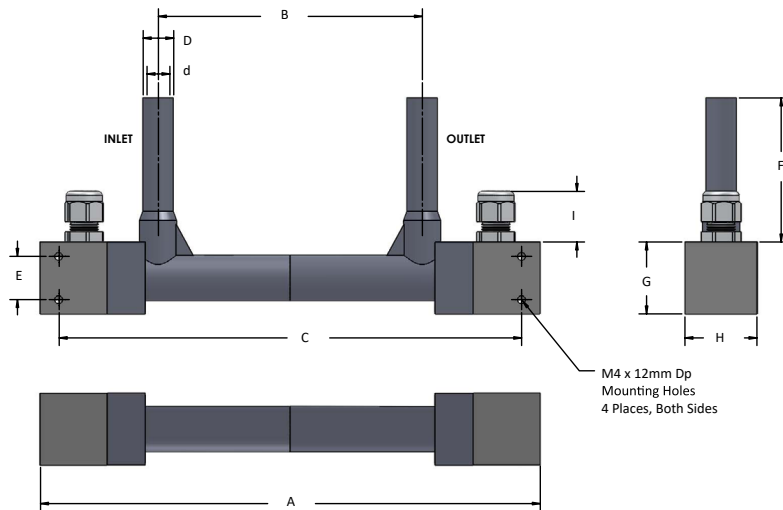

Range Code	Connecting Tube Size	Dimensions (inch)									
		D	d	A	B	C	E	F	G	H	I
04	1/4"	0.25	0.156	5.1	3.1	3.1	0.9	2	0.8	1.1	-
04	3/8"	0.375	0.25	5.1	3.1	3.1	0.9	2.7	0.8	1.1	-
06	3/8"	0.375	0.25	5.9	3.9	3.9	0.9	2.7	0.8	1.1	-
10	1/2"	0.5	0.375	8.2	4.3	7.6	0.7	2.4	1.2	1.2	0.8
15	3/4"	0.75	0.625	11.3	6.5	10	1	1.7	1.6	1.6	0.8
20	1"	1	0.876	13.7	8.7	12.2	1	2.1	1.6	1.6	0.8

4.00 Dimension Drawing

4.02 Converter Without Display

Model: USC-B01 (dimensions in inches)

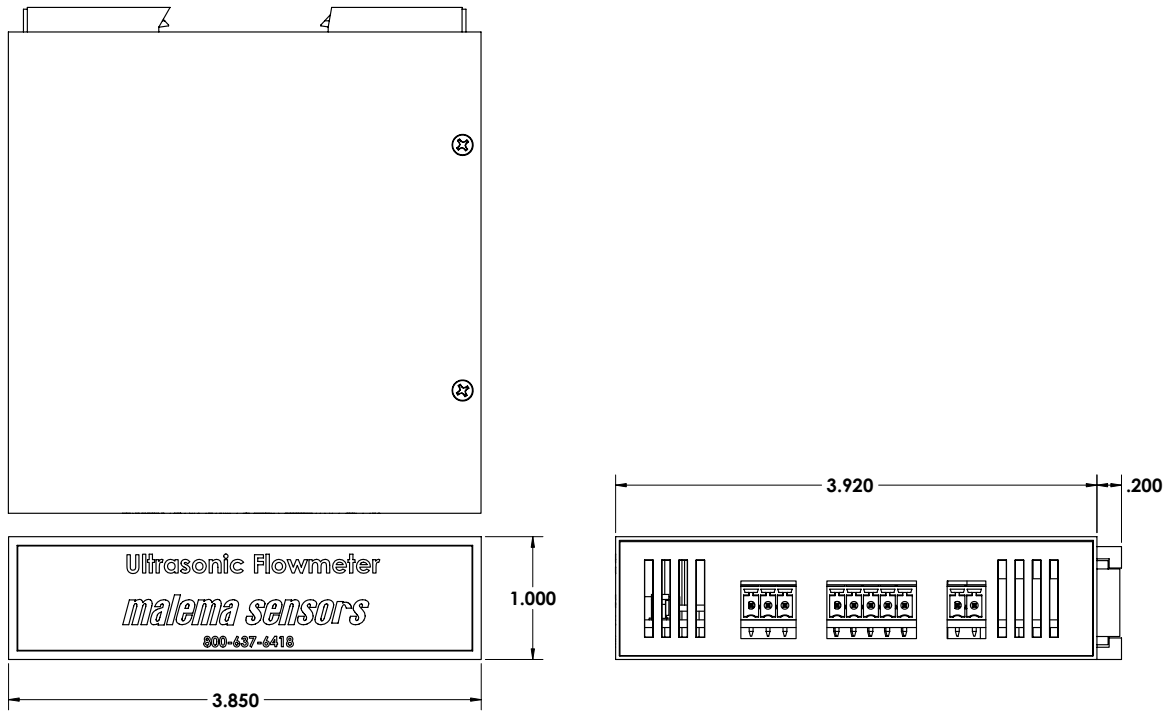

4.03 Converter With Display

Model: USC-D01 (dimensions in inches)

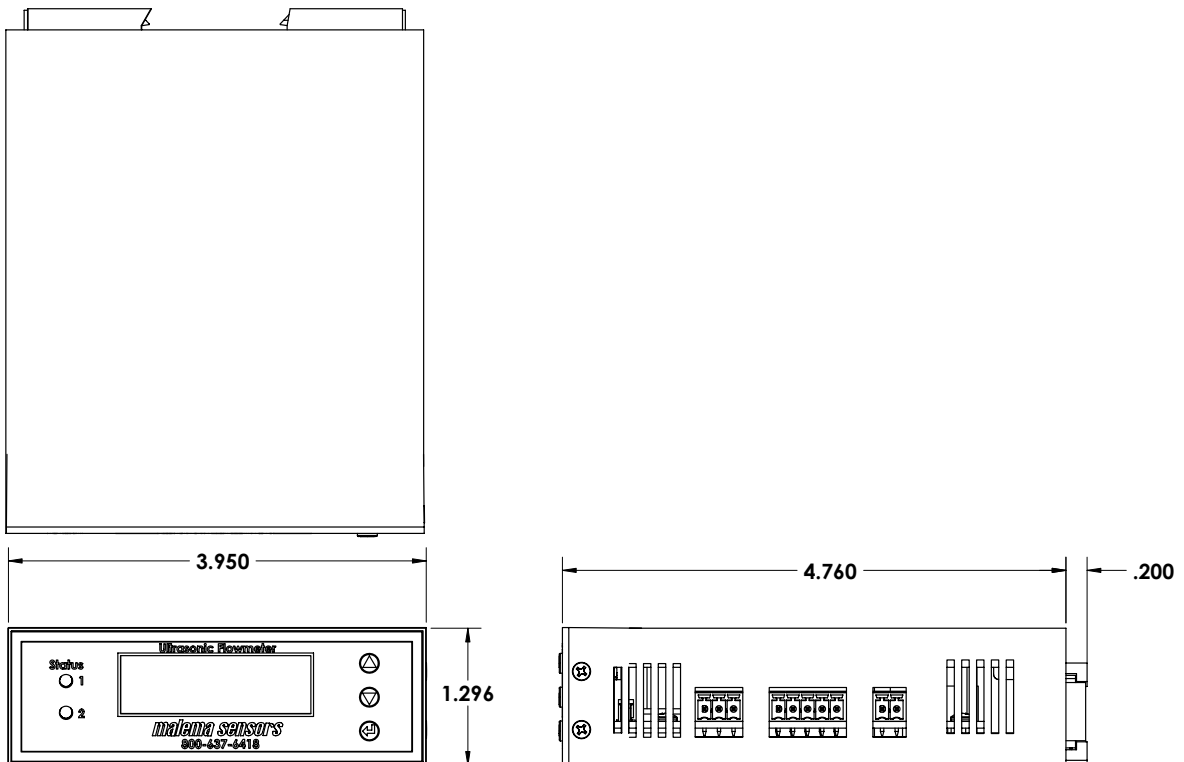

5.00 Ordering Information

Model Ordering Code											Description	
M-2111	-	F	*	*	**	-	*	-	*	-	***	
Body Material		F										PFA
Connection Size (OD)			2									1/4"
			3									3/8"
			4									1/2"
			6									3/4"
			8									1"
Connection Type			1									Tube Ends
			2									Flare
			3									Pillar Super 300
Range Code				04								3 l/min
				06								8 l/min
				10								20 l/min
				15								50 l/min
				20	-							80 l/min
					-							
Converter							D					DSP Converter with display
							B					DSP Converter with display
								-				
Geometry								U				U - Shape
								Z				Z - Shape
									-			
										XXX		Unique PN identifier

6.00 Maintenance

Ultrasonic flow meter requires no daily maintenance since it has no moving parts that can be subject to wear and tear. However, we recommend the following checks to ensure smooth and reliable operation.

Connection of Flow Detector

- Check for leakage around pipe connections or liquid penetration into Flow Detector tube.
- Check for any loose nuts.
- Make sure that the connection ports are leak free.

Connecting Pipe

- Check for mechanical stress to Flow Detector caused by possible warping of connecting pipes or loose connections caused by heavy pipe vibration.

Cable Connector

- Check cable connector of Flow Detector and tighten them if loose.
- Observe the Flow Detector visually from outside and note that there are no sediments, bubbles, or foreign materials in the measuring tube.

7.00 Warranty

PSG Biotech warrants to the buyer that its products are free from defects in materials and workmanship at the time of shipment and during the WARRANTY PERIOD. Seller's obligation under this warranty is limited to the replacement of the product(s) by same product(s) manufactured by PSG or repair of the product(s) at the facility.

PSG Biotech products are sold with the understanding that the buyer has determined the applicability of the product(s) to its intended use. It is the responsibility of the buyer to verify acceptability of performance to the actual conditions of use. Performance may vary depending upon these actual conditions.

Warranty Period

This warranty is in effect for twelve (12) months from the date of shipment from PSG manufacturing location.

Warranty Claim

If PSG Biotech products are found to be defective in materials or workmanship within twelve (12) months of the date of shipment, they will be repaired or replaced with same product at the discretion of PSG at its place of business at no charge to the buyer.

8.00 Service Contacts

For service support or technical assistance, please contact the PSG Biotech Technical Support Team at:

Telephone: +1 (800) 637-6418
+1 (408) 970-3419

E-mail: Malema.technicalsupport@psgdover.com

9.00 Service and Repair

To return the products, please obtain an RMA number for the product by contacting 2329 Zanker Road, San Jose, CA 95131, at +1 (800) 637-6418 or +1 (408) 970-3419, or email Malema.technicalsupport@psgdover.com

Unless otherwise specified with the RMA number, all equipment must be returned to the following address:

PSG San Jose
2329 Zanker Road
San Jose, CA 95131, USA

Note: Flow sensors cannot be returned once exposed to gamma radiation.



Florida
1060 S Rogers Circle
Boca Raton, Florida 33487
Telephone: 1-800-637-6418

California
2329 Zanker Road
San Jose, California 95131
Telephone: 1-408-970-3419

India
1st, 3rd and 4th Floor, # 1433,
Pipeline Road Mahalakshmi
Puram, Bengaluru, India 560086
Telephone: 91-80-23499-362