

Brand Portfolio

Centrifugal Pump Solutions for Critical Applications



Where Innovation Flows



Who We Are



Griswold®, a product brand of PSG®, a Dover Company, is a premier manufacturer of centrifugal pumps and baseplate systems. Griswold provides world-class engineering expertise, lean manufacturing, testing capabilities and exceptional customer support to meet customers' most demanding application requirements. Backed by a world-class testing facility and quality procedures, Griswold centrifugal pumps have the ability to withstand the most demanding application requirements while minimizing project costs.

Industry Knowledge & Experience

Knowledge

Griswold is a veteran in the pump industry, with product lines dating back over 70 years. You'll find a wealth of industry knowledge and experience behind every Griswold product. With more than 100,000 pump installations worldwide and an international distribution network, Griswold excels in a broad range of chemical processing, industrial and municipal applications.

Customer Satisfaction

The main focus at Griswold is your success, and this commitment extends way beyond our top-of-the-line products. We have structured our staff, systems and inventory to deliver consistent high-level solutions for meeting your most critical equipment and time-sensitive delivery needs. Griswold also offers state-of-the-art certified performance testing (witnessed and non-witnessed) that conforms to Hydraulic Institute (HI) standards. We pride ourselves in providing what you need when you need it.

Markets Served

With a proven track record of performance and long-term reliability, Griswold centrifugal pumps overcome unique operational challenges across the energy, process and water/wastewater industries in the safest, most efficient and profitable way possible. Our market expertise and technical experience across these industries and applications allows us to work closely with our partners and customers to solve the complex industrial application issues that they encounter.



World-Class Manufacturing and Testing Facility

Supply Chain

Every component that goes into a Griswold pump is put through a rigid Production Part Approval Process (PPAP) that ensures quality and reliability.

Quality Manufacturing

The Griswold facility is ISO 9001/14001 compliant with state-of-the-art coordinate-measuring machines and 3D-scanning equipment ensuring the highest level of part quality.

Testing Capabilities

Griswold's World-Class Test Facility is certified by the Hydraulic Institute (HI) Pump Test Lab Approval Program (PTLAP). PTLAP is designed to provide the opportunity to demonstrate compliance with established quality program, procedures, instrument calibration and pump testing to HI 40.6 Methods of Rotodynamic Pump Efficiency Testing. Griswold's testing facility allows pumps to be tested at additional capacity with higher flow rates and is set up for automated performance and vibration testing.



What Drives Your Pump Selection?

In a rapidly changing world market, there's no longer room for making business decisions based on convention or old relationships. Every angle must be scrutinized to give your production process the edge needed to survive economic volatility and polarizing competition. Maximizing production and minimizing costs are as much functions of equipment performance as initial and long-term costs of operating and maintaining equipment. Additionally, you must minimize the time and financial losses caused by production failures.

As a result of more severe applications and the requirement to reduce costly labor, pump specifications must meet more than the demanding criteria of ANSI or NSF compliance. In a world where you need every advantage – we're confident you'll choose Griswold. With a proven track record of performance, extended equipment life, reduced initial cost and total cost of ownership, Griswold pumps are unmatched by any other pump manufacturer.

Flexibility

In a world with unique environments and applications, Griswold remains small enough to accommodate your every need. Griswold makes your pump a trouble-free investment by offering close-coupled and frame mounted power options, custom impeller trims, explosion proof motors, premium base plates, a variety of seal choices, seal flush options and certified performance testing, and even expedited delivery.





Centrifugal
Technology



811 ANSI Series ASME (ANSI) B73.1 Centrifugal Pumps

The 811 ANSI Series is available in a wide range of sizes, capacities and materials to fit virtually any process-fluid application. With more than 30 selections and multiple design options, we've got your application covered – for abrasives, corrosive substances and a wide range of capacities.

Engineered for Flexibility and Durability

APPLICATIONS:

- Oil & Gas
- Chemical
- Petrochemical
- Water Treatment
- Pulp & Paper
- Breweries
- Grain Processing
- Food Processing
- Poultry Processing
- Automotive
- Pharmaceutical
- Steel
- Semiconductor
- Power Generation
- Textile

FEATURES AND BENEFITS:

- ASME (ANSI) B73.1-compliant
- Magnetic drain plug
- Extra-large capacity epoxy-coated oil sump
- Registered alignment between frame and adapter
- Standard and low-flow models available
- Heavy-duty power frames
- Fully open impellers with rear-adjustment capability
- Wide variety of mechanical seal options
- Dynamically balanced impellers

TECHNICAL DATA:

- Ductile iron, CF8M (316) stainless steel, CD4MCuN and Alloy 20 materials available
- Max. temperature: 260°C (500°F)
- Three stuffing-box options available
- Multiple port sizes available
- Multiple seal-flush plans available
- Steel and composite baseplates available
- Certified testing per Hydraulic Institute and material certifications per ASTM

PERFORMANCE DATA:

- Max. flow: 7,000 gpm (1,590 m³/hr)
- Max. head: 900 ft (275 m)
- Max. working temperature: 500°F (260°C)

CERTIFICATIONS:

Member of   
ASME (ANSI) B73.1

1 Ductile Iron Frame Adapters

Ductile-iron construction provides strength and safety. Precision machined to accurately align the liquid end to the power end. Large openings simplify installation and maintenance. Includes jacking bolts to facilitate disassembly.

2 Labyrinth Seals Standard

INPRO® oil seals keep outside contaminants from lubrication media, significantly extending bearing life. Standard in bronze. Carbon-filled PTFE (Teflon®) and magnetic face seals optional.

3 Mounting Frame Flange

Machined to accommodate C-face motor adapters.

4 Extra-Large Capacity Powder-Coated Oil Sump

Maximized oil capacity delivers improved heat transfer and oil temperature, greatly extending bearing life. Designed to accommodate optional fin coolers for high-temperature applications. Impenetrable fusion-bonded epoxy coating on interior surface extends quality, cleanliness and longevity of the lubricating oil.

5 External Clearance Adjustment

Designed for maintaining original flow, pressure and efficiency, minimizing energy consumption and repairs, and extending mean time between repairs (MTBR).

6 Heavy-Duty Shaft and Bearings

Engineered to minimize vibration and shaft deflection, less than 0.002 inch per ANSI/ASME B73.1, optimizing pump life. Sleeved and solid shaft available in a variety of materials. Bearings sized for 10-year life expectancy under tough operating conditions.

7 Oversized Sight Glass

One-inch bullseye reflective sight glass facilitates monitoring oil level and condition, critical to bearing life. Bottle oiler optional.

8 Magnetic Drain Plug

Collects damaging metallic contaminants away from the bearings.

9 Extra-Heavy Casings

All Class 150 pumps are produced with the same heavy-duty wall thicknesses as Class 300 pumps for extended reliability and casing life under severe corrosive/erosive conditions:

- Top centerline, self-venting discharge for air handling
- Back pullout to simplify maintenance
- Rigid casing feet prevent pipe-load misalignment and promote seal/casing life
- Discharge connection for pressure gauge or seal bypass-flush connection standard on ductile iron and stainless steel casings
- Class 150 FF standard for positive sealing; optional Class 150 RF/300 FF/RF available
- Casing drain standard in ductile iron and stainless steel for simplified maintenance

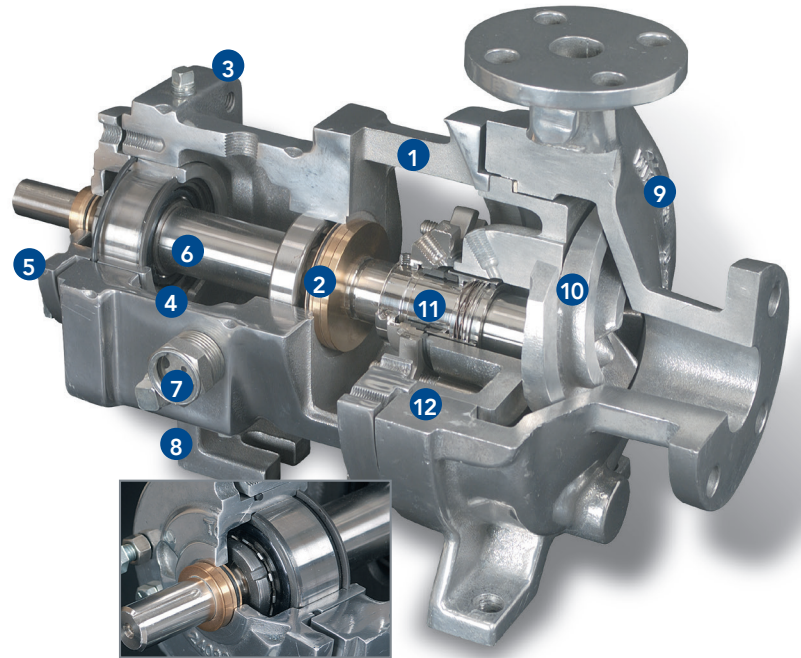

10 Fully Open Impeller

With double the wear area of enclosed models, the 811's impeller offers superior handling of solids, corrosives and abrasives. Back pump-out vanes reduce hydraulic loads and seal chamber pressure.

11 Sealing Flexibility

Wide range of sealing options coupled with seal chambers and stuffing boxes selected for service condition to improve lubrication and heat dissipation of seal faces, maximizing pump uptime.

12 Contained Casing Gasket

Provides positive sealing at casing joint to prevent "blow out" of liquids and to facilitate disassembly.





Centrifugal Technology



811SP Series

The 811SP Series is available in 8 different sizes and utilizes a CD4MCuN case as standard, making it ideal for virtually any process-fluid application. It is designed and engineered to provide flexibility and interchangeability by sharing all back-end components with Griswold's 811 ANSI Series line of ASME (ANSI) B73.1 centrifugal pumps.

Engineered for Flexibility and Durability

APPLICATIONS:

- Chemical Transfer
- Industrial Sump
- Coal Pile Drainage
- Petroleum Transfer
- Petrochemical
- Bilge Water Removal
- Tank Car Unloading

FEATURES AND BENEFITS:

- Component interchangeability with Griswold 811 ANSI Series ASME B73.1 pumps
- Designed to meet the requirement of ASME B73.1
- Extra-large capacity, epoxy-coated oil sump
- Quick priming time and easy drainage
- Dynamically balanced impellers increase pump life cycle
- Casing retains priming fluid during siphon conditions
- Heavy-duty power frames
- Magnetic power frame drain plug
- Fully open impellers with rear-adjustment capability
- Wide variety of mechanical seal options
- High-quality, genuine, certified parts
- Part-for-part interchangeability with select competitor models
- Easy retrofit from Griswold 811 ANSI Series pumps and select competitor models
- Available with steel, stainless steel, or composite baseplates
- Performance validated in a test lab certified per Hydraulic Institute (HI) 14.6
- Material certifications per ASTM
- Easy service of one-piece casing with access holes

TECHNICAL DATA:

- Max. flow: 1,300 gpm (295 m³/hr)
- Max. head: 380 ft (115 m)
- Max. temperature: 500°F (260°C)
- Casing pressure ratings meeting pressure ratings of Class 150 flanges
- Effective static lifts to 25 ft (7.5 m)

CERTIFICATIONS:



1 Ductile Iron Frame Adapters

Ductile-iron construction provides strength and safety. Precision machined to accurately align the liquid end to the power end. Large openings simplify installation and maintenance. Includes jacking bolts to facilitate disassembly.

2 Labyrinth Seals Standard

INPRO® oil seals keep outside contaminants from lubrication media, significantly extending bearing life. Standard in bronze. Carbon-filled PTFE and magnetic face seals optional.

3 Mounting Frame Flange

Machined to accommodate C-face motor adapters.

4 Extra-Large Capacity Powder-Coated Oil Sump

Maximized oil capacity delivers improved heat transfer and oil temperature, greatly extending bearing life. Designed to accommodate optional fin coolers for high-temperature applications. Impenetrable fusion-bonded epoxy coating on interior surface extends quality, cleanliness and longevity of the lubricating oil.

5 External Clearance Adjustment

Designed for maintaining original flow, pressure and efficiency, minimizing energy consumption and repairs, and extending mean time between repairs (MTBR).

6 Heavy-Duty Shaft and Bearings

Engineered to minimize vibration and shaft deflection, less than 0.002 inch per ASME (ANSI) B73.1, optimizing pump life. Sleeved and solid shaft available in a variety of materials. Bearings sized for 10-year life expectancy under tough operating conditions.

7 Oversized Sight Glass

One-inch bullseye reflective sight glass facilitates monitoring oil level and condition, critical to bearing life. Bottle oiler optional.

8 Magnetic Drain Plug

Collects damaging metallic contaminants away from the bearings.

9 Self-Priming Casing

- Integral priming chamber one-piece casing design
- Top centerline self-venting discharge
- Back pull-out to simplify maintenance
- Rigid casing feet prevent pipe-load misalignment and promote seal/casing life
- Provisions for discharge and suction flange taps for gauge and seal flush connections
- Class 150 FF flanges with serrated finish are standard for positive sealing, Class 150 RF / 300 FF/RF available
- Casing drain is standard for simplified maintenance

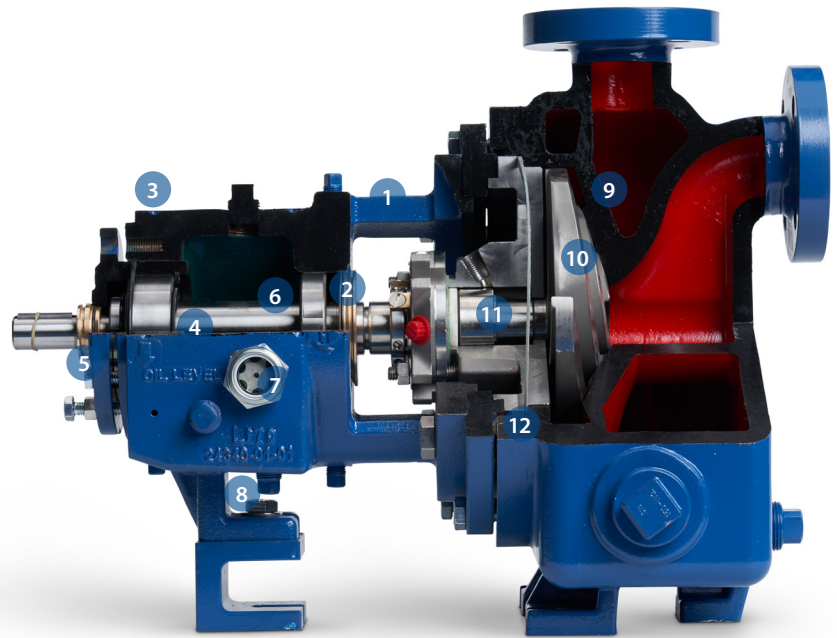

10 Fully Open Impeller

With double the wear area of enclosed models, the 811SP Series impeller offers superior handling of solids, corrosives and abrasives. Back pump-out vanes reduce hydraulic loads and seal chamber pressure.

11 Sealing Flexibility

Wide range of sealing options coupled with seal chambers and stuffing boxes selected for service condition to improve lubrication and heat dissipation of seal faces, maximizing pump uptime.

12 Contained Casing Gasket

Provides positive sealing at casing joint to prevent "blow out" of liquids and to facilitate disassembly.





850 Series Industrial Water Centrifugal Pumps

Griswold 850 Series pumps have been specifically designed with versatility in mind. Thanks to their efficient performance, extensive features, long life and easy maintenance, these pumps are ideal for use in a wide variety of water applications. Griswold 850 Series pumps feature capacities up to 3,850 gpm (874 m³/hr), heads to 430 ft (131 m), and a broad range of sizes and configuration options.

Engineered for Flexibility and Durability

FEATURES AND BENEFITS:

- NSF® 50 & NSF 61 Certified
- Heavy-duty, robust design
- Flanged connections in accordance with ASME B16.1
- Single-piece enclosed impellers
- Back pull-out design for ease of maintenance
- Component mechanical seals
- Iron liquid path
- Renewable lead-free bronze wearing rings
- Close-coupled or frame-mounted options
- Close-coupled NEMA electric motors available
- Frame-mounted with coupling to: electric motors, engines, steam turbines, or belt-driven options
- Base mounted options
- Epoxy-coated interior (optional feature)

OPTIONS:

- Close-coupled configuration
- Frame-mounted configuration
- Epoxy coating for corrosion protection
- Seal material options
- Baseplate mounting systems

PERFORMANCE DATA:

- Max. flow 3,850 gpm (874 m³/h)
- Max. head: 430 ft. (131 m)
- Max. working temperature: 120°F (49°C)

CERTIFICATIONS & ASSOCIATIONS:



1 Flanged Iron Casing

The 850 Series iron casing is tapped for a drain, vent and pressure gauge. It includes a suction wear ring and can be rotated to various discharge positions. Standard ASME B16.1 flange-type suction and discharge nozzles facilitate installation and maintenance.

2 Renewable Lead-Free Bronze Shaft Sleeve

The renewable lead-free bronze shaft sleeve insulates the shaft from abrasion and contact with pumped liquids.

3 Mechanical Shaft Seals

Mechanical shaft seals feature Carbon/Ceramic/Buna-N and Stainless-Steel components, eliminating maintenance and adjustment problems.

4 Renewable Lead-Free Bronze Wearing Rings

Precision-made lead-free bronze wearing rings are pressed into the casing and/or bracket as required and are renewable, as well as easily replaced in the field.

5 Single-Piece Enclosed Impeller

Made of aluminum bronze and keyed to the shaft, the single-piece enclosed impeller is precision balanced with the diameter cut for the specific condition point. On high-head units, the impeller back is drilled for hydraulic balance, limiting thrust load and reducing pressure in the sealing area. Aluminum bronze is a preferred material over stainless steel for its durability and superior corrosive resistance, especially in chlorine applications.

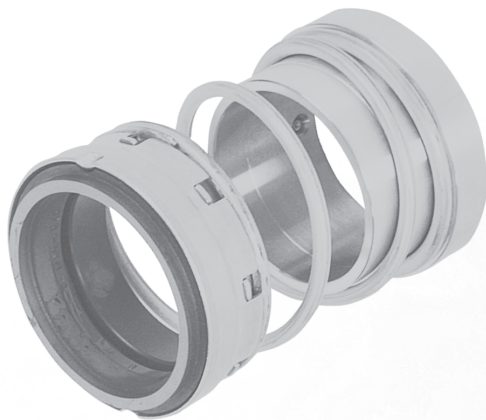
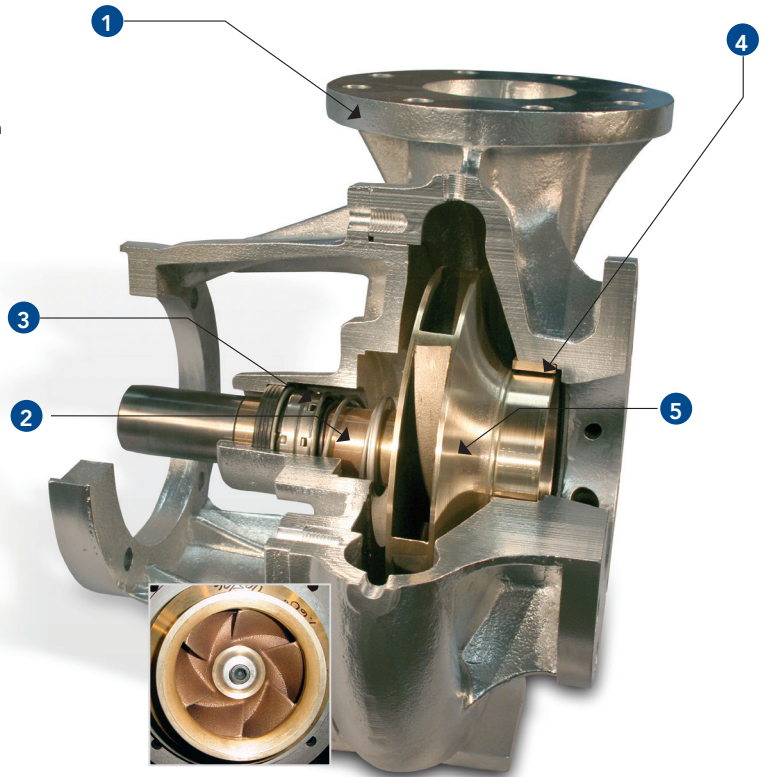

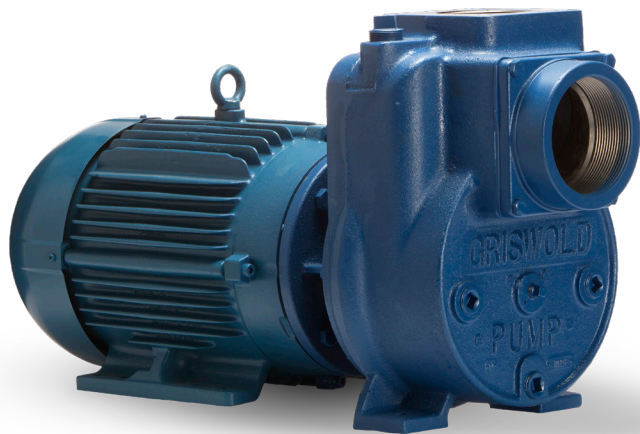

H Series Self-Priming Centrifugal Pumps

H Series pumps are a unique line of self-priming centrifugal pumps used for a variety of water applications. The H Series performs where other self-priming pumps can't, and have been designed specifically to lift water up to 25 feet.

Engineered for Flexibility and Durability

APPLICATIONS:

- Draining Barges
- Tank Cars
- Underground Storage Facilities
- Sprinkler Systems
- Swimming Pools
- Marine
- Water Sumps
- Available with a variety of drives
- Heavy-duty cast iron bronze fitted construction
- Close-coupled JM Frame ODP or TEFC motors available
- Options available for seal materials, frame-mount options, motors, and more

FEATURES AND BENEFITS:

- Built-in check valve
- Maintain prime even when check valves or foot valves have failed
- High suction line keeps impeller and mechanical seal covered with water, eliminating the need to reprime the pump, as well as protects the seal from running dry

PERFORMANCE DATA:

- Max. flow: 325 gpm (73.8 m³/h)
- Max. head: 260 ft (79 m)
- Max. working temperature: 100°F (37.8°C)

1 NPT/Flanged Discharge Connection

Discharge Dual Connections – Both pumps can be connected by either NPT threads or ANSI flanges.

2 JM Frame ODP or TEFC Motors

The renewable lead-free bronze shaft sleeve insulates the shaft from abrasion and contact with pumped liquids.

3 Standard Carbon/Ceramic/Buna Mechanical Seal

Carbon and ceramic faces available, plus stainless-steel components eliminate maintenance problems. Other seal options are available. Hard Faced Options Available.

4 Totally Enclosed, Single-Piece Design, Cast Bronze Impeller

Bronze, single-piece design impeller is balanced and trimmed for specific operating range.

5 3/4" NPT Accessory Connections

6 Heavy-Duty Cast Iron Casing

Heavy-duty cast iron ASTM A48 class 30 case with built-in drain and priming plugs and bolt-on suction flange. The HL and HH models also have (3) 3/4" NPT plugged connections on the case for accessories to be installed or auxiliary water outlets. Extra-large priming chamber for fast, trouble-free priming. The HL and HH models offer dual connections. Both pumps can be connected by either NPT threads or ANSI flanges on the discharge and NPT threads or Victaulic groove connections on the suction.

7 Flapper Type Check Valve

Built-In Check Valve – Prevents siphoning and need for repriming. No external check valve is required. Designed for easy replacement.

8 Above Centerline Suction Connection

9 NPT/Victaulic Suction Flange

Bolt-on suction flange available in a variety of sizes to accommodate your specific flow and horsepower requirements. The 3" flange is machined for both 3" NPTF threads and a 3" victaulic groove connection. The 4" flange is machined for 4" NPTF threads.

Thanks to a suction line located higher on the pump housing than conventional centrifugal pumps, the impeller and mechanical seal on the H Series remains covered with water at all times, eliminating the need to reprime the pump while protecting the seal from running dry and costly replacements.

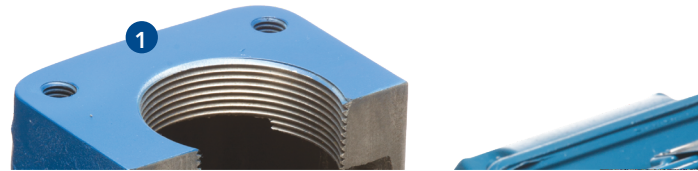

9

2

8

7

3

4

6

5



PSG
22069 Van Buren Street
Grand Terrace
CA, 92313-5651
USA



Where Innovation Flows

GRS-10001-C-09

Copyright 2026 PSG®, a Dover company

Authorized PSG® Partner: