

BLACKMER PARTS LIST

PUMP MODELS: TXD3E (Double Ended Shafts) TX3E (Single Ended Shafts)

Keep with Instructions 201-A00 for Installation, Operation and Maintenance

961815
Page 1 of 2

PARTS LIST
201-A04

Section	201
Effective	Apr 2026
Replaces	Nov 2015

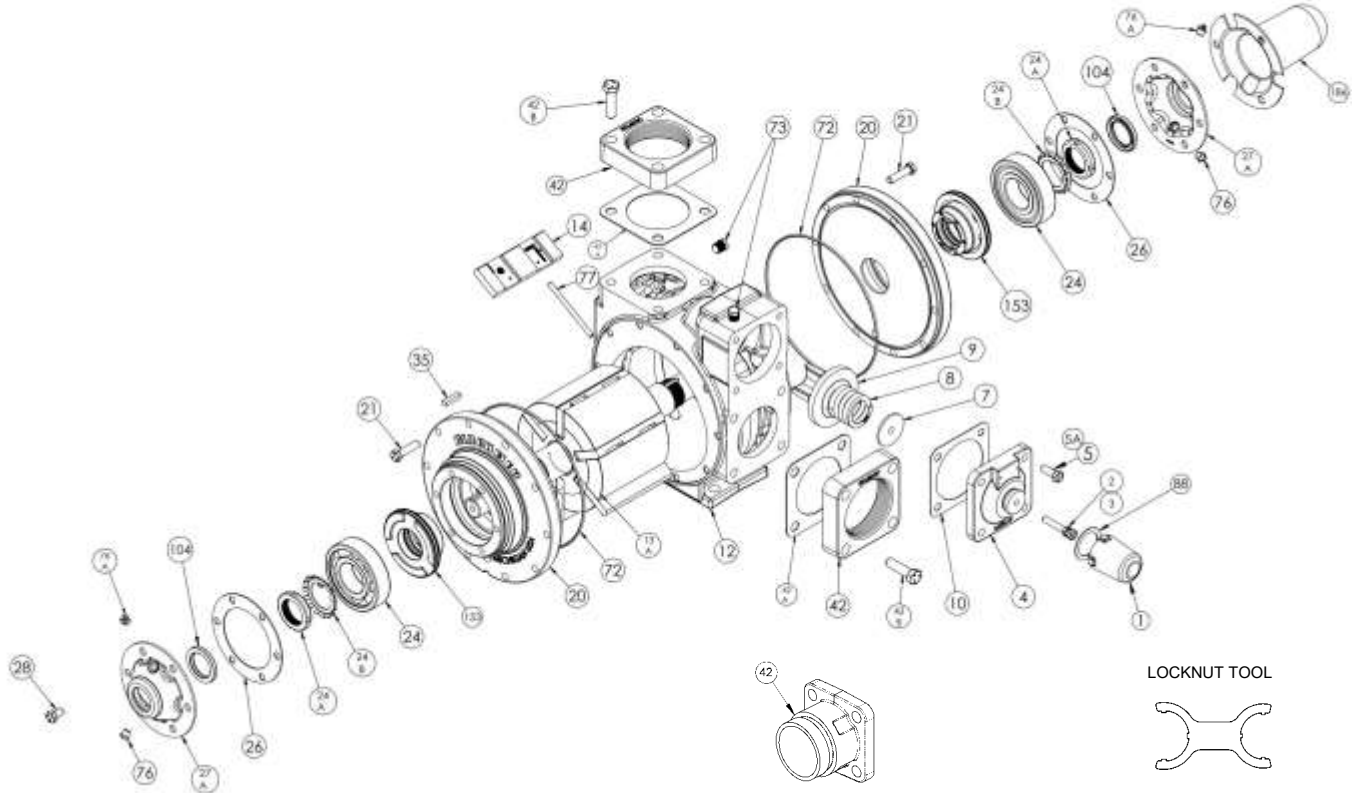

Ref. No.	Description	Parts Per Pump	Part No.	Ref. No.	Description	Parts Per Pump	Part No.
1	Cap – Relief Valve (R/V)	1	413957	26	Gasket – Bearing Cover	2	¹ 381817
2	Adjusting Screw – R/V	1	431808	27A	Bearing Cover	1 - 2	041815
3	Locknut – Adjusting Screw	1	922923		Bearing Cover - Outboard	0 – 1	041817
4	Cover – R/V	1	411807	28	Capscrews – Bearing Cover	12	920285
5	Capscrew – R/V Cover	3	920331	35	Key – Shaft	1	¹ 909178
5A	Capscrew w / Hole – R/V Cover	1	920330	42 –	Flanges, Flange Gaskets /		See
7	Spring Guide – R/V	1	421805	42C	O-rings, and Flange Capscrews		Backside
8	Spring – R/V (51-75 & 76-110 psi) (Std.)	1	471806		O-Ring - Head (FKM)	2	¹ 711938
	Spring – R/V (111-125 psi)		471809	72	O-Ring - Head (Buna-N)		¹ 701944
9	Valve - R/V ³	1	451807		O-Ring - Head (PTFE)		702233
	Valve - R/V (Nickel Plated)		451808	73	Gage Plug	2	908198
10	Gasket – R/V Cover	1	¹ 531803	76	Grease Fitting	2	317815
12	Cylinder	1	021805	76A	Grease Relief Fitting	2	701992
13A	Rotor & Shaft Assy. - Double Ended ²	1	261837	77	Push Rod	3	¹ 121807
	Rotor & Shaft Assy. - Single Ended ²		261839	88	Gasket - R/V Cap	1	¹ 533908
14	Vane – Duravane	6	¹ 091819	104	Grease Seal	1 - 2	¹ 331908
20	Head	2	031815	186	Shaft Protector	0 - 1	341801
21	Capscrews – Head	20	920369		Air Valve Kit – Piston Type		891728
24	Ball Bearing	2	¹ 903172		Tool - Locknut		903091
24A	Locknut – Bearing	2	903523		Maintenance Kit, FKM		898958
24B	Lockwasher - Bearing	2	¹ 903524		Maintenance Kit, Buna-N		898952

¹ Included in Maintenance Kit ² Includes ref. Nos. 24A & 24B

³ For Piston Style Air Operated RV see IOM 201-G00, Diaphragm Air RV – 201-F00, DMX Diaphragm RV – 201B-B00.

MECHANICAL SEALS

REF. NO.	PART NAME	PARTS PER PUMP	PART NO.
153	Mechanical Seal Complete - Cast Iron Stationary Seat, FKM O-Rings, Carbon Seal Face. (IVCV)	2	1 331883
	Mechanical Seal Complete - Cast Iron Stationary Seat, Carbon Seal Face, Buna-N O-Rings. (INCN)		1 331880
	Mechanical Seal Complete - Cast Iron Stationary Seat, PTFE O-Ring, Carbon Seal Face w/ PTFE Seal Ring. (IACT)		331873
153D	O-Ring - Stationary (FKM)	2	711931
	O-Ring - Stationary (Buna-N)		701936
	O-Ring - Stationary (PTFE)		702080
153L	O-Ring - Rotating (FKM)	2	701962
	O-Ring - Rotating (Buna-N)		711912
	Seal Ring - Rotating (PTFE)		**

¹ Included in Maintenance Kit

** PTFE Rotating Seal Ring is not available as a separate part.

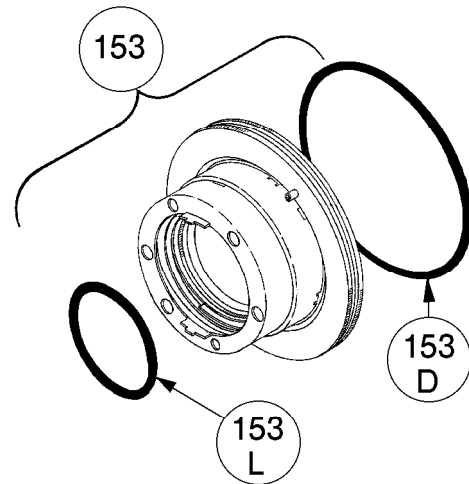

FLANGES

REF. NO.	PART NAME	PARTS PER PUMP	PART NO.
42	Flange - 3" NPT	1 - 2	651803
	Flange - 3" Weld		655102
	Flange - 3" Victaulic		655120
42A	Gasket - Flange, NPT and Weld	0 - 2	1 381816
42B	Capscrews - NPT Flange	4 - 8	920532
	Capscrews - Weld & Victaulic Flange		920510
42C	O-Ring - Victaulic Flange (Buna-N)	0 - 2	702002
	O-Ring - Victaulic Flange (FKM)		711931
	O-Ring - Victaulic Flange (PTFE)		702080

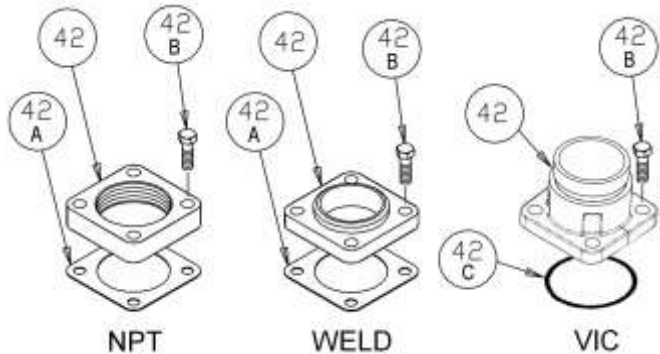

OPTIONAL HYDRAULIC MOTOR ADAPTER

REF. NO.	PART NAME	PARTS PER PUMP	PART NO. 1-1/4" Hyd Motor Shaft	PART NO. 1" Hyd Motor Shaft
	Hydraulic Motor Adapter Kit *		895140	895143
26A	Gasket - Hydraulic Motor Adapter	1	381817	381817
28A	Capscrew - Hydraulic Motor Adapter / Head	6	920369	920369
34	Coupling w/ Setscrew - straight key hydraulic motor	1	906967	906990
35	Key - Coupling	1	909184	909184
76	Grease Fitting	1	317815	317815
76A	Grease Relief Fitting	1	701992	701992
135	Hydraulic Motor Adapter - SAE A Flange	1	041831	041831
135A	Capscrew - Adapter / Motor	2	920510	920510

* Hydraulic Motor Adapters shipped prior to Spring 2002 were a two piece design - refer to page 206-B00.

