

# BLACKMER GEAR PUMP

PARTS LIST

MODELS: E1-133 and E1-222

Keep with Instructions 1901-a00 for Installation, Operation and Maintenance

960713

INSTRUCTIONS NO. 1901-a04

Section	1901
Effective	June 2025
Replaces	Sept 2024

# E Series Seal-less Internal Gear Pumps

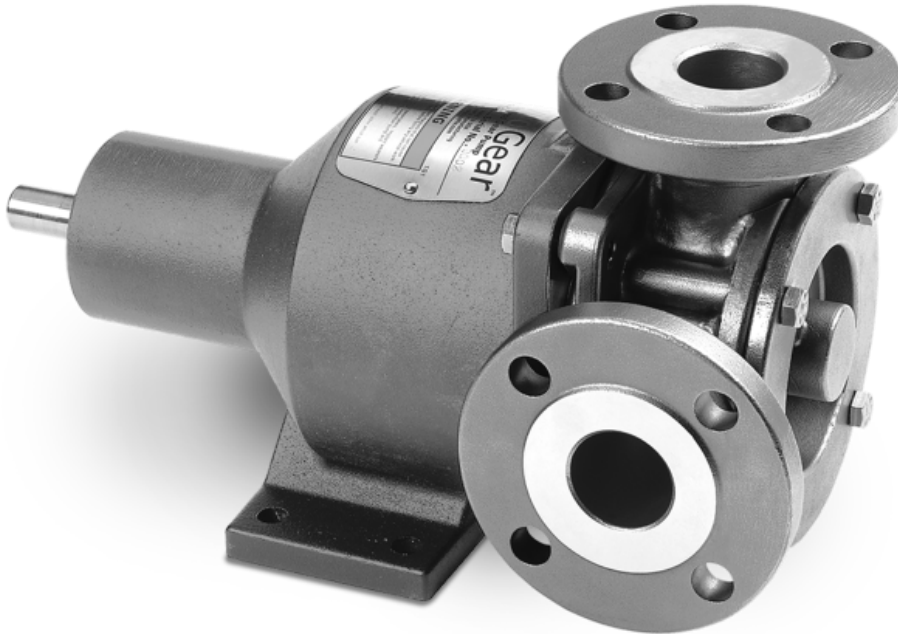

Where Innovation Flows



Always read the most current version of this manual before performing any work on or around this pump. The most current version of this manual is freely available on the web at [www.blackmer.com](http://www.blackmer.com)

Blackmer pumps are specifically configured for your unique application conditions. Those application conditions and the details of the pump configuration were documented during the ordering process. Keep that information available in a safe place, as it may be needed when troubleshooting pump problems or when ordering spare parts or repairs.

Blackmer Gear Pumps are covered by one or more of the following patents: U.S. Patent Nos. 7549205, 7137793, 7183683, 8,608,465B2 Australian Patent No. AU2005233534B2; Korean Patent No. 10-2006-7023162; Mexican Patent No. PA/2006/011436, Russian Patent No. 2006138540(041952); China Patent No. ZL 201280031563.6; and other patents pending.

# EXPLODED VIEW & PARTS LISTING

## E1-133 and E1-222 Models

E1-222 PUMP MODELS INCLUDE 6" ANSI FLANGES IN CAST IRON, CARBON STEEL AND STAINLESS STEEL. (180 DEGREE PORTING ONLY)

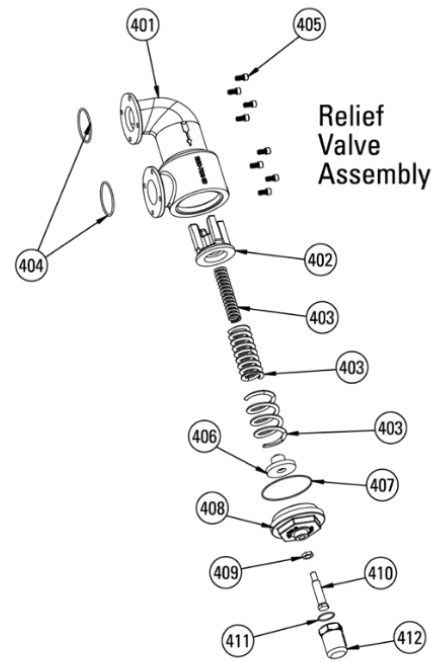
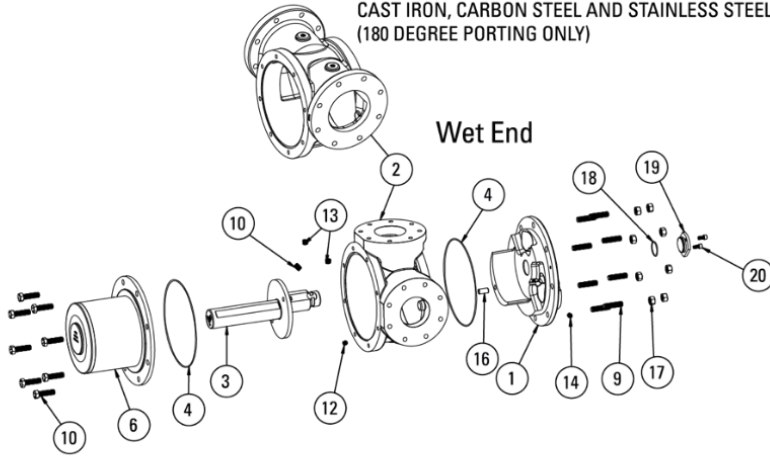

### Magnetic Housing Assembly

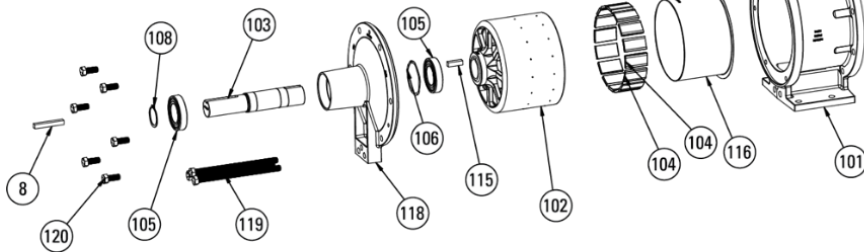

### Rotating Assemblies

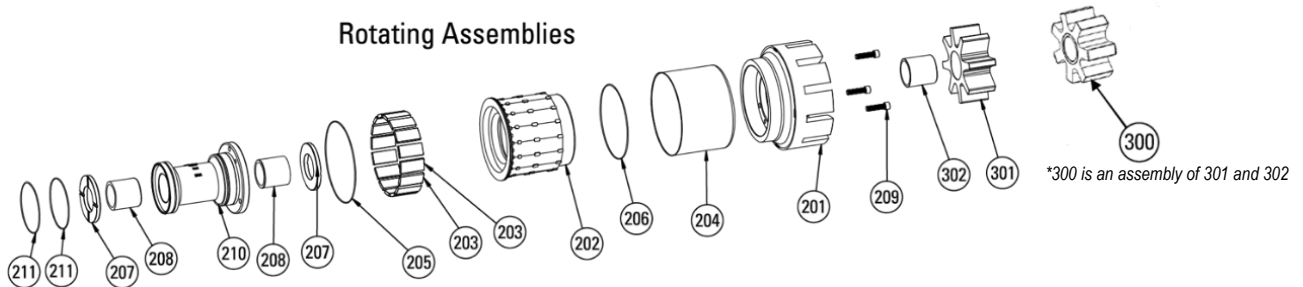

# Parts Listing

MODELS E1-133 & E1-222			CAST IRON		CARBON STEEL		STAINLESS STEEL	
Item	Description	Qty.	E1-133	E1-222	E1-133	E1-222	E1-133	E1-222
<b>WET-END</b>								
1	Head for models with RV	1	HD77	HD78	HD75	HD76	HD74	HD72
1	Head for models without RV	1	HD77	HD78	HD75	HD76	HD74	HD72
2	Casing 4" ANSI 150# ports (90° orientation)	1	CS123	NA	CS124	NA	CS118	NA
2	Casing 4" ANSI 150# ports (180° orientation)	1	NA	NA	CS143	NA	NA	NA
2	Casing 4" ANSI 300#RF ports (180° orientation)	1	NA	NA	CS144	NA	NA	NA
2	Casing 6" ANSI 150# ports (180° orientation)	1	NA	CS122	CS141	CS121	NA	CS117
2	Casing 6" ANSI 300# ports (180° orientation)	1	NA	NA	CS142	NA	NA	NA
3	Spindle hardened	1	PN80	PN82	PN80	PN82	PN81	PN83
3	Spindle	1	PN78	PN76	PN78	PN76	PN74	PN72
4	O-Ring, FKM, -276 Size	1		HW244		HW244		HW244
4	O-Ring, FEP-Encapsulated FKM, -276 Size	1		HW245		HW245		HW245
4	O-Ring, FFKM, -276 Size	1		HW246		HW246		HW246
4	O-Ring, PFA-Encapsulated Silicon, -276 Size	1		HW247		HW247		HW247
6	Canister w/Integral Support Plate	1		CN4		CN4		CN4
7	Separate Support Plate not required on E1-133 & E1-222	N/A		N/A		N/A		N/A
9	Stud, 5/8"-11 x 2.50" long	8		T09C625B50WA2A2		T09C625B50WA2A2		T09C625B50WA2A2
10	Screw, 5/8"-11 x 2.25" long	8		HW103		HW103		HW103
11	Orifice Plug, <5000 cst	1		OF1		OF1		OF1
12	Solid Setscrew, 1/2"-13 x .50" long, SS	1		HW113		HW113		HW113
13	Pipe Plug, 3/8" NPT	2		PLUG-038NSH-230		PLUG-038NSH-230		PLUG-038NSH-230
14	Pipe Plug, 1/4" NPT	1		PLUG-025NSH-230		PLUG-025NSH-230		PLUG-025NSH-230
16	Dowel Pin, 5/8" x 1.25" long, SS	1		HW252		HW252		HW252
17	Nut, 5/8"-11	8		N04C625562WA2A2		N04C625562WA2A2		N04C625562WA2A2
18	O-Ring, FKM, -132 Size	1		HW248		HW248		HW248
18	O-Ring, FFKM, -132 Size	1		HW249		HW249		HW249
18	O-Ring, PFA-Encapsulated Silicon, -132 Size	1		HW250		HW250		HW250
18	O-Ring, FEP-Encapsulated FKM, -132 Size	1		HW251		HW251		HW251
19	Head Plug	1		HP1		HP1		HP2
20	Screw, 3/8"-16 x .75" long	2		S01C375750WA2A2		S01C375750WA2A2		S01C375750AE2A1
<b>MAGNET HOUSING ASSEMBLY</b>								
101	Magnet Housing	1		MH40		MH40		MH40
102/103 /104/ 115/116	Outer Ring Assembly for M6L and M6M magnets (OR27, MS10, MS12, SH23, HW274, and SL10)	1		OR27-6L-S		OR27-6L-S		OR27-6L-S
102/103 /104/ 115/116	Outer Ring Assembly for M6H magnets (OR27, MS14, MS16, SH23, HW274, and SL10)	1		OR27-6H-S		OR27-6H-S		OR27-6H-S
102/103 /104/ 115/116	Outer Ring Assembly for M7L and M7M magnets (OR27, MS10, MS12, SH23, HW274, and SL10)	1		OR27-7L-S		OR27-7L-S		OR27-7L-S
102/103 /104/ 115/116	Outer Ring Assembly for M7H magnets (OR27, MS14, MS16, SH23, HW274, and SL10)	1		OR27-7H-S		OR27-7H-S		OR27-7H-S
103	Shaft, 1-15/16" dia	1		SH23		SH23		SH23
8	Drive Key, 1/2" x 1/2" x 1.875"	1		HW274		HW274		HW274
104	Magnet Segment, North, SC	**		MS14		MS14		MS14
104	Magnet Segment, South, SC	**		MS16		MS16		MS16
104	Magnet Segment, North, NIB	**		MS10		MS10		MS10
104	Magnet Segment, South, NIB	**		MS12		MS12		MS12
105	Ball Bearing, high temp clearance (std)	2		HW235		HW235		HW235
106	Wave Spring	1		HW242		HW242		HW242
108	Snap Ring	1		HW241		HW241		HW241
109	Pipe Plug, 1/2" NPT (Magnet Housing)	2		HW331		HW331		HW331
115	Drive Key, 1/2" x 1/2" x 1.875"	1		HW274		HW274		HW274
118	Bearing Housing	1		BH1		BH1		BH1
119	Screw, 5/8"-11 x 10" long	3		HW240		HW240		HW240
120	Screw, 5/8"-11 x 1.50" long	6		S01C625A50WA2A4		S01C625A50WA2A4		S01C625A50WA2A4
<b>ROTATING ASSEMBLIES</b>								
201	Rotor A/B	1	RT89	RT87	RT89	RT87	RT85	RT83
201	Rotor high visc clearance, C/F	1	RT92	RT98	RT92	RT98	RT95	RT101
201	Rotor high temp clearance, D/E	1	RT93	RT99	RT93	RT99	RT96	RT102

MODELS E1-133 & E1-222			CAST IRON		CARBON STEEL		STAINLESS STEEL	
Item	Description	Qty.	E1-133	E1-222	E1-133	E1-222	E1-133	E1-222
202	Inner Ring	1	IR10		IR10		IR8	
203	Magnet Segment, North, SC	**	MS15		MS15		MS15	
203	Magnet Segment, South, SC	**	MS17		MS17		MS17	
203	Magnet Segment, North, NIB	**	MS11		MS11		MS11	
203	Magnet Segment, South, NIB	**	MS13		MS13		MS13	
204	Sleeve	1	SL11		SL11		SL11	
205	O-Ring, FKM, -173 Size	1	HW232		HW232		HW232	
205	O-Ring, FEP-Encapsulated FKM, -173 Size	1	HW259		HW259		HW259	
205	O-Ring, FFKM, -173 Size	1	HW260		HW260		HW260	
205	O-Ring, PFA-Encapsulated Silicon, -173 Size	1	HW261		HW261		HW261	
206	O-Ring, FKM, -170 Size	1	HW231		HW231		HW231	
206	O-Ring, FEP-Encapsulated FKM, -170 Size	1	HW256		HW256		HW256	
206	O-Ring, FFKM, -170 Size	1	HW257		HW257		HW257	
206	O-Ring, PFA-Encapsulated Silicon, -170 Size	1	HW258		HW258		HW258	
207	Thrust Bushing, TC	2	BU149		BU149		N/A	
207	Thrust Bushings, Bronze	2	BU146		BU146		N/A	
207	Thrust Bushing, CG	2	BU150		BU150		BU150	
207	Thrust Bushing, ROC Carbon	2	BU147		BU147		BU147	
207	Thrust Bushing, Cast Iron	2	BU148		BU148		N/A	
208	Radial Bushing, TC	2	1330-2800-340		1330-2800-340		N/A	
208	Radial Bushing, Bronze	2	1330-2800-320		1330-2800-320		N/A	
208	Radial Bushing, CG	2	1330-2800-300		1330-2800-300		1330-2800-300	
208	Radial Bushing, ROC Carbon	2	1330-2800-302		1330-2800-302		1330-2800-302	
208	Radial Bushing, Cast Iron	2	1330-2800-114		1330-2800-114		N/A	
209	Socket Head Cap Screw, 1/2"-13 x 2" long	3	HW230		HW230		HW230	
210	Bushing Carrier	1	BC3		BC3		BC1	
211	O-Ring, FKM, -160 Size	2	HW233		HW233		HW233	
211	O-Ring, FEP-Encapsulated FKM, -160 Size	2	HW253		HW253		HW253	
211	O-Ring, FFKM, -160 Size	2	HW254		HW254		HW254	
211	O-Ring, PFA-Encapsulated Silicon, -160 Size	2	HW255		HW255		HW255	
300	Idler and bushing assembly, bronze, high visc (C/F) clearance	1	ID67B		ID67B			
300	Idler and bushing assembly, TC, high visc (C/F) clearance	1	ID67T		ID67T			
300	Idler and bushing assembly, CG, high visc (C/F) clearance	1	ID67C		ID67C		ID69C	
300	Idler and bushing assembly, ROC Carbon, high visc (C/F) clearance	1	ID67RC		ID67RC		ID69RC	
301	Idler A/B	1	1330-5100-121	2220-5100-121	1330-5100-121	2220-5100-121	1330-5100-176	2220-5100-176
301	Idler high visc clearance, C/F	1	ID67	ID71	ID67	ID71	ID69	ID73
301	Idler high temp clearance, D/E	1	ID68	ID72	ID68	ID72	ID70	ID74
302	Radial Bushing, TC	1	1330-5800-340	2220-5800-340	1330-5800-340	2220-5800-340	N/A	N/A
302	Radial Bushing, Bronze	1	1330-5801-320	2220-5801-320	1330-5801-320	2220-5801-320	N/A	N/A
302	Radial Bushing, CG	1	1330-5801-300	2220-5801-300	1330-5801-300	2220-5801-300	1330-5801-300	2220-5801-300
302	Radial Bushing, ROC Carbon	1	1330-5801-302	2220-5801-302	1330-5801-302	2220-5801-302	1330-5801-302	2220-5801-302
302	Radial Bushing, Cast Iron	1	1330-5801-114	2220-5801-114	1330-5801-114	2220-5801-114	N/A	N/A
<b>RELIEF VALVE ASSEMBLY</b>								
401	Valve Body	1	1330-7100-110		1330-7100-130		1330-7100-130	
401	Valve Cover, SS (Not Shown)	2	1330-7101-250		1330-7101-250		1330-7101-250	
402	Valve Poppet	1	1330-7400-110		1330-7400-110		1330-7400-110	
403	Valve Spring, Small (Used with 50, 130, and 200 psi valves)	1	1330-7600-250		1330-7600-250		1330-7600-250	
403	Valve Spring, Medium (Used with 80, 130, and 200 psi valves)	1	1330-7601-250		1330-7601-250		1330-7601-250	
403	Valve Spring, Large (Used with 200 psi valves)	1	1330-7602-250		1330-7602-250		1330-7602-250	
404	O-Ring, FKM, -233 Size	2	HW262		HW262		HW262	
404	O-Ring, FEP-Encapsulated FKM, -233 Size	2	HW265		HW265		HW265	
404	O-Ring, FFKM, -233 Size	2	HW263		HW263		HW263	
404	O-Ring, PFA-Encapsulated Silicon, -233 Size	2	HW264		HW264		HW264	
405	Screw, 3/8"-16 x .75" long	8	S01C375750WA2A2		S01C375750WA2A2		S01C375750WA2A1	
406	Valve Spring Guide	1	1330-7500-250		1330-7500-250		1330-7500-250	
407	O-Ring, FKM, -157 Size	1	HW266		HW266		HW266	
407	O-Ring, FEP-Encapsulated FKM, -157 Size	1	HW269		HW269		HW269	
407	O-Ring, FFKM, -157 Size	1	HW267		HW267		HW267	
407	O-Ring, PFA-Encapsulated Silicon, -157 Size	1	HW268		HW268		HW268	
408	Valve Bonnet	1	1330-7201-110		1330-7201-130		1330-7201-150	
409	Valve Lock Nut	1	1330-7710-255		1330-7710-255		1330-7710-255	
410	Valve Adjustment Screw	1	1330-7700-255		1330-7700-255		1330-7700-255	
411	O-Ring, FKM, -126 Size	1	HW270		HW270		HW270	
411	O-Ring, FEP-Encapsulated FKM, -126 Size	1	HW273		HW273		HW273	

MODELS E1-133 & E1-222			CAST IRON		CARBON STEEL		STAINLESS STEEL	
Item	Description	Qty.	E1-133	E1-222	E1-133	E1-222	E1-133	E1-222
411	O-Ring, FFKM, -126 Size	1	HW271		HW271		HW271	
411	O-Ring, PFA-Encapsulated Silicon, -126 Size	1	HW272		HW272		HW272	
412	Valve Cap	1	1330-7301-110		1330-7301-130		1330-7301-150	
OPTIONS								
605	1/4" NPT Thermocouple RTD Unit, NEMA 4	1	HW219		HW219		HW219	
605	1/4" NPT Thermocouple RTD Unit, NEMA 4X SS ATEX	1	HW275		HW275		HW219	

\*\* MAGNET QUANTITIES MAY VARY DEPENDING ON PUMP CONFIGURATION



PSG Grand Rapids  
1809 Century Avenue SW  
Grand Rapids, MI 49503 USA  
P: +1 (616) 241-1611 • F: +1 (616) 241-3752  
info@blackmer.com  
blackmer.com



Where Innovation Flows

---

PSG® reserves the right to modify the information and illustrations contained in this document without prior notice. This is a non-contractual document. 05-2018