



TYPE	SIZE	UNIT STYLE
SX	3	SK871

PARTS LIST 104-H16	
Section Effective Replaces Page 1 / 1	104 JAN 2024 NEW

RIGHT HAND ROTATION SHOWN. FOR LEFT HAND ROTATION, SHAFT IS OPPOSITE THAT SHOWN.

MOUNTING STYLE: LONG COUPLED

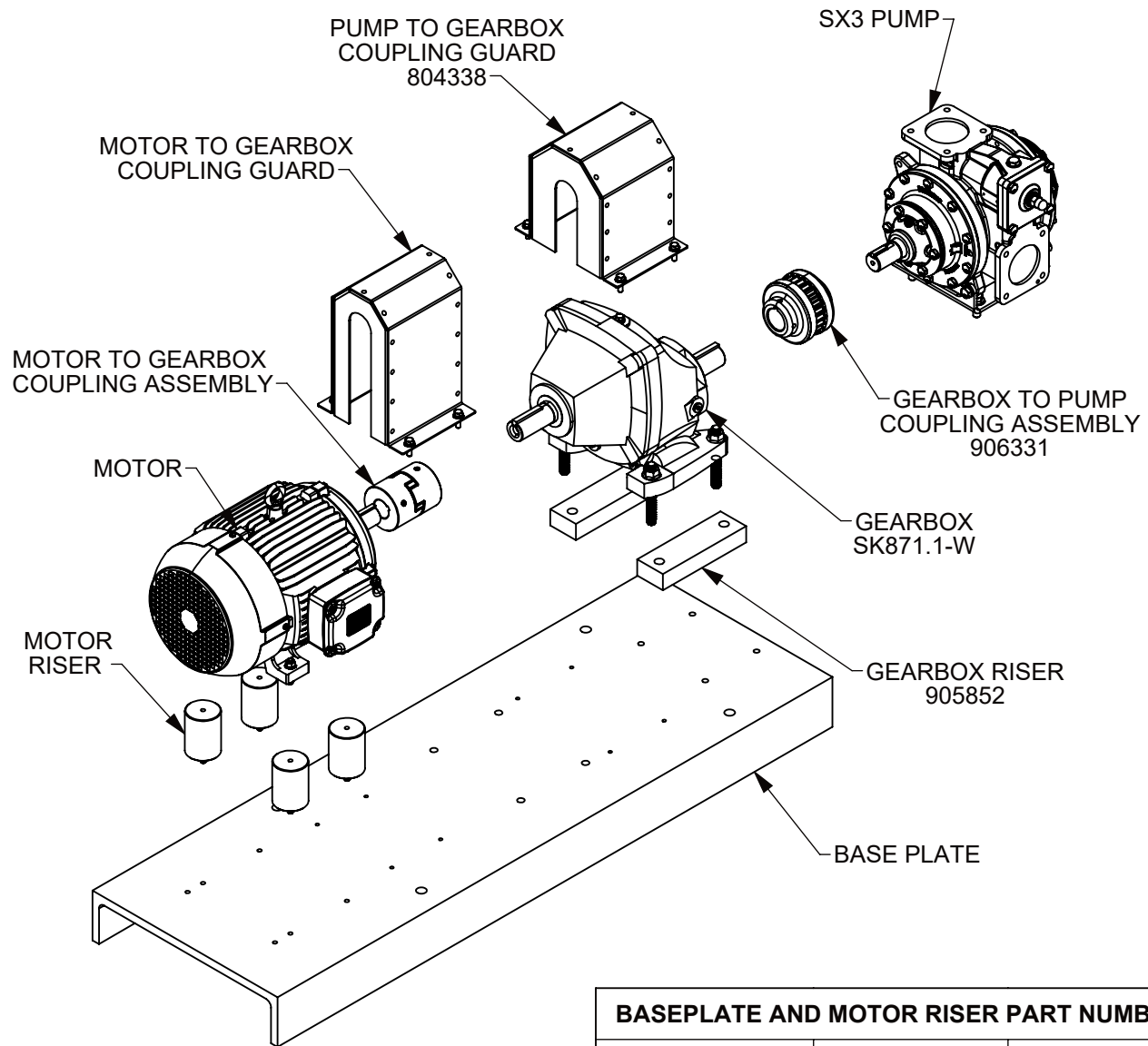

BASEPLATE AND MOTOR RISER PART NUMBERS		
MOTOR FRAME	BASEPLATE	MOTOR RISER
213T/215T	901423	905854
254T/256T	901427	905855
284T/286T	901430	905853
COUPLING AND GUARD PART NUMBER		
MOTOR FRAME	MOTOR TO GEARBOX COUPLING ASSY	MOTOR TO GEARBOX COUPLING GUARD
213T/215T	906314	804323
254T/256T	906319	804323
284T/286T	906320	804332

NORD SK871.1-W GEARBOX PART NUMBERS		
RATIO	SPEEDS 60Hz/50Hz	PART NUMBER
2.50:1	NA / 580 RPM	803116
3.42:1	512 RPM / 424 RPM	803117
3.89:1	450 RPM / 373 RPM	803118
4.29:1	408 RPM / 338 RPM	803119
5.27:1	332 RPM / 275 RPM	803120
7.17:1	244 RPM / 202 RPM	803121