

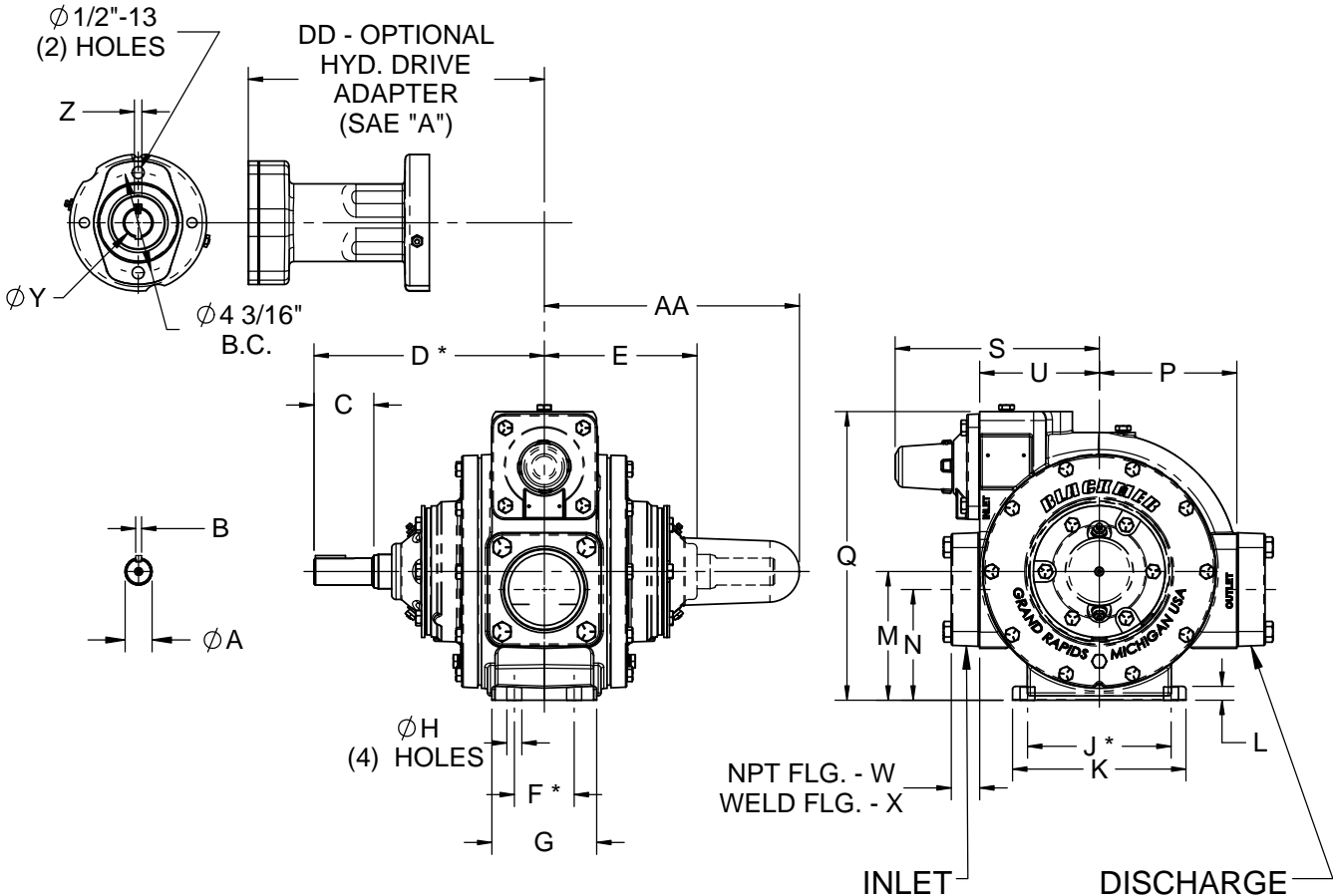

TYPE	UNIT	DIMENSIONS 201-137	
	STYLE	Section Effective Replaces Page 1 / 1	201 MAY2016 NEW
TXDI3A INLINE	PO		

RIGHT HAND ROTATION. FOR LEFT HAD ROTATION, SHAFT PROJECTION IS OPPOSITE THAT SHOWN.
 * TOLERANCE $\pm 1/8"$
 TOLERANCE ON OTHER DIMENSIONS $\pm 1/4"$



DIMENSIONS											WEIGHTS	
UNITS	A	B	C	D	E	F	G	H	J	K	UNITS	PUMP ONLY
IN	1 1/8	1/4	2 1/2	9 5/8	6 3/8	2 1/2	4 3/8	5/8	6	7 1/4	LBS	139
MM	---	---	63,5	244,5	161,9	63,5	111,1	15,9	152,4	184,2	KG	63
	L	M	N	P	Q	R	S	T	U	V		W/ NPT FLANGES
IN	1/2	5 3/8	4 5/8	5 3/4	12 1/16	---	8 9/16	---	5	---	LBS	147
MM	12,7	136,6	117,5	146,1	306,4	---	217,5	---	127	---	KG	67
	W	X	Y	Z	AA	BB	CC	DD	EE	FF		W/ WELD FLANGES
IN	1 1/8	1 3/16	1 1/4	5/16	10 11/16	---	---	12 3/8	---	---	LBS	146
MM	28,6	30,2	31,8	7,9	21,5	---	---	314,3	---	---	KG	66
	GG	HH	JJ	KK	LL	MM						:
IN	---	---	---	---	---	---					LBS	
MM	---	---	---	---	---	---					KG	