



www.blackmer.com

TYPE	SIZE	UNIT STYLE
NP	2F	PO

DIMENSIONS 103-105

Section	103
Effective	Sept 2023
Replaces	Nov 2001
Page	1/4

RIGHT HAND ROTATION. FOR LEFT HAND ROTATION, SHAFT PROJECTION IS OPPOSITE THAT SHOWN.

* TOLERANCE $\pm \frac{1}{8}$
TOLERANCE ON OTHER DIMENSIONS $\pm \frac{1}{4}$

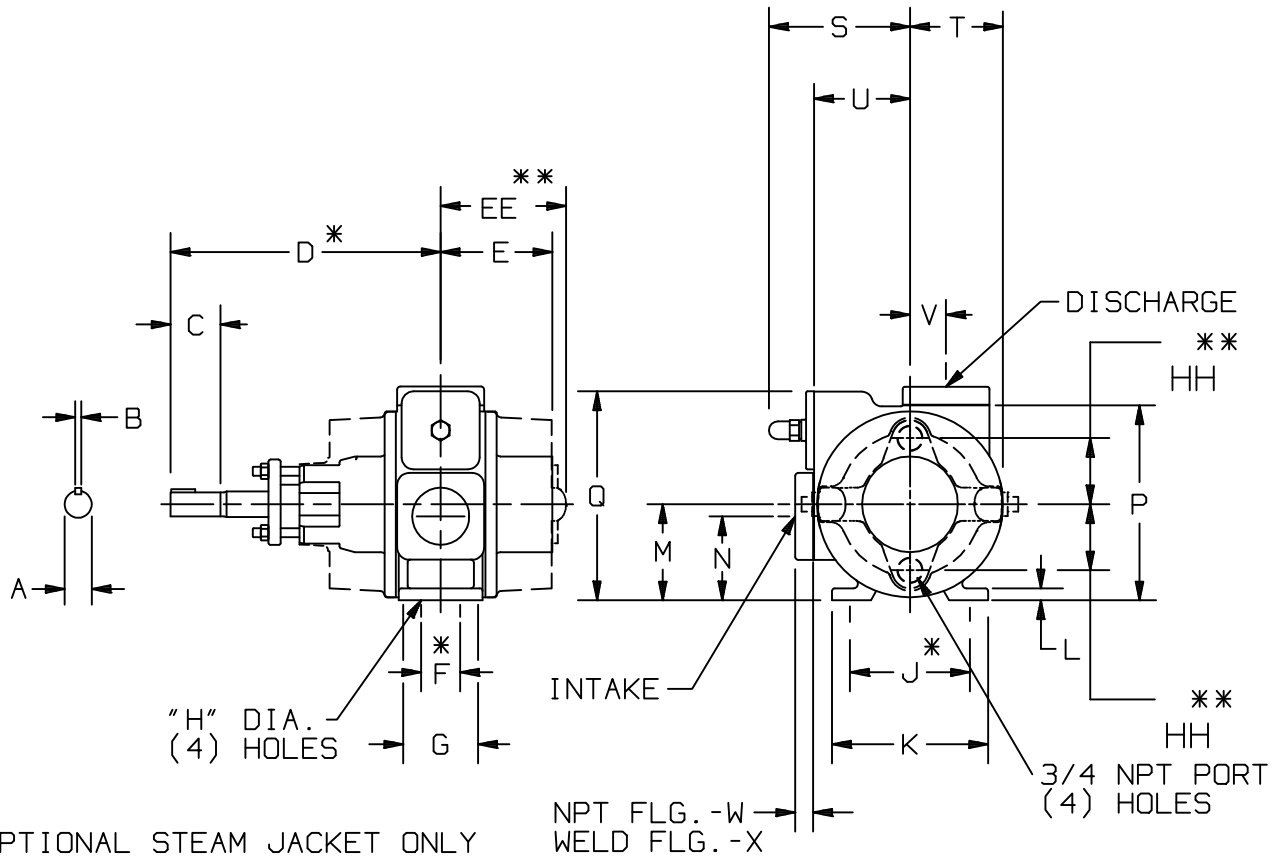

** OPTIONAL STEAM JACKET ONLY

MOTOR			UNITS	DIMENSIONS									
FRAME SIZE				A	B	C	D	E	F	G	H	J	K
			IN	1	1/4	2 1/16	11 1/4	4 7/8	1 5/8	3 1/2	7/16	5	6 1/2
			MM	25,4	6,4	52,4	285,8	123,8	41,3	88,9	11,1	127	165,1
				L	M	N	P	Q	R	S	T	U	V
			IN	1/2	4	3 1/2	8 1/8	8 11/16	—	5 7/8	3 7/8	4	1 1/2
			MM	12,7	101,6	88,9	206,4	220,6	—	149,2	98,4	101,6	38,1
				W	X	Y	Z	AA	BB	CC	DD	EE	FF
			IN	13/16	1 1/4	—	—	—	—	—	13 1/8	5 1/4	—
			MM	20,6	31,8	—	—	—	—	—	333,4	133,4	—
				GG	HH					PUMP WEIGHT	WITH STD. FLANGES	** WITH JACKETED HEADS	
			IN	—	2 3/4					LBS	65	77	
			MM	—	69,8					KG	30	34,9	

NOTE: FOR ANSI AND DIN FLANGE DIMENSIONS, SEE DIMENSION SHEET 103-115

TYPE	SIZE	UNIT STYLE
NP	2	HRA

DIMENSIONS 103-105	
Section	103
Effective	Sept 2023
Replaces	Nov 2001
Page	3/4

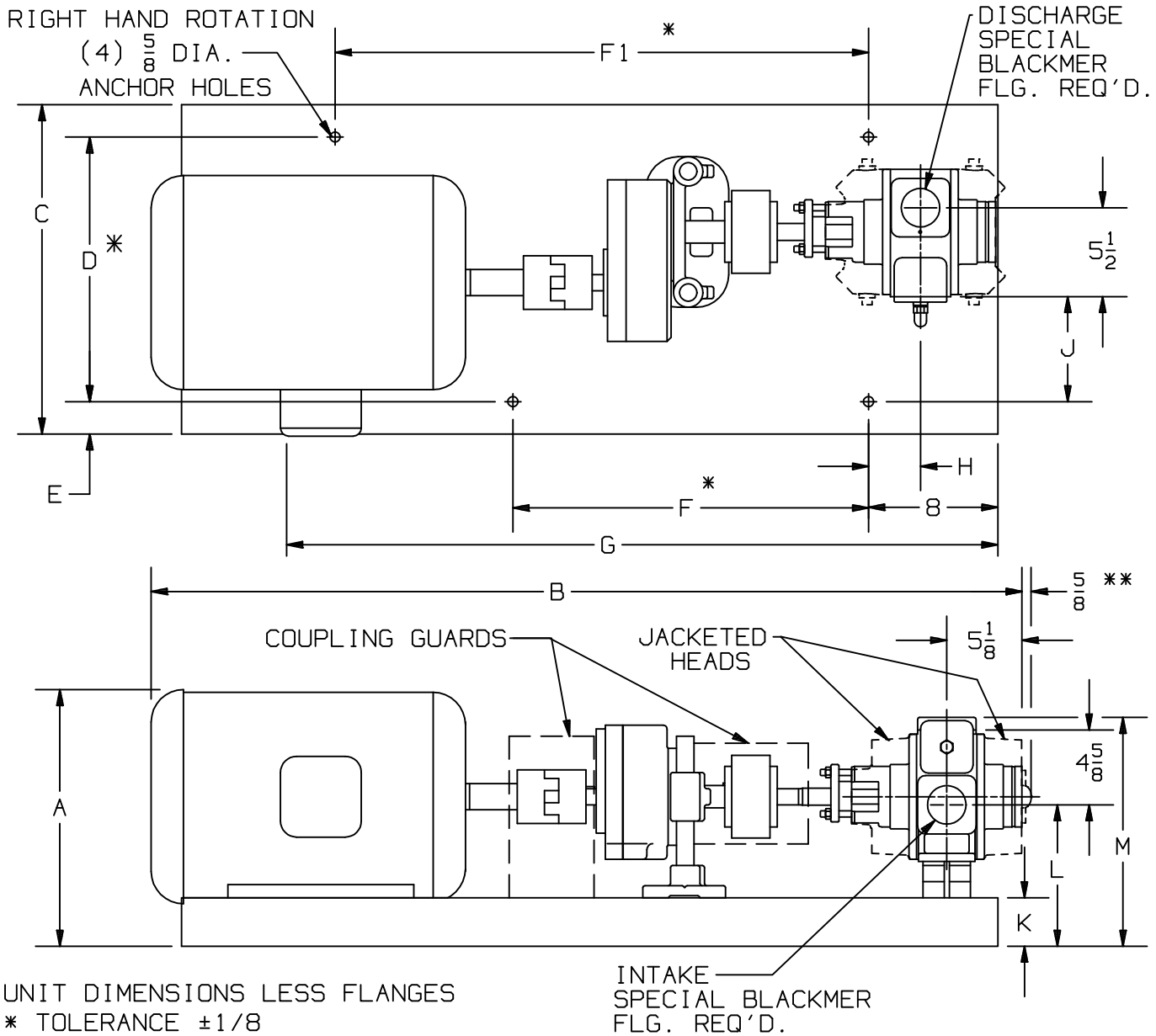

UNIT DIMENSIONS LESS FLANGES
 * TOLERANCE $\pm 1/8$
 TOLERANCE ON OTHER DIMENSIONS $\pm 1/4$
 "A" DIMENSION LESS EYEBOLT
 ** FOR JACKETED HEADS

FLG. HT: 2" NPT 13/16
 2" WELD 1-1/4

FRAME SIZE	BASE NO.	DIMENSIONS														
		A	B	C	D	E	F	F ₁	G	H	J	K	L	M		
182T	901795	12 7/8	46	17 1/4	14	1 5/8	15	26	44	4 1/8	5 3/8	2 1/4	6 3/4	12 3/8		
184T	901795	12 7/8	46 3/4	17 1/4	14	1 5/8	15	26	44	4 1/8	5 3/8	2 1/4	6 3/4	12 3/8		
213T	901794	14 1/8	51 5/8	20 3/8	16 3/8	2	22	33	50 1/2	3 1/4	6 1/2	3	7 1/2	13 1/8		
215T	901794	14 1/8	51 5/8	20 3/8	16 3/8	2	22	33	50 1/2	3 1/4	6 1/2	3	7 1/2	13 1/8		
254T	901794	16 3/8	53 1/2	20 3/8	16 3/8	2	22	33	50 1/2	3 1/4	6 1/2	3	7 1/2	13 1/8		
256T	901794	16 3/8	55 1/4	20 3/8	16 3/8	2	22	33	50 1/2	3 1/4	6 1/2	3	7 1/2	13 1/8		

DIMENSIONS 103-105

Section 103
 Effective Sept 2023
 Replaces Nov 2001
 Page 4/4

TYPE	SIZE	UNIT STYLE
NP	2	HRA

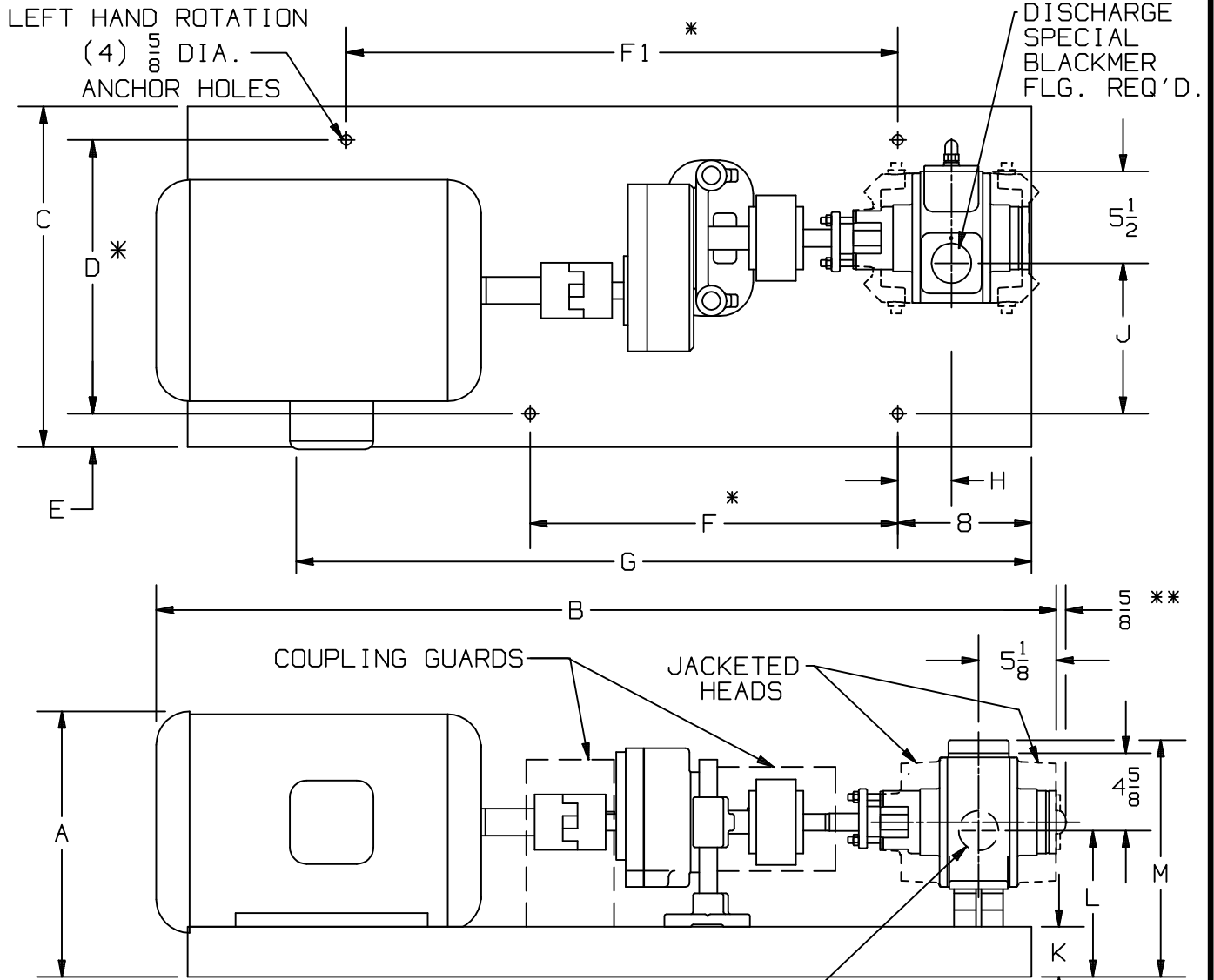

UNIT DIMENSIONS LESS FLANGES

* TOLERANCE ±1/8

TOLERANCE ON OTHER DIMENSIONS ±1/4

"A" DIMENSION LESS EYEBOLT

** FOR JACKETED HEADS

FLG. HT: 2" NPT 13/16
 2" WELD 1-1/4

FRAME SIZE	BASE NO.	DIMENSIONS														
		A	B	C	D	E	F	F ₁	G	H	J	K	L	M		
182T	901795	12 7/8	46	17 1/4	14	1 5/8	15	26	44	4 1/8	7 7/8	2 1/4	6 3/4	12 3/8		
184T	901795	12 7/8	46 3/4	17 1/4	14	1 5/8	15	26	44	4 1/8	7 7/8	2 1/4	6 3/4	12 3/8		
213T	901794	14 1/8	51 5/8	20 3/8	16 3/8	2	22	33	50 1/2	3 1/4	9	3	7 1/2	13 1/8		
215T	901794	14 1/8	51 5/8	20 3/8	16 3/8	2	22	33	50 1/2	3 1/4	9	3	7 1/2	13 1/8		
254T	901794	16 3/8	53 1/2	20 3/8	16 3/8	2	22	33	50 1/2	3 1/4	9	3	7 1/2	13 1/8		
256T	901794	16 3/8	55 1/4	20 3/8	16 3/8	2	22	33	50 1/2	3 1/4	9	3	7 1/2	13 1/8		