

COMPRESSOR MOUNTING ARRANGEMENTS

Blackmer compressors are available from the factory as bare units or in a variety of mounting arrangements. These mountings share standard Blackmer quality features such as heavy gauge steel beltguard with side brace, liquid filled stainless steel pressure gauges, and two part epoxy paint. Most are built from supplies in stock, thus not effecting delivery time. Motors, motor starters, engines, relief valves, aftercoolers, shutdown switches, control panels, special baseplates, etc. can be added to tailor a compressor to a particular user's needs.

Any of the mounting styles may be used with Single-stage units. Two-stage units are typically supplied with B, TU, TC and TW mountings. The ELU and ETU mountings are for transport mounted 160/360 sizes – the compressor is often fitted with an extended crankshaft for PTO drive.

B MOUNTING

Base mounted, V-belt drive unit with:

- Suction & discharge pressure gauges:
Liquid filled, Stainless Steel
(single-stage units only)
- Formed steel baseplate
- Static conducting V-belt drive
- Heavy gauge steel belt guard with brace
- Adjustable motor base

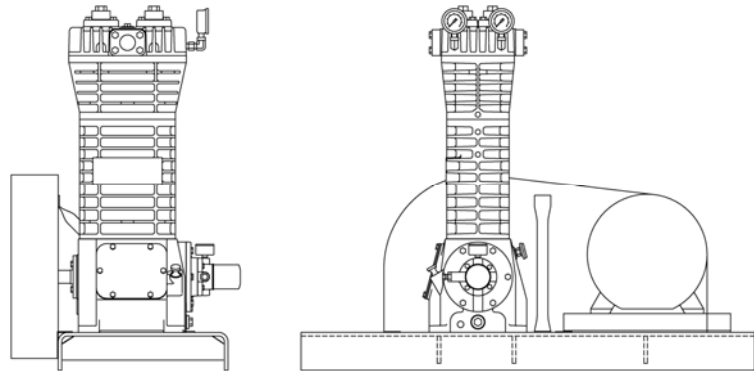

LU & ELU MOUNTINGS

The LU mounting is the standard for liquefied gas transfer service as it is designed to perform both liquid transfer and vapor recovery operations simply by reversing the 4-way valve's position. It includes the following items:

- B mounting as described above
- Inlet liquid trap with internal mechanical float and manual drain
- Four way control valve
- Interconnecting piping
- Strainer with 30 mesh SS screen
- Optional liquid level switch

The ELU mounting is specially designed for transport use. These mountings feature a smaller, stiffer baseplate and do not have a motor slide base or beltguard.

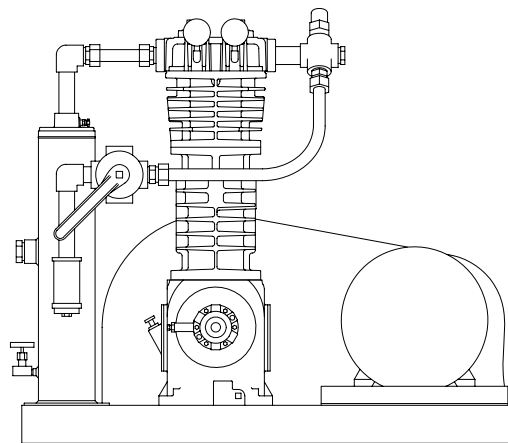

AE92-99022-1

LC and LW MOUNTINGS

Similar to the LU style but with a larger ASME code liquid trap, the LC/LW mounting is used when ASME code construction is desired or where liquid is expected to be present in the suction line on a regular basis. The LC/LW arrangement includes:

- B mounting as described above
- ASME code 12" dia. liquid trap with internal stainless steel mist pad, relief valve, liquid level switch (NEMA 7), manual drain valve. Capacity is 10 gallons at the level switch.
- Second liquid level switch available
- Four way control valve
- Strainer with 30 mesh SS screen (LC only)
- NPT Interconnecting piping (LC)
- Welded & Flanged Interconnecting piping (LW)
- Structural Steel Baseplate (std. on LW)

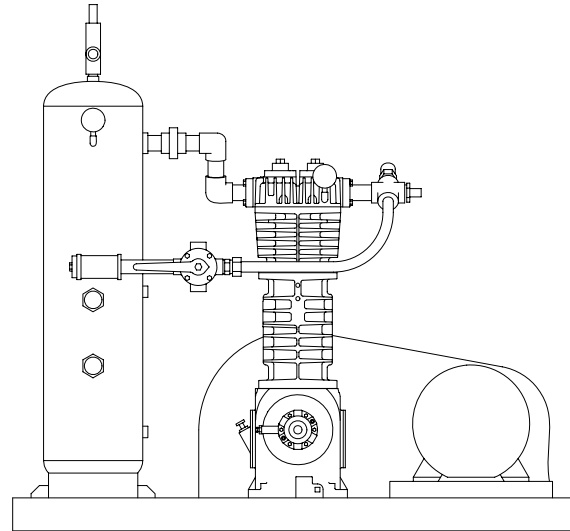

TU & ETU MOUNTINGS

The TU arrangement is typically used for liquefied gas transfer or vapor recovery and is recommended anytime liquid may be present in the suction piping. It includes:

- B mounting as described above
- Inlet liquid trap with mechanical float and manual drain
- Interconnecting piping
- Optional liquid level switch

The ETU mounting is specially designed for transport use. These mountings feature a smaller, stiffer baseplate and do not have a motor slide base or beltguard.

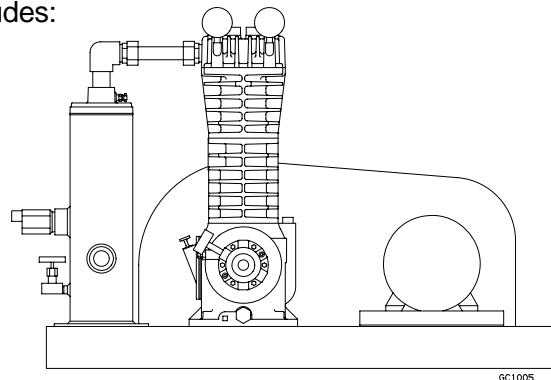

TC and TW MOUNTINGS

The TC/TW is similar to the TU style but with a larger ASME code liquid trap. This mounting is used where ASME code construction is desired or where liquid is expected to be present in the suction line on a regular basis. It includes:

- B mounting as described above
- ASME code 12" dia. liquid trap with internal stainless steel mist pad, relief valve, liquid level switch (NEMA 7), manual drain valve. Capacity is 10 gallons at the level switch.
- Second liquid level switch available
- NPT Interconnecting piping (TC)
- Welded & Flanged Interconnecting piping (TW)
- Structural Steel Baseplate (std. on TW)

