



LGLH2 High Pressure LPG Pump

Based on Blackmer's industry standard LGLD2 transfer pump, the LGLH2 has the muscle to handle the toughest jobs. Whether pumping from a bobtail to the top of an 8-story building or feeding a vaporizer in the middle of winter – the LGLH2 can do it.

Applications

- High differential pressure bobtail delivery trucks
- High capacity LPG fueling
- Aerosol filling
- Vaporizer feed
- Other high differential pressure liquefied gas applications
- U.L. listed for use on propane, butane, and propane/butane mixes

Features

- Designed for high differential pressure of 165 psi (11.4 bar)
- Sliding vane, positive displacement design for consistent performance
- Dimensionally interchangeable with the LGLD2
- Up to 980 rpm operation
- Cavitation suppression liner
- Replaceable liner and discs
- Ductile iron construction
- Flanged inlet and outlet connections
- Factory ISO-9001 certified

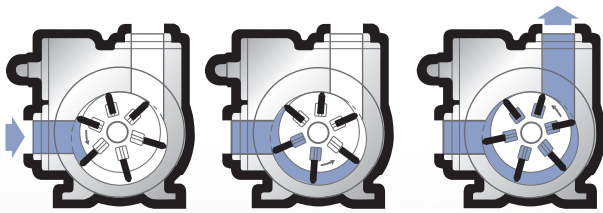
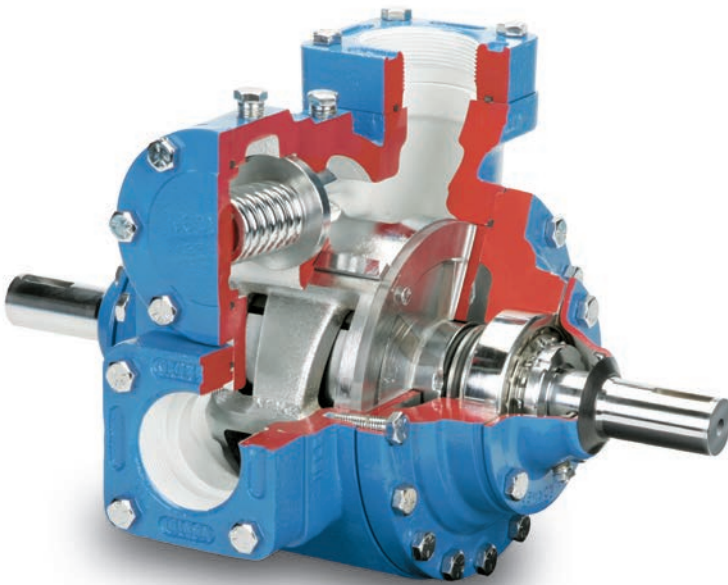

How Blackmer's sliding vane action works





LGLH2 High Pressure LPG Pump

Performance

Performance at 145 psid (10 bar) Differential Pressure			Maximum Differential Pressure	Relief Valve Setting	Maximum Working Pressure
780 rpm	640 rpm	520 rpm			
61 gpm / 11.7 hp	47 gpm / 9.2 hp	32.6 gpm / 7.1 hp	165 psi	190 psi	390 psi
231 L/min / 8.7 kW	178 L/min / 6.9 kW	123 L/min / 5.3 kW	11.4 bar	13.1 bar	26.9 bar

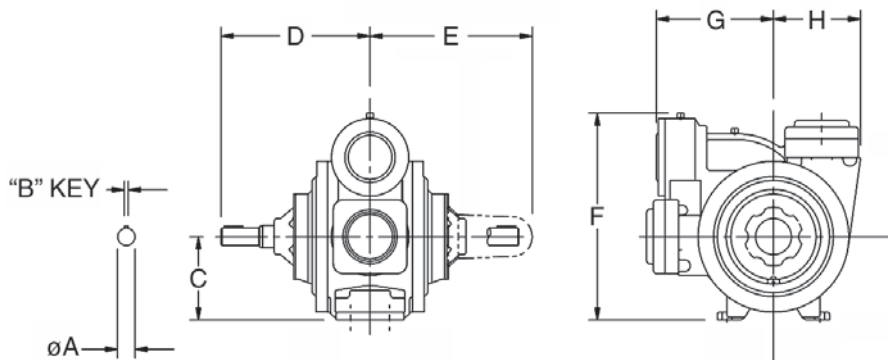

Dimensions

A	B	C	D	E	F	G	H	Weight
1 1/8 in.	1/4 in.	4 in.	8 in.	8 15/16 in.	10 in.	5 1/2 in.	4 3/16 in.	85 lb.
-	-	101.6 mm	203.2 mm	227 mm	254 mm	139.7 mm	106.4 mm	39 kg

BV Bypass Valves

U.L. listed BV1.25" and BV1.5" bypass valves with 165 psi (11.4 bar) setting are available for use with the LGLH2.

VB Drive Style

V-Belt Drive

Standard base-mounted VB units are available, complete with pump, hubs, sheaves, high-torque V-belts and belt guard, mounted on a common base, ready to accept a standard NEMA motor. All VB units are available with or without motors.

HR Drive Style

Helical Gear Reduction Drive

Standard base-mounted HR units are available, complete with pump, Blackmer Helical Gear Reducer, mounting brackets, couplings and coupling guards, mounted on a common base, ready to accept a standard NEMA motor. All HR units are available with or without motors.



Process | Energy | Military & Marine
PSG Grand Rapids

1809 Century Avenue SW, Grand Rapids, MI 49503-1530 USA

T 616.241.1611 • F 616.241.3752

blackmer.com



Authorized PSG® Partner: