

Operating and Installation Instructions

FUTUR Series



FUTUR T



FUTUR E



FUTUR H



FUTUR S/SH

ought to be studied before installing the pump

Original Instruction



INHALTSVERZEICHNIS	Seite
Introduction	3
General description of the machine, appropriate use and residual dangers	3
Storage and long-term usage	3
Technical data	4
Performance charts	5
Commissioning	7
Operation in explosion-proof areas and for inflammable liquids	8
Special operating conditions	8
Installation into the piping	10
Connection of the suction and discharge line	10
Connection of the air supply	10
Start-up and operation of the pump	11
Safety hints	11
Additional temperature hints	13
Disassembly	14
Assembly	15
Troubleshooting	16
Dimensions	18
Spare parts FUTUR T / H / E	19
Exploded view FUTUR T / H / E	20
Spare parts FUTUR S / SH	21
Exploded view FUTUR S / SH	22
Special equipment	
Pneumatic stroke counting	23
Diaphragm sensor	23
Flaretek®-connectors	23
VCR-connectors	23
Spare part list special equipment	24
Pulsation damper D series	24
Safety hints	24
Installation and operation	25
Disassembly and assembly	25
Technical data	26
Spare part list	26
Exploded view	27

Introduction

ALMATEC air-operated diaphragm pumps are constructed according to the state of the art and they are reliable. Imminent danger by operating error or misuse can lead to damages of properties and/or persons. The pumps are to be applied for the intended use and in a safety-related proper condition only.

Each person working on the ALMATEC air-operated diaphragm pumps concerning installation, start-up, handling or maintenance has to read this manual completely and in an attentive way and has to follow all mentioned procedures and safety notes.

General description of the machine, appropriate use and residual dangers

The ALMATEC FUTUR pumps are oscillating positive displacement pumps and are based on the functional principle of double diaphragm pumps. The basic configuration consists of two external side housings with a centre housing between them. The liquid flows straight through the product chambers of the centre housing, while the air control system and the air chambers are located in the side housing. This design ensures that only one part of the housing comes in contact with the liquid: the centre housing. The product chambers on both sides of the centre housing are limited to the side housings by a diaphragm. Controlled by an air control system the diaphragms move back and forth and the liquid in the product chambers will be sucked in or displaced.

The appropriate use of an Almatec air-operated diaphragm pump refers to the liquid transport taking into account the operation parameter mentioned in this manual and in compliance of the given terms for commissioning, operation, assembly, disassembly and maintenance.

Even if all necessary safety measures described in this manual have been met, a residual danger exists by leakages or mechanical damages. At sealing areas or connections liquid can be released uncontrollably then.

Storage and long-term usage

In general, the ALMATEC pump is delivered operational and packaged. If the unit is not installed right away, proper storage conditions are important for a trouble free operation later. The pump has to be protected from wetness, coldness, dirtying, UV-radiation and mechanical influences. The following storage conditions are recommended:

- Steady ventilated, dust and vibration free storage room
- Ambient temperature between 15°C and 25°C with a relative humidity below 65%
- Prevention of direct thermal influences (sun, heating)

Plastic materials are subject to aging processes depending on material, surrounding conditions and application parameters. Chemical contact and/or increased temperature can amend material characteristics on the long run, especially mechanical capabilities.

For safety reasons, we do therefore recommend as part of every maintenance (resp. in case of no maintenance till then after two years and then every six month): A careful visual check of all pump parts for visible damages, a tactile check of all sealing surface (e.g. by moving a finger along the surface after cleaning), a shape-check of the housing parts (e.g. by laying a drawer on plain surfaces) and a movability check of all threads. Any eventually damaged part needs to be replaced!

Technical Data

Pump size	10	20	50	100
Dimensions (mm),	please see page 18			
Nominal port size (NPT)	3/8"	1/2"	1"	1 1/4"
Air connection (NPT)	1/4"	1/4"	1/4"	1/4"
Drive air quality classes according to ISO-DIS 8573-1:				
Solid's content, class:	2	2	2	2
Water content, class:	3	3	3	3
Oil content, class	3	3	3	3
Weight (kg),				
FUTUR T	2,3	4,2	8,8	17,6
FUTUR H	2,6	5,0	11,2	-
FUTUR E	-	2,8	5,8	-
FUTUR S	-			-
FUTUR SH	-			-
Suction head, dry (mWC)	1	2,5	3,5	4
Suction head, with product (mWC)	8	9	9	9
Max. permissible driving pressure (bar)	6	6	6	6
Max. sound pressure level acc. to DIN 45635, part 24, at maximum load [dB(A)]	72	72	72	72

Max. permitted operating in °C					
Pump model	FUTUR H	FUTUR T	FUTUR E	FUTUR S	FUTUR SH
at max. 6 bar	100	100	70	80	130
at max. 5 bar	130	110	70	80	130
at max. 4 bar	150	120	70	80	130
at max. 3 bar	180	130	70	80	130
at max. 2 bar	200	130	70	80	130

Performance charts

The data refer to water (20°C), without using of a pulsation damper. The specified performance data are warranted by ALMATEC in accordance with DIN EN ISO 9906 (vertical lines show the air consumption).

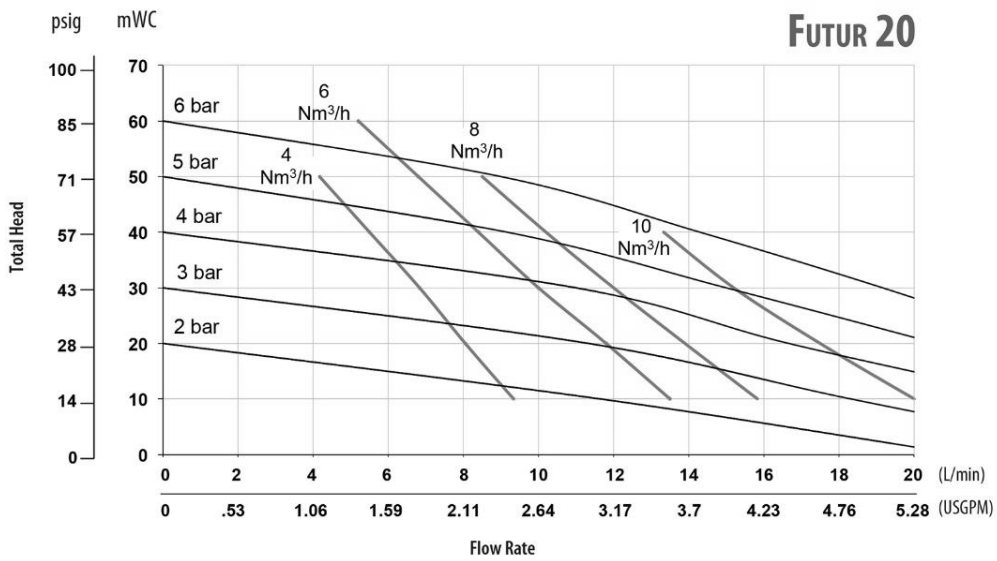
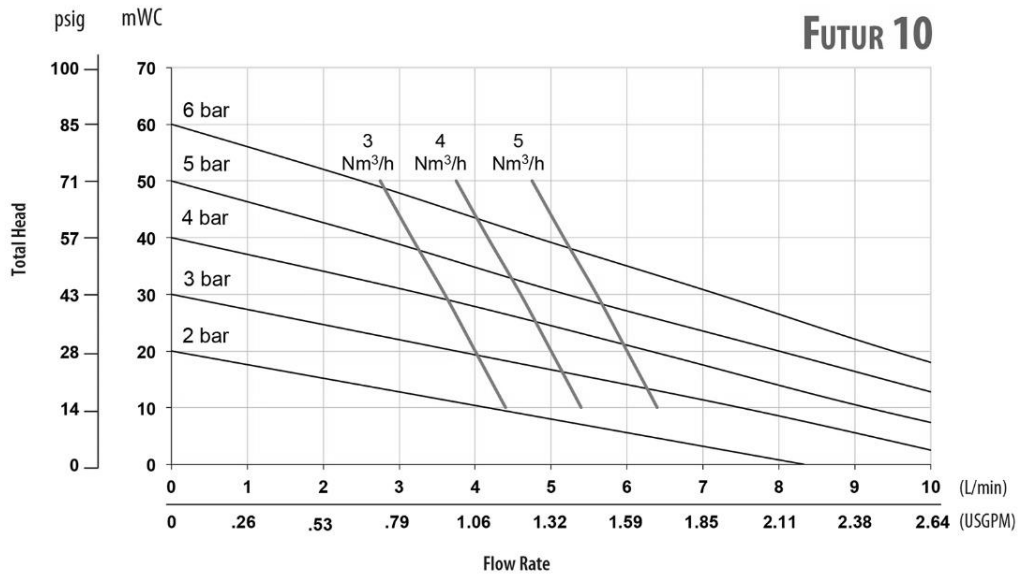

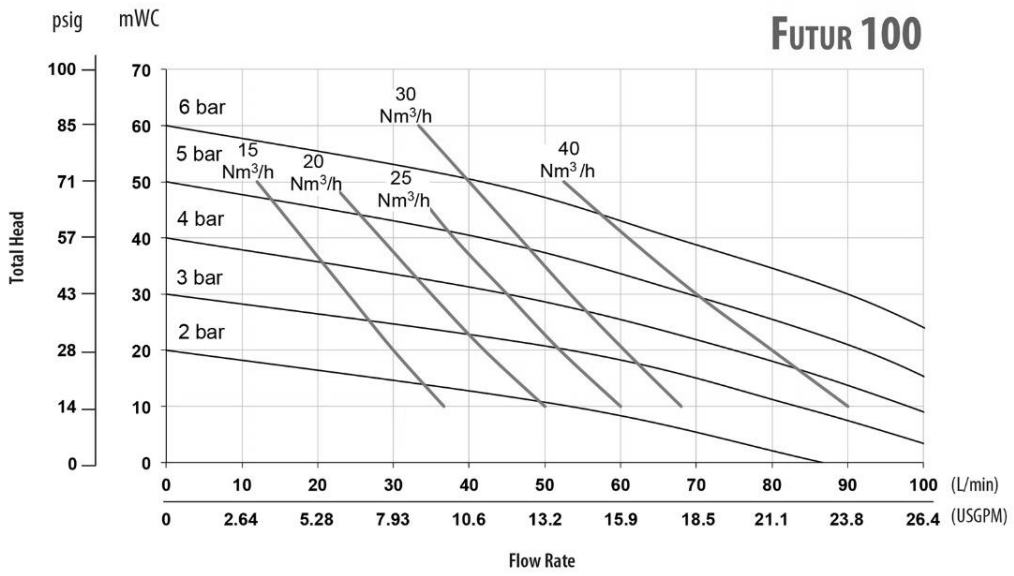
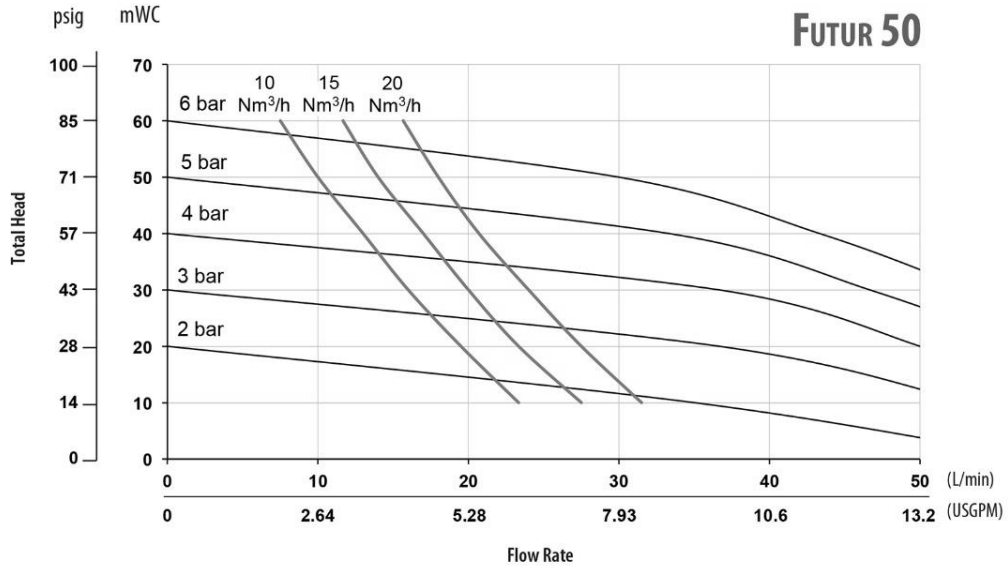

Commissioning

PSG Germany GmbH is certified as a modern, quality-orientated enterprise acc. to DIN EN ISO 9001 and 14001. Before release for dispatch, any FUTUR pump has to undergo an extended final control. The performance data registered during this are archived in our records and can be read back at any time.

Every individual part mentioned in the following text is identified by a number in square brackets corresponding with its item number in both the spare part list and the exploded view.

The series FUTUR has specially been developed to meet the requirements of the semiconductor industry. These pneumatic diaphragm pumps differ from other available pneumatic pump types significantly. All pumps are assembled in a clean room with twofold preliminary cleaning of the individual parts and testing with de-ionised water. Afterwards, they are doubly sealed into plastic foils so that they can directly be taken into clean rooms within the intact inner sleeve.

Because of the significant differences, a diligent study of this Operating and Installation Instructions before putting into operation is necessary even for users experienced in applying pneumatic diaphragm pumps. Special tools or devices are not required. A multi-functional mounting tool [36] is enclosed with every pump.

You can as well send your FUTUR pump to our facilities in Duisburg, Germany, if your workshop is not equipped accordingly or if you wish to avoid contamination during repairs which would subsequently give rise to extensive rinsing processes when reused in the plant. The required service is carried out promptly and under strict purity conditions.

As a general rule in the countries of the EU only such machines are allowed to take into operation, which are determined to meet the regulations of the EU machinery directive, the harmonized standards, European standards and the respective national standards. Hence the operator has to verify whether the ALMATEC pump manufactured and delivered properly according to the customers order meets the mentioned requirements.

All wetted parts of the FUTUR T and FUTUR H consist of PTFE, the wetted housing parts of the FUTUR E are made of UPPE (ultra pure polyethylene) and of the FUTUR S/SH of SS316L. Before putting any pump into operation, make sure, that the materials of construction are resistant to the liquid to be pumped.

When handling aggressive fluids with increased purity demands, we recommend to condition the pump via circulating the dedicated fluid prior to any start up (as well after maintenance) to avoid contamination by eventual residuals in the system and/or the pump from handling, testing etc.

The maximum operating pressure is limited to 6 bar and the allowed maximum temperature of the liquid can be taken from the technical data on page 4. For the FUTUR H and FUTUR T the maximum permissible limits for driving pressure and temperature of the medium are mutually dependent.

Operation in explosion-proof areas and for inflammable liquids

X = CAUTION! = Special operating conditions apply!

The FUTUR models S and SH are conformed to the ATEX regulations and therefore can be used for inflammable liquids as well as for applications in explosion-proof areas. The pumps have to be grounded to the corresponding connection on the backside of the center housing. The ground connection must have a minimum cross-section of 6 mm². All other housing parts are connected to the pump housing, so it is not necessary to ground single parts.

ALMATEC air-operated diaphragm pumps made of electrically conductive material are suitable for use in potentially explosive atmospheres of category 2 and 3 ("Zone 1" and "Zone 2" respectively), atmosphere G/D, which are subject to the scope of EU Directive 2014/34/EU. Using non-conductive diaphragm material (material code 69) Explosion group IIB applies without restriction to size FUTUR 20 S. For the size FUTUR 50 S, the following protective measures must be taken as an example:

- exclusive use of water-miscible or conductive pump media or
- Avoidance of dry running through operational measures or
- inerting during dry running with nitrogen, water, carbon dioxide, etc. following the pumping operation.

Pipelines and product connections must be grounded separately. To avoid ignition hazards, the formation of dust deposits on the units must be prevented. Repairs in hazardous areas may only be carried out after careful examination of the feasibility and only with appropriate tools and by trained specialist personnel.

The ATEX marking according to Directive 2014/34/EU can be found in the enclosed Declaration of Conformity and the corresponding sticker on the pump or damper.

The interfaces for electrical accessories have been considered and do not represent a new potential ignition source.

The type of protection "**c = design safety**" was applied in accordance with guideline EN ISO 80079-37.

SPECIAL OPERATING CONDITIONS	FUTUR 20 S / D 20 S	FUTUR 50 S / D 50 S
Permissible ambient temperature (°C)	-10 - 50	
Permissible temperature of compressed driving air (°C)	0 - 50	
Maximum driving/operating pressure (bar)	6	
Maximum operating temperature (X):		
Code S (°C):	80	
Code SH (°C):	130	

The ATEX marking for gases and dusts is defined as follows according to 2014/34/EU:

In order to enable the optimum and flexible design of an ATEX pump to the customer-specific application, a differentiation is made in the marking between the installation location of the pump (hazardous area outside the pump) and the inside of the pump (hazardous area inside the pump).

Equipment category G (gases, mists, vapors)

Installation site: Category G

Inside the pump: Category G

Conductive ALMATEC air-operated diaphragm pumps may generally be used in explosion group IIC at the installation site (potentially explosive area outside the pump), since the solid housings are made of dissipative materials and the entire pump is grounded.

ATTENTION! Inside the pump, the permitted explosion group varies depending on the diaphragm material used:

When using **non-conductive diaphragms**, explosion group IIB applies inside the pump:

⊕ II 2/2 G Ex h IIB/IIC T6...T4 Gb/Gb X (inside the pump/installation site)

When using **conductive diaphragms**, explosion group IIC applies inside the pump:

⊕ II 2/2 G Ex h IIC/IIC T6...T4 Gb/Gb X (inside the pump/installation site)

Equipment category D (dusts)

Installation site: Category D

Inside the pump: Category G

Conductive ALMATEC air-operated diaphragm pumps may generally be used in dust group IIIC at the installation site (potentially explosive area outside the pump; equipment category D).

ATTENTION! Inside the pump (equipment category G), the approved explosion group varies depending on the diaphragm material used:

When using **non-conductive diaphragms**, explosion group IIB applies inside the pump:

⊕ II 2/2 D Ex h IIB/IIIC T 70°C...130°C Gb/Db X (inside the pump/installation site)

When using **conductive diaphragms**, explosion group IIC applies inside the pump:

⊕ II 2/2 D Ex h IIC/IIIC T 70°C...130°C Gb/Db X (inside the pump/installation site)

Installation into the piping

UV-radiation can damage the housing parts of pumps made of PE. Pumps must be connected load free without any tension. They cannot serve as a fixed point for the piping. Neglecting this causes leakage and maybe even damages. In case movements or vibrations have to be expected, we recommend the installation of compensators upstream and downstream of the pump. The FUTUR can be used standing free or can be installed using the anchor bolt bushings [27]. The operator is responsible for an adequately stability and an appropriate fixation of the piping according to the state of the art. To facilitate the installation and maintenance shut off valves should be installed right before and after the pump.

Connection of the suction and discharge line

The nominal width of the connection pipes has to be chosen in accordance to the connections of the pump:

Pump size	10	20	50	100
Nominal port size (NPT)	3/8"	1/2"	1"	1 1/4"

A smaller piping can cause cavitation (suction line) as well as a loss of performance (suction and discharge line). In case the pipe is too big, the dry suction capacity of the pump can decrease. The suction line must be connected to the lower port of the center housing [1] and the discharge line to the upper port. A suction line with a steady upward gradient prevents the formation of air bubbles in the line obstructing the suction performance. As option the pumps can be equipped with Flaretek® connectors for PFA-pipe (special equipment code G) and VCR connectors for FUTUR S/SH (code V).

Connection of the air supply

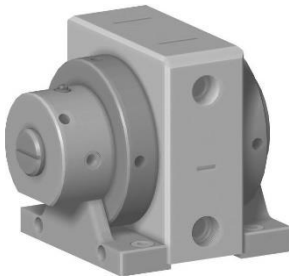

The bore to connect the compressed air is located in the left hand side housing [16] opposite to the muffler [20]. An appropriate cross-section of the air supply line must be ensured to supply the pump with driving air sufficiently. The line must be at least equal to the nominal width of the connection of the pump (R 1/4). The integrated air control system PERSWING P® is a precision-steering that requires oil-free, dry and clean compressed air for optimal function. The following minimum requirements of the air quality classes according to ISO-DIS 8573-1 must be met:

Solids content	<input type="checkbox"/>	Class 2
Water content	<input type="checkbox"/>	Class 3
Oil content	<input type="checkbox"/>	Class 3

In humid surroundings, icing from the outside may occur despite the driving air is dried. If so, a prolonged waste-air-exhaust (ca. 500 mm by pipe or hose) can be helpful. When installing the pump into boards or cabinets, it has to be ensured that cold air does not get caught behind the muffler. In applications with a tendency to freezing at the waste air exhaust, good experiences in practise have been achieved by pre-heating the driving air to increase the distance to the dew point of the air. Doing so, it has to be considered that the driving air temperature generally may not exceed 50°C to avoid expansion and sticking effects on the air side.

Start-up and operation of the pump

The pump is ready to be operated after the connection of all lines. The pressure of the driving air should be limited to the amount required to meet the performance needed. Excessive pressure increases both the air consumption and the wear of the pump. However, the air-pressure should not be lower than 1,5 bar to ensure a steady and reliable flow. The pump is regulated by tuning the flow rate of the air (needle valve). An empty pump has to be driven slowly. In general, dry running at high frequency or for an extended period of time has to be avoided for air-operated double diaphragm pumps with a centred flow pattern. Any disregard may result in damaging the pump functionally. The pump starts operating automatically when air is supplied. As FUTUR pumps are self-priming, it is not necessary to pre-fill the suction line and the pump itself. The suction capacity of a filled pump is much bigger, however; any throttling on the suction side can damage the pump. Short-term operation against a closed discharge for pressure testing is possible. In case special ways of operation (e.g. closed discharge) are necessary, this has to be tuned with the manufacturer. The max. stroke frequencies listed in the table below may not be exceeded during normal every-day operation. Otherwise, premature wear has to be expected.

Pump size	10	20	50	100
Max. number of strokes/min. at nominal performance	400	320	210	240

Safety hints



- Installation, operation, and maintenance by qualified staff only.
- Before start-up respectively after the first hours of operation, the union nuts [22] must be checked for tightness; if necessary they have to be tightened. This may also be necessary after longer periods of stoppage, with large variations of temperature, transport as well as disassembly of the pump.
- Before start-up of the pump anyone should acquaint oneself with the explanations of the chapter troubleshooting (see pages 13/14). Only by this the defect quickly can be realized and eliminated in case of trouble. Problems which cannot be solved or with an unknown reason should be passed on to the manufacturer.
- Before any maintenance and service procedures arising on the pump or on the optional equipments, the complete installation has to be turned off and protected against accidental turn on. This is possible by a lockable emergency stop for the air supply of the pump. Additional a danger sign against restart should be attached.
- Pressure tests of the plant a pump is included in may only be carried out with the pump disconnected from the pressure on both ports or by using the pressure the pump develops while operating. The load of a pressure in the plant may damage the pump.
- Pump must not be operated with a positive suction pressure.
- Depending on the conditions of operation, the liquid conveyed might escape from the pump through the muffler in case of a diaphragm rupture (in this case muffler has to be replaced). For further safety requirements the optional equipment diaphragm monitoring is recommended.
- In case of a diaphragm rupture, it might be possible for the fluid pumped to intrude into the air side of the pump. In very adverse conditions - e.g. pressure within the fluid system during stopped air supply - the fluid might as well find its way into the air supply lines. To protect other devices like pulsation dampers or even pneumatic valves, it is recommended to protect the air supply line accordingly, e.g. via a non-return valve. This would as well avoid polluting the air supply line.
- The state of the muffler has to be inspected regularly, as a blocked muffler can be forced out of the pump. If this happens, damages of properties and/or persons cannot be excluded.

- In case of delivery of hot liquids the wetted pump must not standstill for a longer time, because it could lead to temporary leaks in the valve area and to a blockade of the air control system.
- The relevant effective security advises have to be respected.
- Pools of liquid which appear in the near outer area of the pump have to be inspected on danger potential, if necessary safety measures are to be taken.
- Chemical and biological reactions in the product chamber of the pump (mixture of different substances) and the freezing of the liquid have to be avoided.
- Before starting to disassemble the pump, take care that the pump has been emptied and rinsed. Both ports piping are to be closed and drained if applicable. Further the pump has to be cut off from any energy on the air and product side. If the pump is being deported from the plant, a reference about the delivered liquid has to be attached.
- Procedure for rinsing: rinse the pump with neutral product, then turn around to the top, afterwards 90° to the side, and finally back to the top. Repeat this rinsing procedure several times.
- Please respect the relevant additional security advices, if the pump has been used for aggressive, dangerous or toxic liquids (e.g. suitable protective equipment according to the safety data sheet of the liquid). In case of a diaphragm rupture, it is possible that residues of the liquid remain behind the diaphragms, in the area of the air control system and at the muffler, despite of several flushing processes. Hence, appropriate safety equipment according to the safety data sheet of the liquid is indispensable.
-
- Additional advice for handling sensitive Fluids: With correct material choice, all wetted parts inside the pump are made from materials appropriate for your fluid. A malfunction, however, might result in a contact of the fluid to components that are non-wetted during normal operation (e.g. inside the air section). Therefore, we recommend as usual for pumps when handling sensitive fluids to discard the batch after a malfunction to avoid pollution.
- Although the wetted materials of a FUTUR-Pump are mostly suitable for food-contact solely, the construction and design of the pump is NOT to a “Hygienic Pump Construction”. We therefore recommend not to use the pump for transferring food stuff.
- Before putting the pump back into operation, the tightness of the pump has to be checked.
- Air-operated diaphragm pumps can lead to bruises when lifting, sinking or assembling them. Appropriate accessories and safety equipments are to be used. Big and heavy modules have to be fixed and secured to lifting gears when transporting/replacing them.
- Especially when delivering critical liquids, wear parts, like diaphragms, should be replaced within a preventive maintenance.
- The use of non-original ALMATEC spare parts and structural changes lead to the lapse of the warranty immediately. When operating such a pump, damages of properties and/or persons cannot be excluded.
- The operation of the pump with nitrogen as driving gas is possible. In closed rooms sufficient ventilation must be provided.
- Possible electrical connections (e.g. when using optional equipment with controllers) may be executed by a qualified person only. The regulations of the respective manufacturers are to be followed.
- At any work arising it has to be made sure that no explosive atmosphere can appear. Appropriate safety equipment is recommended.
- Procedure for pump return: According to the requirements of our 14001-certification, every unit which is sent to ALMATEC for diagnosis or maintenance reasons has to be accompanied by a filled out decontamination-sheet. Otherwise a processing is not possible. The decontamination-sheet is enclosed to this manual. Please pay attention to the further safety regulations.

Additional temperature hints

The temperature and pressure limitations listed on page 4 are solely based on mechanical temperature limits of the housing material used. Depending on the fluid pumped, the maximum safe operating temperature of the housing material can be reduced significantly.

A general aspect of lower temperatures is, that below 0°C cold-brittling of the elastomers used within the pumps can result in accelerated wear. Regarding the housing materials, please note that PE - other than PP - keeps its mechanical strengths at low temperatures and PTFE keeps mechanically stable as well for an extended temperature range. ALMATEC pumps can therefore be operated safely as well within low-temperature installations: However, with liquids below 0°C accelerated wear of internal parts has to be accepted. Moreover, freezing, bogging or crystallisation of the fluid pumped must be avoided, especially within the pump.

Please consider, that viscosity and specific gravity of most fluids change with temperature (most often increasing at lower temperature). Depending on the application, this fact may not only result in a reduced flow rate, the pump may even be unable to prime the thicker and/or "heavier" fluid any more.

Maintenance:

Only use original ALMATEC spare parts for repairs and / or preventive maintenance work. If this is not observed, the CE and ATEX markings, the declaration of conformity (s) and the guarantee claim for the pump will expire.

All work on the pump may only be carried out with the appropriate tools and by trained specialist personnel.

Disassembly

When dismantling a pump the mentioned procedures and safety notes on the pages 6 - 10 have to be considered generally.

On both sides of the pump unscrew the head screws [29,30] with a screwdriver and remove the base frame [25]. Take out O-rings air channel [26].

Screw the muffler [20] (at pump size 10 additionally the adapter muffler [21]) and the black plug [18] out of the side housing left hand [16]. Insert suitable round bar in one of the bore holes of the union nut [22] of the side housing left hand [16] and use it to unscrew the union nut [22]. Remove side housing left hand [16] from union nut [22]. Take the sliding ring [24] from the side housing left hand [16] and the O-ring union nut [23] from the union nut [22]. Unscrew the air valve cover [19] out of the side housing left hand [16] by using the mounting tool [36]. Lay down the side housing left hand [16] flat on the side and if necessary, the PERSWING P® air control system [35] (without pilot piston) can be shoved out completely to the air valve cover side. Take the piston rings diaphragm bolt [15] out of diaphragm bolt left hand [12]. Draw the pilot piston of the air control system out of the diaphragm bolt left hand [12].

Insert suitable round bar in one of the bore holes of the union nut [22] of the side housing right hand [14] and use it to unscrew the union nut [22]. Remove side housing right hand [14] from union nut [22]. Take the sliding ring [24] from the side housing right hand [14] and the O-ring union nut [23] from the union nut [22].

Place the center housing [1] upright with product connectors to the front. Draw the O-ring diaphragm outer [9] from both sides. Unscrew diaphragm bolt left hand [12] and diaphragm bolt right hand [13] out of the diaphragms [7]. Unscrew one of the diaphragms [7] out of the cascade sleeve [11]. Remove the second diaphragm [7] together with the cascade sleeve [11] and unscrew them. Check the O-ring diaphragm inner [8] and renew if necessary (twist prevention). Remove gaskets diaphragm [10], they have to be replaced in any case.

Disassembly of the product valves of models FUTUR T / H / E:

Stand the center housing [1] upright again to take out the discharge valves. Loosen both valve stops discharge valve [6] at the top of the center housing [1] using the mounting tool [36]. Take out the exposed check valves [4]. One valve stop suction valve [5] is located at the front of the center housing [1] (between the product connectors), the other one at the rear. Unscrew both with the mounting tool [36] and draw the check valves [4] out of the center housing [1] sideways.

Disassembly of the product valves of models FUTUR S / SH:

Put the center housing [1] upwards again to remove the check valves [4]. Loosen the two valve stops [5] at the top of the center housing [1] with mounting tool [36] and remove gaskets valve stop [3]. Take out first the exposed discharge check valves [4], then the check valve housings [2] and the gaskets check valve housing [3]. Finally remove the suction check valves [4].

Assembly

The individual components are basically assembled in exactly the reverse order to that described for the disassembly. Therefore, this chapter contains mostly supplementary information.

One important aspect to be paid attention to is that all damaged sealing elements have to be replaced in any case. Piston rings [15] and gaskets diaphragm [10] must not be reused after being disassembled; new rings have to be fitted! The piston rings diaphragm bolt [15] are slashed, so it is easy to put them into the groove.

Press the whole cartridge of the PERSWING P® air control system [35] (without pilot piston) from the air valve cover side into the side housing left hand [16] (Attention: do not damage O-rings, moisten O-rings before assembly!).

The valve stops [5,6] must be screwed in until they match the surface of the center housing [1] flushly. For the FUTUR S / SH stainless steel models, the valve housings [2] must first be installed in such a way that the round windows in the upper area release the fluid channel. Then insert the gaskets valve housing [3]. Finally the valve stops [5,6] must be screwed in until they match the surface of the center housing [1] flushly.

Lay down the center housing [1] on the left hand side and insert the gasket diaphragm [10] carefully. Screw the diaphragm bolt right hand [13] into the diaphragm [7]. Screw the diaphragm [7] into the cascade sleeve [11] and push it into the center housing [1]. Insert the O-ring diaphragm outer [9] into the diaphragm recess. Position the side housing right hand [14] in that way that the straight surface with the air bore holes is parallel to the lower side of the center housing [1]. Put on the sliding ring [24]. Lay the O-Ring union nut [23] in the union nut [22] and screw in the union nut [22] in the center housing [1]. When screwing in the union nut [22], insert a round bar in a bore hole of the side housing right hand [14] to prevent its rotating.

Insert the gasket diaphragm into the left side of the center housing [1] carefully. To install the second diaphragm [7], the just mounted diaphragm [7] has to be subjected with compressed air. For this the middle air bore holes on the right hand side of the center housing [1] is to use. The air feeding has to maintain as long as the left hand diaphragm [7] is tight to the center housing [1]. Screw the diaphragm bolt left hand [12] into the diaphragm [7] and insert the pilot piston of the air control system [35] in the diaphragm bolt left hand [12]. The assembly of the side housing left hand [16] is to do analog to the described procedure of the side housing right hand [14]. Do not forget to insert the fifth O-ring air valve housing before screwing the air valve cover [19]. Finally screw in the muffler [20] and the plug [18].

Because the just installed gaskets diaphragm [10] need time to settle, the assembly of the pump has to be rested for at least two hours.

Pump size	10	20 (20S)	50 (50S)	100	200
in mm (tolerance + 0,3 / - 0,5 mm)	28,8	31,3 (37)	35,5 (45,8)	41,3	59,3

After this break tighten the both union nuts [22] according to the nominal dimensions of the table above (space between outer edge of the union nut and center housing). When doing this pay attention to the described lockpin of the side housings [14,16] and to the parallel array to the center housing [1].

Troubleshooting

Malfunction	Possible Reason	Solutions/Remarks
pump does not operate	air supply line blocked/closed muffler blocked working chambers blocked air control system defective discharge line blocked/closed	open air supply clean/replace muffler remove blockage replace air valve system clean/open line
pump operates unsteadily	piston rings worn air control system worn diaphragm rupture air control system soiled check valve blocked icing	replace piston rings replace air control system replace diaphragm, clean pump clean/replace air control system cleaning, removal of bulk particles improve air processing
air within liquid	suction line leaky container with liquid empty diaphragm rupture cavitation	seal suction line fill/new container replace diaphragm adapt suction lift, possibly install suction pressurised air chamber
insufficient discharge pressure	insufficient pressure/amount of driving air air supply line leaky air control system leaky check valve worn more air consuming components	increase air supply check/repair air supply replace air control system check/replace check valve increase pressure/amount of air
output decreases	air control system soiled icing air pressure drop suction line/inlet strainer soiled discharge line/outlet strainer soiled muffler blocked check valve worn change in viscosity more air consuming components	clean/replace air control system improve air processing: dryer/filter ensure sufficient supply of air cleaning cleaning replace the muffler replace valve change back/adjust pump increase pressure/amount of air
pump stops itself	icing of the air control system air pressure too low air pressure drop discharge line blocked air filter blocked valve closed air control system defective wear/leaking of air control system diaphragm rupture check valve blocked/worn	improve air processing: dryer/heater etc. increase air pressure ensure sufficient air supply clean discharge line clean air filter open valve replace air control system replace air control system replace diaphragm, clean pump clean/replace check valve

Malfunction	Possible Reason	Solutions/Remarks
pumps operates, however suction capacity insufficient	pump operates too fast operation beyond physical limits cavitation operation beyond pump capacity air cushion within suction/discharge line dry suction against discharge pressure valve filter within suction line closed valve filter within discharge line closed container with liquid empty vacuum inside the container wear of the check valves suction line leaky suction line blocked air pressure cushion at discharge check valve blocked	start more slowly adjust installation check, cool down adjust installation resp. install bigger pump bleed the line wet pump, start without pressure open valve/clean filter open valve/clean filter fill/new container bleed container replace valves seal suction line clean suction line bleed discharge line clean/replace valve
insufficient suction capacity after pump repair	connections tighten incompletely check valves inserted falsely	tighten/seal connections correct positioning of check valves
diaphragm overstrained	pressure within the plant/system inadmissible vacuum icing	ensure that pressure is only developed by the pump itself, check plant/valves, replace diaphragms check suction line, open valve improve air processing
leaking between housing parts	diaphragms overstrained	replace diaphragms
muffler grey	driving air too humid, icing	improve quality of driving air
muffler black	soiled, oily air	improve quality of driving air, install sensitive filter in suction line
pump is connected to air but does not operate	air control system blocked bulk particles/dirt chemical influence (O-rings swollen) valve closed in discharge line	clean/replace air control system clean pump, replace necessary parts, improve air quality check, replace damaged parts open valve
liquid leaves the pump via the muffler	diaphragm rupture	replace diaphragms, clean pump

Dimensions in mm

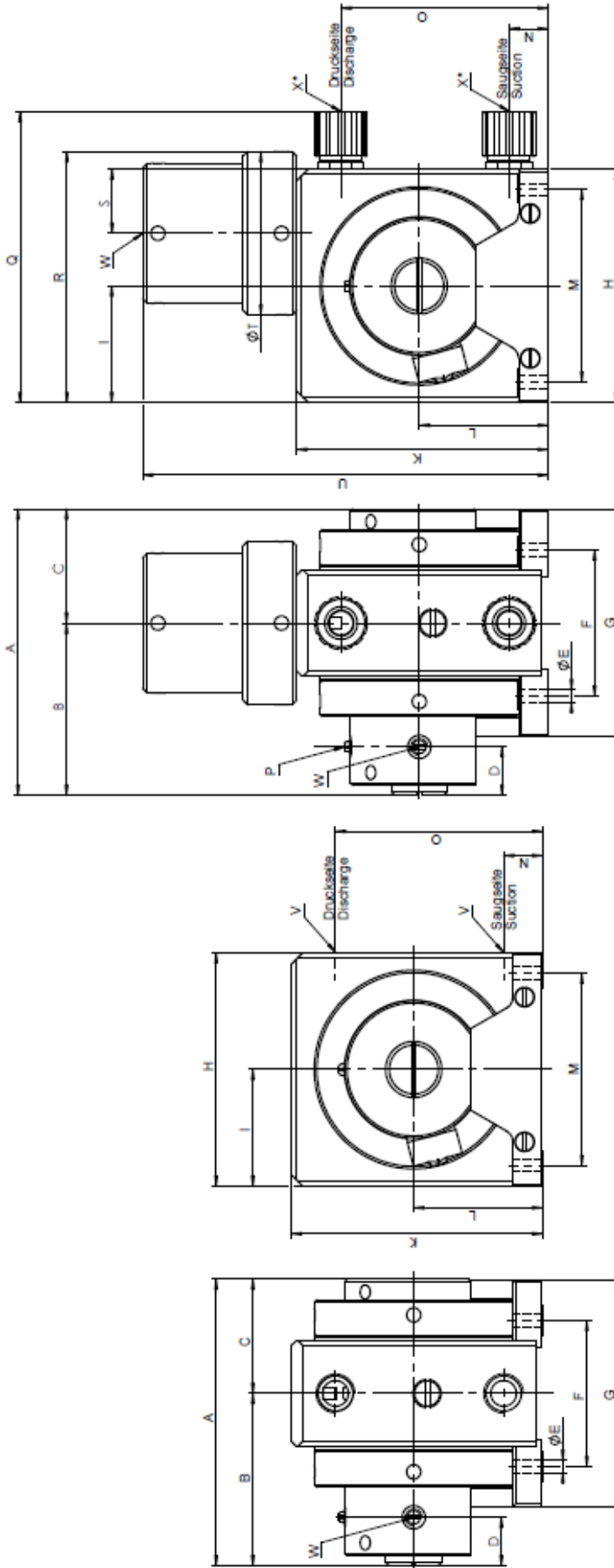

* Speziell modifiziert für FUTUR und werkseitig eingebaut.
Specially modified for FUTUR and fitted by the manufacturer.

	A	B	C	D	E	F	G	H	I	K	L	M	N	O	P (C9)	Q	R	S	T	U	V	W (Luft, air supply)	X*
FUTUR 10	185	112	73	35,5	10,5	93	143	114	57	131	72	79	35	104	NPT 1/4"	-155	136	33	110	246	NPT 3/8"	NPT 1/4"	1/2" Rohr-AD, 1/2" Pipe-OD (Flaretek®)
FUTUR 20	201	119	82	35,5	10,5	105	160	150	75	168	88	115	33	140	NPT 1/4"	-196	161	44	110	283	NPT 1/2"	NPT 1/4"	3/4" Rohr-AD, 3/4" Pipe-OD (Flaretek®)
FUTUR 50	246	148	98	41,5	10,5	125	194	200	100	216	111	165	34	178	NPT 1/4"	-251	215	55	140	348	NPT 1"	NPT 1/4"	1" Rohr-AD, 1" Pipe-OD (Flaretek®)
FUTUR 100	303	184	119	51	10,5	149	236	260	130	266	136	225	39	223	NPT 1/4"	-313	286	74	200	429	NPT 1 1/4"	NPT 1/4"	1 1/4" Rohr-AD, 1 1/4" Pipe-OD (Flaretek®)
FUTUR 200	374	215	159	51	10,5	227	314	330	165	346	181	290	61	281	NPT 1/4"	-	345	95	220	578	NPT 1 1/2"	NPT 3/8"	-
FUTUR 20 S	201	119	82	35,5	10,5	93	160	124	59	154	80	89	29	126	NPT 1/4"	-152	140	34	100	266	NPT 1/2"	NPT 1/4"	1/2" (VCR)
FUTUR 50 S	246	148	98	41,5	10,5	105	194	170	80	196	101	125	33	159	NPT 1/4"	-208	190	45	130	318	NPT 1"	NPT 1/4"	1" (VCR)

Spare part list FUTUR T / H / E

Pump size					FUTUR 10 T / H	FUTUR 20 T / H / E	FUTUR 50 T / H / E	FUTUR 100 T / E
Item	Pc.	Description	Pump code	Material	Part number	Part number	Part number	Part number
1	1	Center housing	T, H	PTFE-TFM	6 10 010 69	6 15 010 69	6 25 010 69	6 32 010 69
		Center housing	E	UPPE	-	6 15 010 52	6 25 010 52	6 32 010 52
4	4	Check valve	T, H	PTFE-TFM	8 10 011 69	8 15 011 69	8 25 011 69	8 32 011 69
		Check valve	E	UPPE	-	8 15 011 52	8 25 011 52	8 32 011 52
5	2	Valve stop, suction valve	T, H, E	PTFE-TFM	8 10 812 69	8 15 812 69	8 25 812 69	8 32 812 69
6	2	Valve stop, discharge valve	T, H, E	PTFE-TFM	8 10 813 69	8 15 813 69	8 25 813 69	8 32 813 69
7	2	Diaphragm	T, H	PTFE	6 10 020 69	6 15 020 69	6 25 020 69	6 32 020 69
		Diaphragm	E	PTFE	-	6 15 220 66	6 25 220 66	6 32 220 66
8	2	O-ring, diaphragm inner	T, H, E	FKM	9 04 593 74	9 06 538 74	9 10 544 74	9 15 546 74
9	2	O-ring, diaphragm outer	T, H, E	FKM	9 66 533 74	9 90 586 74	9 99 609 74	9 99 612 74
10	2	Gasket diaphragm	T, H, E	PTFE	6 10 026 69	6 15 026 69	6 25 026 69	6 32 026 69
11	1	Cascade sleeve	T, H, E	PTFE-TFM	6 10 032 69	6 15 032 69	6 25 032 69	6 32 032 69
12	1	Diaphragm bolt, left hand	T, H, E	PEEK	6 10 021 86	6 15 021 86	6 25 021 86	6 32 021 86
13	1	Diaphragm bolt, right hand	T, H, E	PEEK	6 10 023 86	6 15 023 86	6 25 023 86	6 32 023 86
14	1	Side housing, right hand	T, E	UPPE/PA	6 10 014 52	6 15 014 52	6 25 014 52	6 32 014 52
		Side housing, right hand	H	PTFE conductive	6 10 014 65	6 15 014 65	6 25 014 69	-
15	2	Piston ring, diaphragm bolt	T, H, E	PTFE-PPS	8 10 825 61	8 15 825 61	8 25 825 61	8 32 825 61
16	1	Side housing, left hand	T, E	UPPE/PA	6 10 015 52	6 15 015 52	6 25 015 52	6 32 015 52
		Side housing, left hand	H	PTFE conductive	6 10 015 65	6 15 015 65	6 25 015 69	-
17	1	Set screw DIN 551	T, H, E	PA	9 06 201 53	9 06 201 53	9 10 206 53	9 12 207 53
18	1	Plug GPN 730	T, H, E	PA	730 R 1/4	730 R 1/4	730 R 1/4	730 R 1/4
19	1	Air valve cover	T, H, E	PE	8 15 731 52	8 15 731 52	8 25 731 52	8 32 731 52
20	1	Muffler, cpl.	T, H, E	PE	1 08 244 51	1 08 244 51	1 15 244 51	1 40 244 51
21	1	Adapter, muffler	T	PE	6 10 033 52	-	-	-
22	2	Union nut	T	PE	6 10 029 80	6 15 029 80	6 25 029 80	6 32 029 80
		Union nut	H	PEEK	6 10 029 86	6 15 029 86	6 25 029 86	-
		Union nut	E	PA	-	6 15 029 53	6 25 029 53	6 32 029 53
23	2	O-ring, union nut	T, H, E	FKM	9 73 660 74	9 98 661 74	9 99 662 74	9 99 663 74
24	2	Sliding ring	T, H, E	PTFE	6 10 030 60	6 15 030 60	6 25 030 60	6 32 030 60
25	2	Base frame	T, H, E	PE/PA	6 10 017 52	6 15 017 52	6 25 017 52	6 32 017 52
26	4	O-ring, air channel	T, H, E	FKM	9 06 538 74	9 06 538 74	9 08 541 74	9 10 544 74
27	4	Anchor bolt bushing	T, H, E	PE	8 25 418 52	8 25 418 52	8 25 418 52	8 25 418 52
28	8	Damper ring	T, H, E	FKM	1 15 149 74	1 15 149 74	1 15 149 74	1 15 149 74
29	4	Head screw DIN 84	T, H, E	PA	9 06 226 53	9 06 227 53	9 08 227 53	9 08 227 53
30	4	Head screw DIN 84	T, H, E	PA	9 10 227 53	9 10 227 53	9 10 227 53	9 10 227 53
35	1	PERSWING P® air control system, cpl.	T, H, E	PETP	6 10 201 84	6 15 201 84	6 25 201 84	6 32 201 84
36	1	Mounting tool	T, H, E	PA	6 10 000 53	6 10 000 53	6 10 000 53	6 10 000 53

Exploded view FUTUR T / H / E

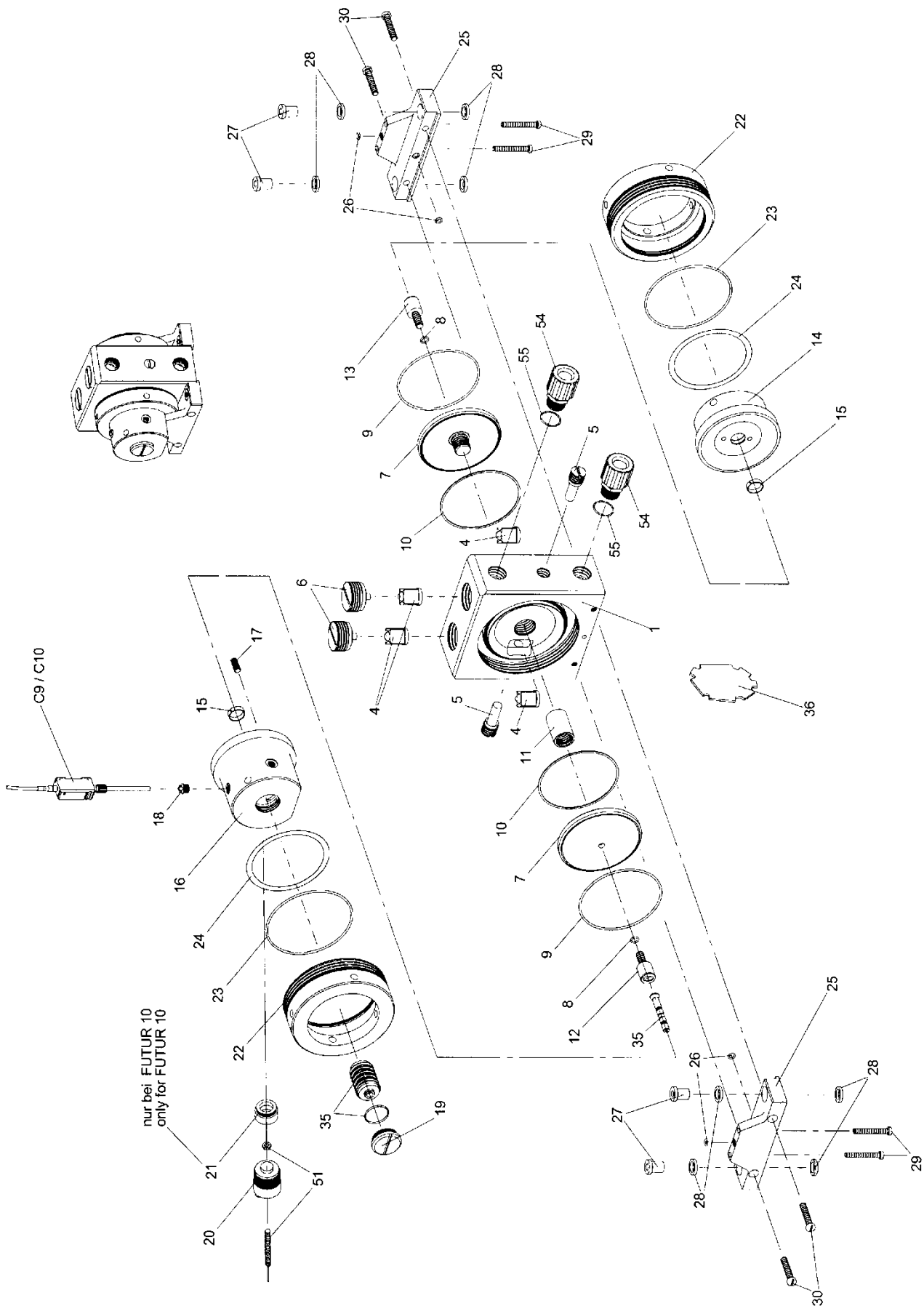

Spare part list FUTUR S / SH

Pump size					FUTUR 20 S / SH	FUTUR 50 S / SH
Item	Pc.	Description	Pump code	Material	Part number	Part number
1	1	Center housing	S, SH	SS316L	6 15 110 23	6 25 110 23
2	2	Valve housing	S, SH	SS316L	8 15 912 23	8 25 912 23
3	2	Gasket, valve housing	S, SH	PTFE	8 15 928 60	8 25 928 60
4	4	Check valve	S, SH	PTFE	8 15 011 69	8 25 011 69
5	2	Valve stop	S, SH	SS316L	8 15 913 23	8 25 913 25
6	2	Gasket, valve stop	S, SH	PTFE	8 15 929 60	8 25 929 60
7	2	Diaphragm	S, SH	PTFE	6 15 420 69	6 25 420 69
8	2	O-ring, diaphragm inner	S, SH	FKM	9 06 538 74	9 10 544 74
9	2	O-ring, diaphragm outer	S, SH	FKM	9 90 586 74	9 99 609 74
10	2	Gasket diaphragm	S, SH	PTFE	6 15 026 69	6 25 026 69
11	1	Cascade sleeve	S, SH	PTFE	6 15 032 69	6 25 032 69
12	1	Diaphragm bolt, left hand	S, SH	PEEK	6 15 021 86	6 25 021 86
13	1	Diaphragm bolt, right hand	S, SH	PEEK	6 15 023 86	6 25 023 86
14	1	Side housing, right hand	S	PE conductive	6 15 014 56	6 25 014 56
		Side housing, right hand	SH	SS316	6 15 014 22	6 25 014 22
15	2	Piston ring, diaphragm bolt	S, SH	PTFE-PPS	8 15 825 61	8 25 825 61
16	1	Side housing, left hand	S	PE conductive	6 15 015 56	6 25 015 56
		Side housing, left hand	SH	SS316	6 15 015 22	6 25 015 22
17	1	Set screw DIN 551	S	PA	9 06 201 53	9 10 206 53
		Set screw DIN 551	SH	PA	9 06 202 53	9 10 207 53
18	1	Plug GPN 730	S, SH	PA	730 R 1/4	730 R 1/4
19	1	Air valve cover	S, SH	PE	8 15 731 52	8 25 731 52
20	1	Muffler, cpl.	S, SH	PE	1 08 244 51	1 15 244 51
22	2	Union nut	S, SH	SS316	6 15 129 22	6 25 129 22
23	2	O-ring, union nut	S, SH	FKM	9 98 661 74	9 99 662 74
24	2	Sliding ring	S, SH	PTFE	6 15 030 60	6 25 030 60
25	2	Base frame	S, SH	PE conductive	6 15 117 56	6 25 117 56
26	4	O-ring, air channel	S, SH	FKM	9 06 538 74	9 08 541 74
27	4	Anchor bolt bushing	S, SH	PE	8 25 418 52	8 25 418 52
28	8	Damper ring	S, SH	FKM	1 15 149 74	1 15 149 74
29	4	Head screw DIN 84	S, SH	PA	9 06 227 53	9 08 229 53
30	4	Head screw DIN 84	S, SH	PA	9 10 227 53	9 10 227 53
35	1	PERSWING P® air control system, cpl.	S, SH	PETP	6 15 201 84	6 25 201 84
36	1	Mounting tool	S, SH	PA	6 10 000 53	6 10 000 53

Exploded view FUTUR S / SH

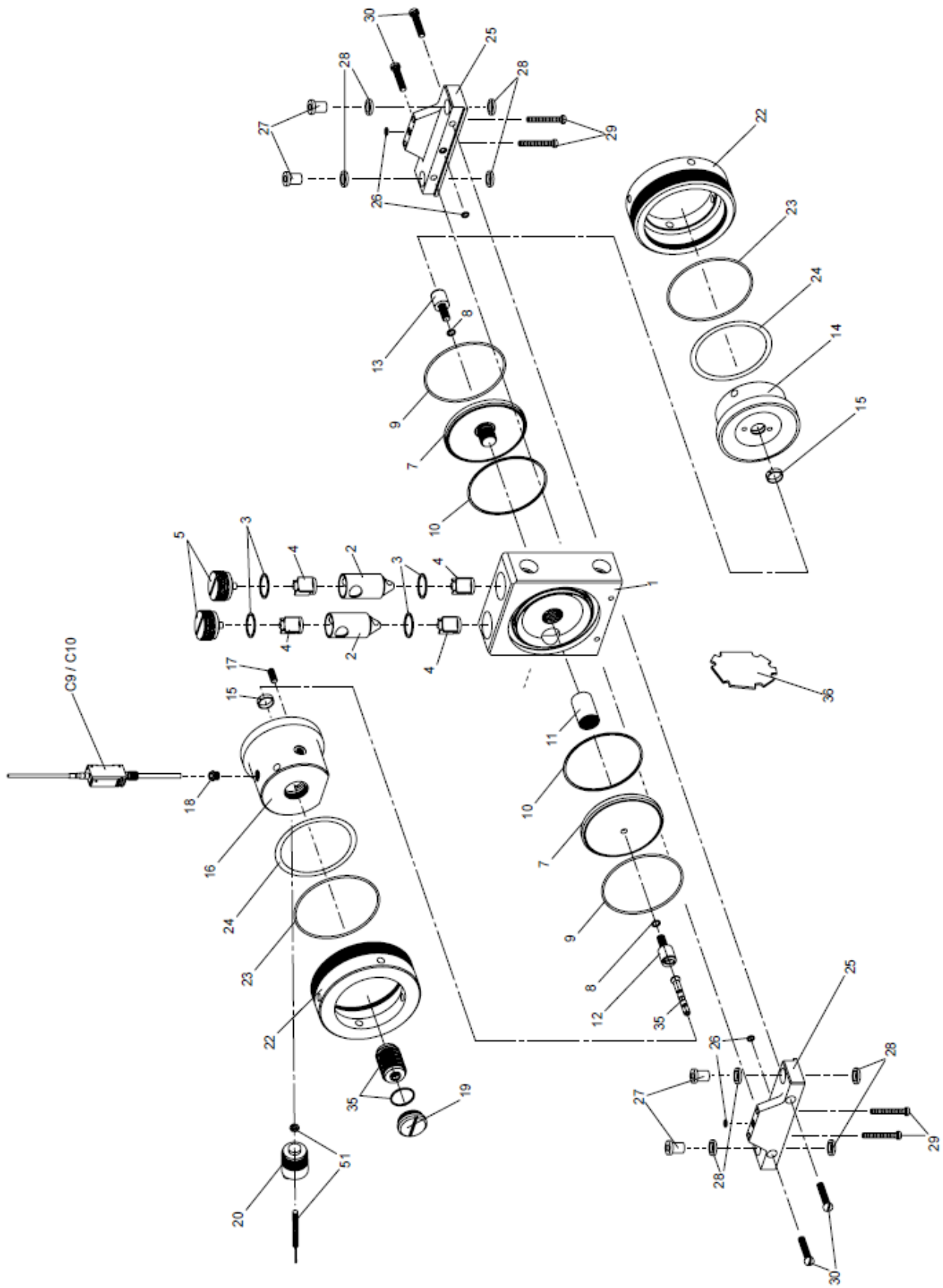

Special equipment

Pneumatic stroke counting (code C 9 / C 10)

On the codes C 9 / C 10 the strokes of the pump are registered pneumatically. The pressure sensor registers the changes in pressure within the air chamber behind one of the diaphragms.

The pneumatic stroke counting system is available in two types:

- C 9 consisting of:
 - Pressure sensor incl. 2,5 m cable and plug for pressure sensor
 - 2,5 m connection hose DN 4/6 with screwed connectors (pump side & sensors side) for hose 4/6
 - Mounting bracket with screws
- C 10 consisting of:
 - As C 9 however including stroke counter

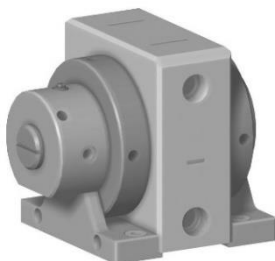

Assembly: Remove the black plug [18] (see arrow) out of the additional air connection of the side housing left hand [16] and screw in the adapter straight. Link up the adaptor straight and the pressure switch with the hose. Connect the socket to the electrical connection plug of the pressure switch and the cable to existing registering devices (code C 9) resp. to the enclosed stroke counter (code 10). Technical data, connection schemes and further details can be found in the technical documentation delivered by the manufacturers of the pressure transmitter and the stroke counter.



The pneumatic stroke counting system requires a minimum counter pressure of 1.5 bar for optimal function!

Diaphragm monitoring sensor (code D)

The diaphragm sensor is installed into the muffler of the pump and registers any liquid, regardless of its conductivity. Hence, an immediate reaction after a diaphragm rupture is possible. However, it has to be considered, that the diaphragm monitoring possibly cannot prevent that liquid can leave the pump via the muffler. In case of humid surrounding air a false alert may occur despite operating the pump with dried compressed air. Diaphragm monitoring is available in three variations:

- * D 1 Diaphragm sensor, 2-wire-Namur, intrinsically safe EEx ia IIC T6
- * D 5** Diaphragm sensor, 3-wire *[No more available for new pumps]*
- * D 6** Diaphragm sensor, 3-wire with plug *[No more available for new pumps]*

For further details, please refer to the data delivered by the manufacturer.

Flaretek®-connectors for PFA-pipe (code G)

The suction and the discharge ports of the FUTUR T and FUTUR H can be equipped with Flaretek®-connectors for PFA piping which are widely used in the semiconductor industry. The Flaretek®-connectors are fitted by the manufacturer and must not be removed or replaced! They have been specially modified for the FUTUR and have been fitted in gas-tight. The correct functioning, sealing and purity of the pumps can only be warranted with these original product connectors!

VCR-connectors (code V)

Suction and the discharge port of the FUTUR S/SH pumps can optionally be equipped with VCR-connectors [52] made of stainless steel (size 20 for 1/2" pipe, size 50 for 1" pipe) including a gasket [53].

Spare part list for special equipment

Pump size					FUTUR 10	FUTUR 20	FUTUR 50	FUTUR 100
Item	Pc.	Description	Pump code	Material	Part number	Part number	Part number	Part number
18	1	C 9: Adaptor straight	T, H, E	PP	1 00 877 51	1 00 877 51	1 00 877 51	1 00 877 51
	1	Hose	T, H, E	PE	1 00 876 51	1 00 876 51	1 00 876 51	1 00 876 51
	1	Pressure switch	T, H, E	diverse	1 00 972 99	1 00 972 99	1 00 972 99	1 00 972 99
	1	Socket with cable	T, H, E	diverse	1 00 973 99	1 00 973 99	1 00 973 99	1 00 973 99
-	1	C 10: Stroke counter	T, H, E	diverse	1 00 071 99	1 00 071 99	1 00 071 99	1 00 071 99
51	1	D 1: Diaphragm sensor, 2-wire-Namur	T, H, E	PBTP	1 00 773 99	1 00 773 99	1 00 773 99	1 00 773 99
51	1	D 5: Diaphragm sensor, 3-wire	T, H, E	PTFE	1 00 473 99	1 00 473 99	1 00 473 99	1 00 473 99
51	1	D 6: Diaphragm sensor, 3-wire with plug	T, H, E	PTFE	1 00 573 99	1 00 573 99	1 00 573 99	-
-	2	G: Flaretek®-connector for PFA-pipe	T	PFA/PVDF	1 10 012 57	1 15 012 57	1 25 012 57	1 32 012 57
-	2	Flaretek®-connector for PFA-pipe	H	PFA/PFA	1 10 312 57	1 15 312 57	1 25 312 57	-
-	2	O-ring, Flaretek®-connector	T, H	FKM/FEP	9 16 559 74	9 18 501 74	9 28 534 74	9 30 582 59
-	2	V: VCR-connector	S, SH	SS316L	-	8 15 638 23	8 25 638 23	-
-	2	Gasket for VCR	S, SH	PTFE	-	8 15 639 60	8 25 639 60	-

Use of a pulsation damper D series

Due to their design, oscillating displacement pumps deliver a pulsating flow. This pulsation is considerably reduced by the appropriately designed air distribution channels and air chambers of the FUTUR series, as well as by the cascade seal, also on the suction side. Pulsation dampers of the same design (type D) without tie rods are available for all pump sizes, if the remaining pulsation on the discharge side is unacceptable for a specific application. A separate pulsation damper can be retrofitted at any time, even on installed pumps, without changing the product connections. A general aspect to be considered is, that a pulsation damper decreases the total capacity of the system depending on the point of operation.

Before putting an ALMATEC pulsation damper into operation, make sure, that the materials of construction are resistant to the chemical to be pumped.

In the following text, all mentioned parts of the pulsation damper are marked with a number, which is identical with the item number, shown in the spare part list as well as the exploded view drawing.

Safety hints

For installation, operation, disassembly and assembly please consider also the remarks and safety hints of the pump (see page 6 - 10 of this manual).

Installation and operation

The delivery of the FUTUR pump and the D pulsation damper will be carried out in separate packaging for safety reasons. To install the pulsation damper, the front-sided discharge valve stop of the pump must be removed (see exploded view drawing on page 19).

O-ring damper housing [2] should be checked for correct seating in the groove. Unless done before, set the pump upright on its feet and ensure the correct position of the check valve within the pump. Now the damper has to be screwed into the pump carefully, but only until the damper is in contact with the pump. Exceeded tightening may damage the thread.

The connection for the air supply is located on the top of the damper head [3]. For proper function, the damper needs its own and separate air connection, starting at the air connection of the pump. Do not place any kind of stop or regulation valves between the pump and damper air supply. Pump and damper should receive the same air pressure at any time. Concerning the quality of the air, the minimum demands given with the technical-data (shown on page 2) are valid. The pulsation damper requires a minimum counter pressure of at least 1 bar for optimal function. Pump and damper must not be operated with a positive suction pressure.

Together with the pump an empty damper has to be driven slowly. The dampers are self-regulating for all changing operating conditions.

Disassembly and assembly

Remove damper from the FUTUR pump by unscrewing it. While doing this, keep attention to the O-ring damper housing [2]. Separate damper housing [1] and damper head [3] by unscrewing them. Take out O-ring diaphragm outer [11] carefully. Pull out diaphragm [9] incl. actuator shaft [13]. Remove gasket diaphragm [12]. Check the O-ring diaphragm inner [10] and renew if necessary (twist prevention). Take out piston rings [5] and O-rings piston ring [6]. Remove O-ring damper head [4].

The assembly of the damper is according the above description, only in reverse order. Therefore only a few remarks according the assembly will follow.

Basically it is to be considered, that all damaged or dirty sealing elements have to be renewed before re-assembly. Removed gaskets and the piston rings have to be renewed in any case. Bend the new piston ring [5] until shaped like a kidney and place it into the groove. After this, the upstanding arch is to be pressed completely into the groove with the use of a round tool. With the change of the piston rings [5], the O-rings [6] have to be renewed as well. Before putting the diaphragm [9] back in place, the O-ring diaphragm outer [11] has to be laid in the appropriate groove of the diaphragm [9].

Because the gasket diaphragm [12] needs time to settle, after the complete assembly of the pulsation damper the further working has to be rested for at least two hours. After this break tighten the housing parts and only now mount the damper on the pump.

Technical data

Damper code	D 10/20/50/100 T/H/S/SH
Dimensions (mm)	Please see page 15
Air connection (NPT)	1/4"
Air classification acc. to ISO-DIS 8573-1:	
solids, class	2
water, class	3
oil, class	3
Max. permissible driving pressure (bar)	6
Max. permissible temperature (°C)	
at max. 6 bar pressure	100
at max. 5 bar pressure	110
at max. 4 bar pressure	120
at max. 3 bar pressure	130
at max. 2 bar pressure	130

Max. permitted operating in °C					
Pump model	FUTUR H	FUTUR T	FUTUR E	FUTUR S	FUTUR SH
at max. 6 bar	100	100	70	80	130
at max. 5 bar	130	110	70	80	130
at max. 4 bar	150	120	70	80	130
at max. 3 bar	180	130	70	80	130
at max. 2 bar	200	130	70	80	130

FUTUR E pumps will be equipped with T damper.

Spare part list damper

Damper size					D10 T/H	D20 T/H/S/SH	D50 T/S/SH	D 100T
Item	Pc.	Description	Damper-code	Material	Part-No.	Part-No.	Part-No	Part-No.
1	1	Damper housing	T/H	PTFE-TFM	6 10 040 69	6 15 040 69	6 25 040 69	6 32 040 69
		Damper housing	S/SH	SS316L	-	6 15 140 23	6 25 140 23	
2	1	O-ring, damper housing	T/H	EPDM	9 42 540 72	9 51 513 72	9 65 516 72	9 78 530 72
3	1	Damper head	T	UPPE	6 10 041 52	6 10 041 52	6 25 041 52	6 32 041 52
		Damper head	H/S	PTFE cond.	6 10 041 65	6 10 041 65	6 25 041 65	-
		Damper head	SH	SS316	-	6 10 041 22	6 25 041 22	-
4	1	O-ring, damper head	T/H/S/SH	FKM	9 73 660 74	9 73 660 74	9 98 661 74	9 99 662 74
5	3	Piston ring	T/H/S/SH	PTFE-PPS	1 08 153 61	1 08 153 61	1 08 153 61	8 25 431 61
6	3	O-ring, piston ring	T/H/S/SH	FKM	9 13 575 74	9 13 575 74	9 13 575 74	9 18 501 74
7	1	Muffler	T/H/S/SH	PE	1 08 644 51	1 08 644 51	1 08 644 51	8 32 644 51
8	1	Supporting disc	T/H/S/SH	PA	8 10 884 53	8 10 884 53	8 15 884 53	8 32 884 53
9	1	Damper diaphragm	T/H/S/SH	PTFE	6 10 043 69	6 10 043 69	6 25 043 69	6 32 043 69
10	1	O-ring, diaphragm inner	T/H/S/SH	FKM	9 08 541 74	9 08 541 74	9 08 541 74	9 10 544 74
11	1	O-ring, diaphragm outer	T/H/S/SH	FKM	9 66 533 74	9 66 533 74	9 90 586 74	9 99 609 74
12	1	Gasket, diaphragm	T/H/S/SH	PTFE	6 10 026 69	6 10 026 69	6 15 026 69	6 25 026 69
13	1	Actuator shaft	T/H/S/SH	PEEK	8 15 482 86	8 15 482 86	8 15 482 86	8 32 482 86

When ordering please state the serial number of the pulsation damper!

Exploded view damper

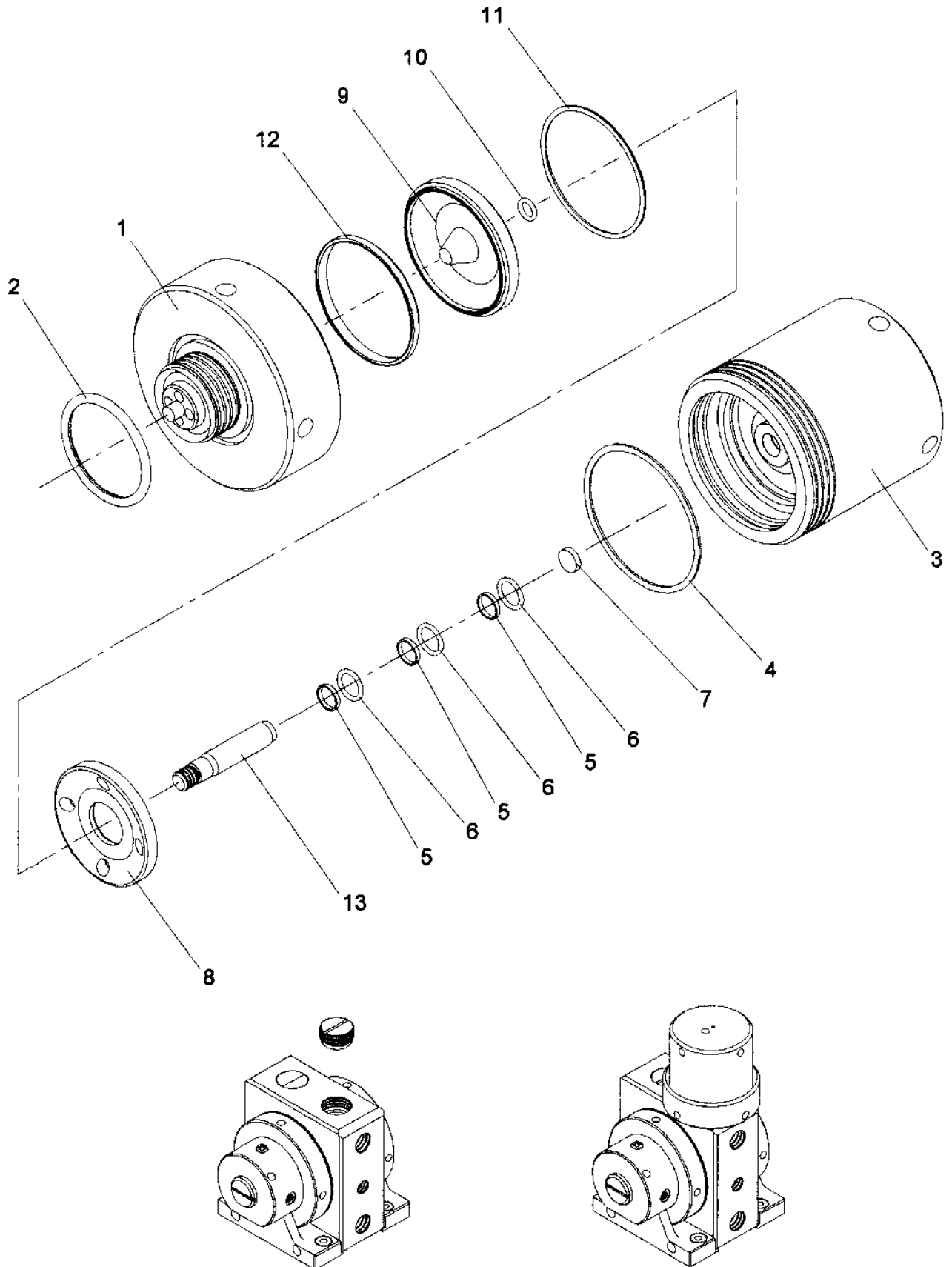



a **DOVER** company

Subject to change without notice, 2023/10

PSG Germany GmbH
Hochstraße 150-152 · 47228 Duisburg · Germany
Telephone +49 (0) 20 65 / 89 2 05 - 0 · Telefax +49 (0) 20 65 / 89 2 05 - 40
<http://www.psgdover.com> · e-mail: psg-germany@psgdover.com