

SPECIFICATIONS SHEET

F100 – 1 in. All-Pur™ FDA Pump



Air Inlet
1/4" FNPT

Liquid Inlet
1-1/2"

Liquid Discharge
1-1/2"

Connection Type
Tri-Clamp

Max Suction Lift Capability
17 ft-H₂O (5.2 m-H₂O) Dry
30 ft-H₂O (9.1 m-H₂O) Wet

Max Flow Rate
48 gpm (182 lpm)

Max Pressure
120 psi (8.2 bar)

Max Solids Dia.
1/4" (6.4 mm)

Weight
38 lbs (17 kg)

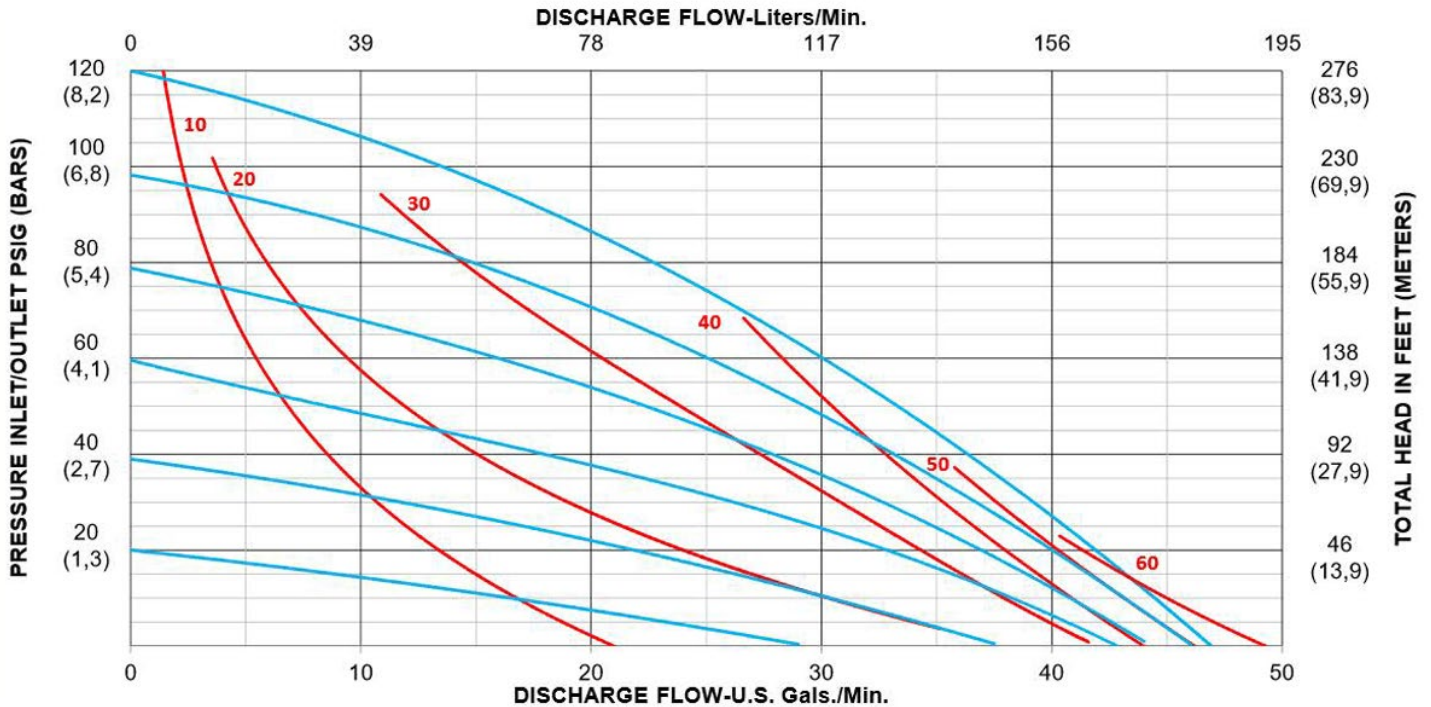

PSG
All-Flo
22069 Van Buren Street
Grand Terrace, CA 92313, USA

P: +1 (440) 354-1700
F: +1 (440) 354-9466

all-flo.com



SPECIFICATIONS SHEET

F100 – 1 in. All-Pur™ FDA Pump

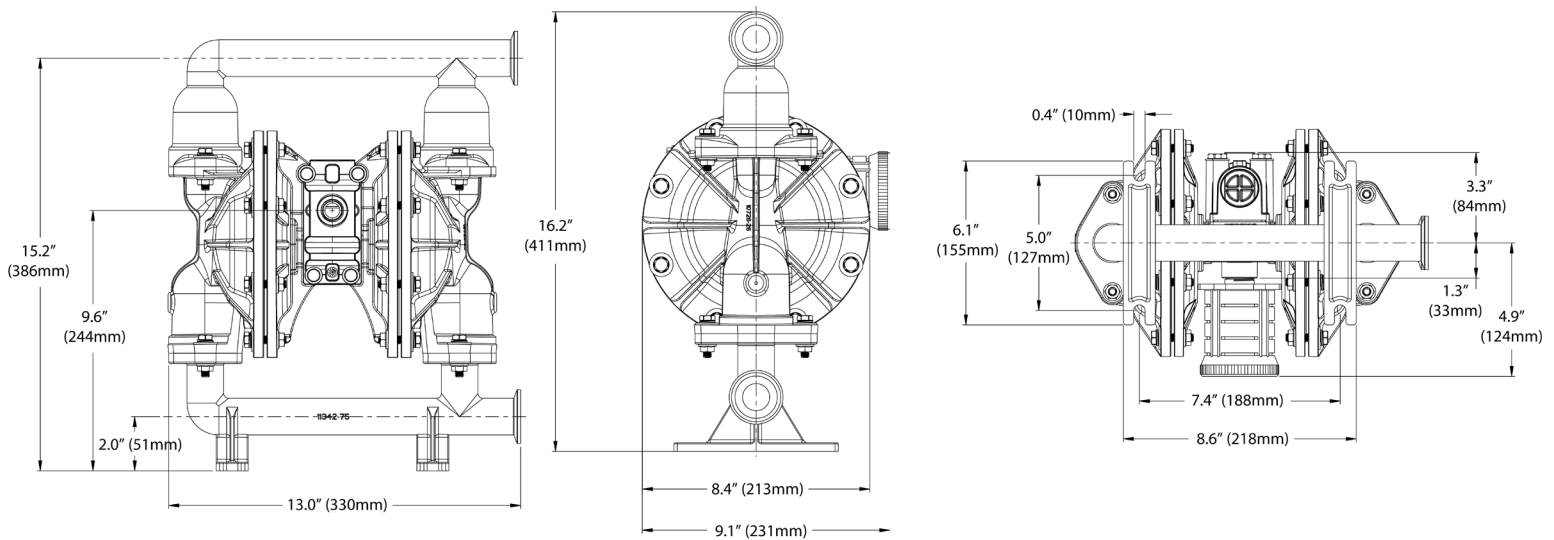

Construction

Wet End:	Passivated Stainless Steel
Air End:	Aluminum
Diaphragms:	Hytrel™, PTFE With Santoprene® backup, Santoprene®
Balls:	Buna-N, PTFE, Santoprene®
Seats:	Stainless Steel
O-Rings:	Buna-N, EPDM, PTFE
Hardware:	Stainless Steel
Muffler:	Plastic, Metal

Popular Models

F100-TAE-TT3T-S70	Passivated Stainless Steel, Tri-Clamp, PTFE Diaphragm, PTFE Ball, Stainless Steel Seat, PTFE O-Ring, Stainless Steel Hardware
F100-TAE-4S3M-S70	Passivated Stainless Steel, Tri-Clamp, Santoprene® [FDA] Diaphragm, Santoprene® Ball, Stainless Steel Seat, EPDM [FDA] O-Ring, Stainless Steel Hardware
F100-TAE-HB3B-S70	Passivated Stainless Steel, Tri-Clamp, Hytrel® [FDA] Diaphragm, Buna-N [FDA] Ball, Stainless Steel Seat, Buna-N [FDA] O-Ring, Stainless Steel Hardware

SPECIFICATIONS SHEET

F100 – 1 in. All-Pur™ FDA Pump



PSG
All-Flo
22069 Van Buren Street
Grand Terrace, CA 92313, USA

P: +1 (440) 354-1700
F: +1 (440) 354-9466

all-flo.com

