

# SPECIFICATIONS SHEET

## C038 – 3/8 in. PLASTIC PUMP



**Air Inlet**  
1/4" FNPT

**Liquid Inlet**  
3/8"

**Liquid Discharge**  
3/8"

**Connection Type**  
FNPT/FBSPT (Threaded)

**Max Suction Lift Capability**  
10 ft-H<sub>2</sub>O (3.0 m-H<sub>2</sub>O) Dry  
26 ft-H<sub>2</sub>O (7.9 m-H<sub>2</sub>O) Wet

**Max Flow Rate**  
9 gpm (34.0 lpm)

**Max Pressure**  
120 psi (8.2 bar)

**Max Solids Dia.**  
1/16" (6.4 mm)

**Disp. Per Stroke**  
0.01 gal (0.04 L)

**Weight**  
Poly: 3.8 lbs (1.7 kg)  
PVDF: 5 lbs (2.3 kg)  
Nylon: 3.8 lbs (1.7 kg)

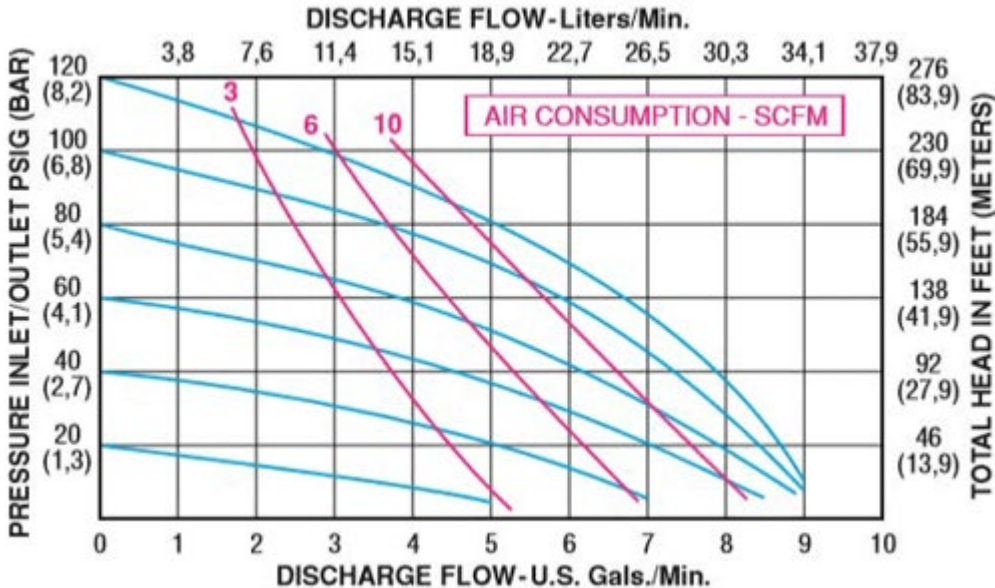

# SPECIFICATIONS SHEET

## C038 – 3/8 in. PLASTIC PUMP

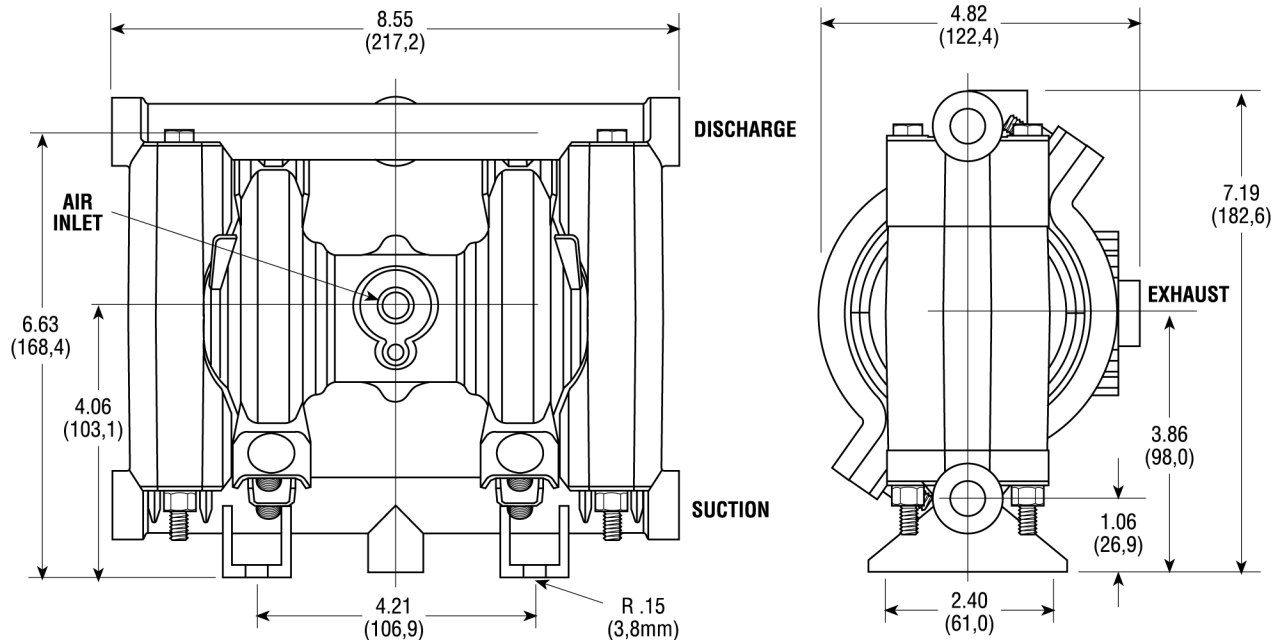

### Construction

<b>Wet End:</b>	Polypropylene, PVDF, Conductive Nylon
<b>Air End:</b>	Glass Filled Polypropylene
<b>Diaphragms:</b>	Bunast <sup>™</sup> , PTFE, Santoprene <sup>®</sup>
<b>Balls:</b>	Bunast <sup>™</sup> , PTFE, Santoprene <sup>®</sup> , FKM
<b>Seats:</b>	Polypropylene, PVDF
<b>O-Rings:</b>	Buna-N, EPDM, PTFE, FKM
<b>Hardware:</b>	PTFE Coated Stainless Steel, Stainless Steel
<b>Muffler:</b>	Plastic, Metal

### Popular Models

<b>C038-SQP-GNPN-S70</b>	Polypropylene, NPT(BSP), Bunast <sup>™</sup> Diaphragm, Bunast <sup>™</sup> Ball, Polypropylene Seat, Buna-N O-Ring, Stainless Steel Hardware
<b>C038-SQP-SSPE-S70</b>	Polypropylene, NPT(BSP), Santoprene <sup>®</sup> Diaphragm, Santoprene <sup>®</sup> Ball, Polypropylene Seat, EPDM O-Ring, Stainless Steel Hardware
<b>C038-SQP-TTPT-S70</b>	Polypropylene, NPT(BSP), PTFE Diaphragm, PTFE Ball, Polypropylene Seat, PTFE O-Ring, Stainless Steel Hardware
<b>C038-SQK-SSKE-S70</b>	PVDF, NPT(BSP), Santoprene <sup>®</sup> Diaphragm, Santoprene <sup>®</sup> Ball, PVDF Seat, EPDM O-Ring, Stainless Steel Hardware
<b>C038-SQK-TTKV-S70</b>	PVDF, NPT(BSP), PTFE Diaphragm, PTFE Ball, PVDF Seat, FKM O-Ring, Stainless Steel Hardware