

SPECIFICATIONS SHEET

A100 – 1 in. PLASTIC PUMP



Air Inlet
1/4" FNPT

Liquid Inlet
1"

Liquid Discharge
1"

Connection Type
FNPT/FBSPT (Threaded)
ANSI/DIN (Flanged)

Max Suction Lift Capability
15 ft-H₂O (4.6 m-H₂O) Dry
26 ft-H₂O (7.9 m-H₂O) Wet

Max Flow Rate
41 gpm (155.8 lpm)

Max Pressure
120 psi (8.2 bar)

Max Solids Dia.
1/4" (6.4 mm)

Disp. Per Stroke
0.08 gal (0.31 L)

Weight
Poly: 20 lbs (9.1 kg)
PVDF: 30 lbs (13 kg)

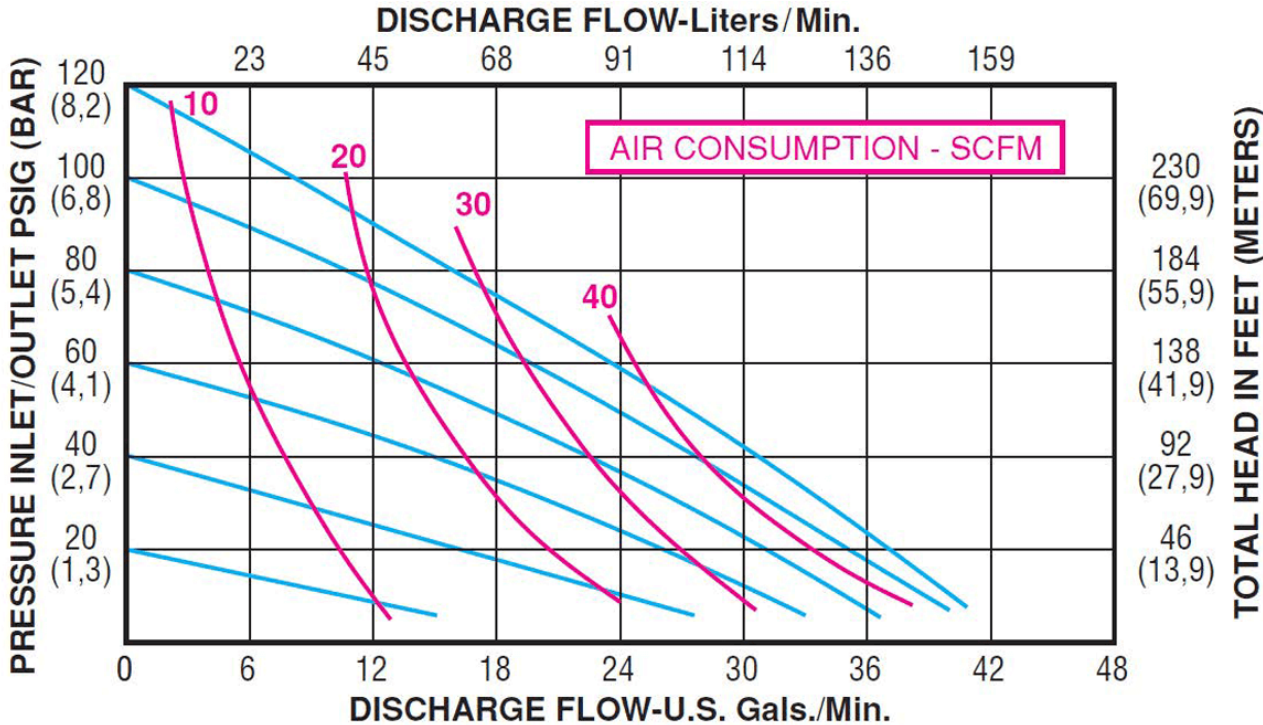

PSG
All-Flo
22069 Van Buren Street
Grand Terrace, CA 92313, USA

P: +1 (440) 354-1700
F: +1 (440) 354-9466

all-flo.com



SPECIFICATIONS SHEET

A100 – 1 in. PLASTIC PUMP

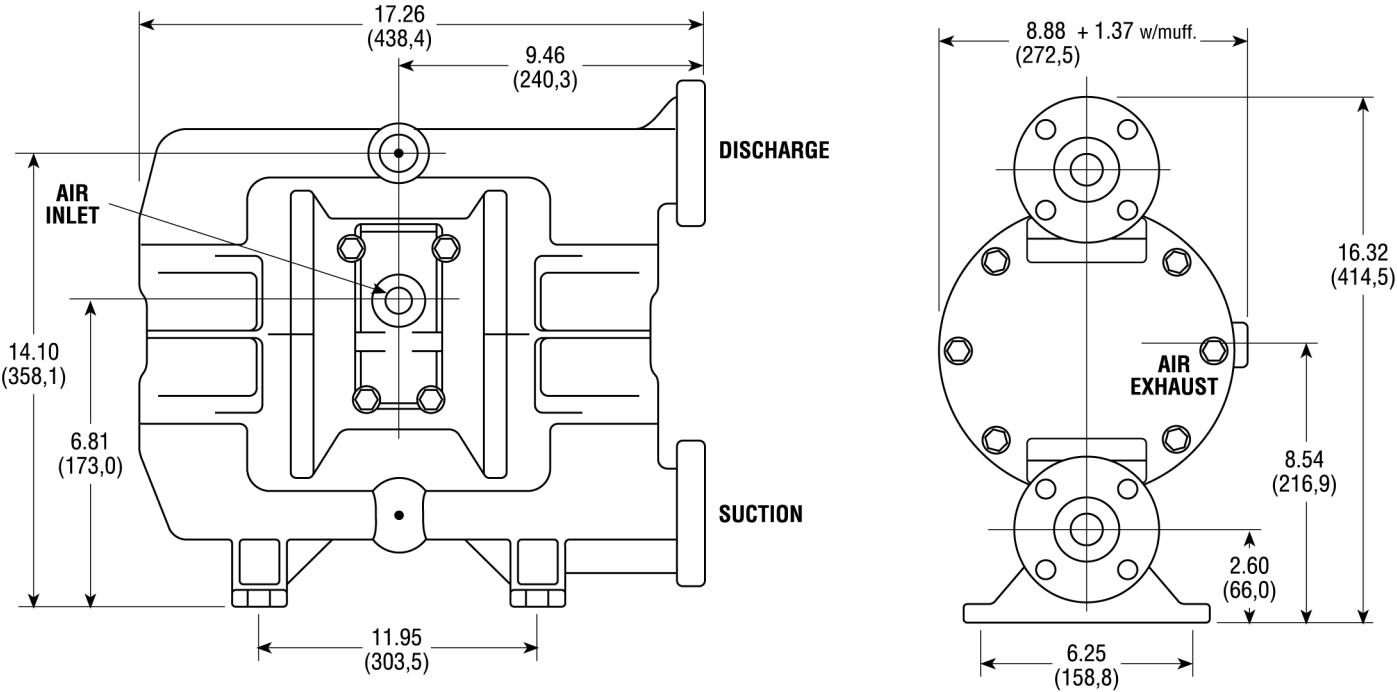

Construction	
Wet End:	Polypropylene, PVDF
Air End:	Glass Filled Polypropylene
Diaphragms:	Bunast™, PTFE With Santoprene® backup, Santoprene®, FKM
Balls:	Bunast™, PTFE, Santoprene®, FKM
Seats:	Polypropylene, PVDF
O-Rings:	Buna-N, EPDM, PTFE, FKM
Hardware:	PTFE Coated Stainless Steel, Stainless Steel
Muffler:	Plastic

Popular Models	
A100-FPP-GNPN-S70	ANSI/DIN Flange, Bunast™ Diaphragm, Buna-N Ball, Polypropylene Seat, Buna-N O-Ring, Stainless Steel Hardware
A100-FPP-SSPE-S70*	ANSI/DIN Flange, Santoprene® Diaphragm, Santoprene® Ball, Polypropylene Seat, EPDM O-Ring, Stainless Steel Hardware
A100-FPP-TTPT-S70*	ANSI/DIN Flange, PTFE Diaphragm, PTFE Ball, Polypropylene Seat, PTFE O-Ring, Stainless Steel Hardware
A100-FPK-SSKE-S70	ANSI/DIN Flange, Santoprene® Diaphragm, Santoprene® Ball, PVDF Seat, EPDM O-Ring, Stainless Steel Hardware
A100-FPK-TTKT-S70	ANSI/DIN Flange, PTFE Diaphragm, PTFE Ball, PVDF Seat, PTFE O-Ring, Stainless Steel Hardware

*Pump model is part of the Ready2Ship Program