

SPECIFICATIONS SHEET

A100 – 1 in. Metal PUMP



Air Inlet
1/4" FNPT

Liquid Inlet
1"

Liquid Discharge
1"

Connection Type
FNPT/FBSPT (Threaded)

Max Suction Lift Capability
17 ft-H₂O (5.2 m-H₂O) Dry
30 ft-H₂O (9.1 m-H₂O) Wet

Max Flow Rate
48 gpm (182 lpm)

Max Pressure
120 psi (8.2 bar)

Max Solids Dia.
1/4" (6.4 mm)

Disp. Per Stroke
0.07 gal (0.28 L)

Weight
Al: 18 lbs (8 kg)
SS: 38 lbs (17 kg)

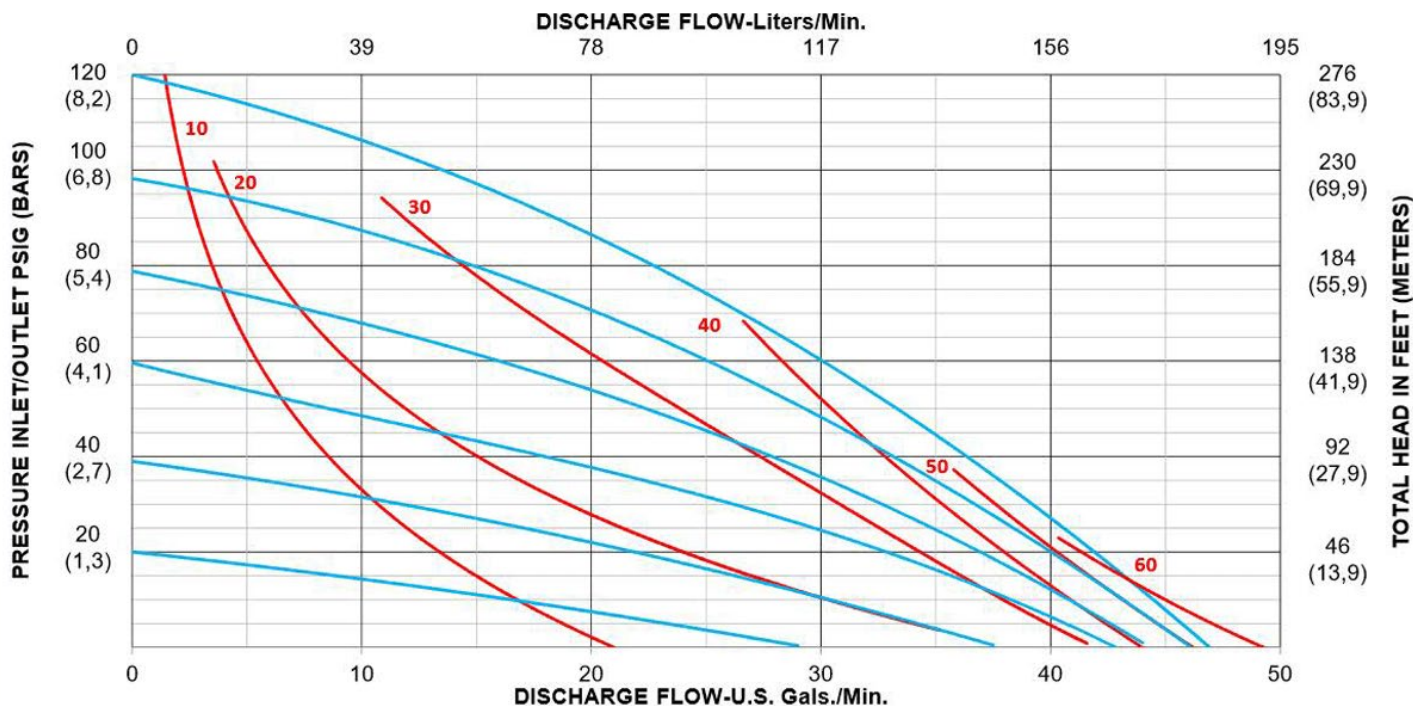

PSG
All-Flo
22069 Van Buren Street
Grand Terrace, CA 92313, USA

P: +1 (440) 354-1700
F: +1 (440) 354-9466

all-flo.com



SPECIFICATIONS SHEET

A100 – 1 in. Metal PUMP

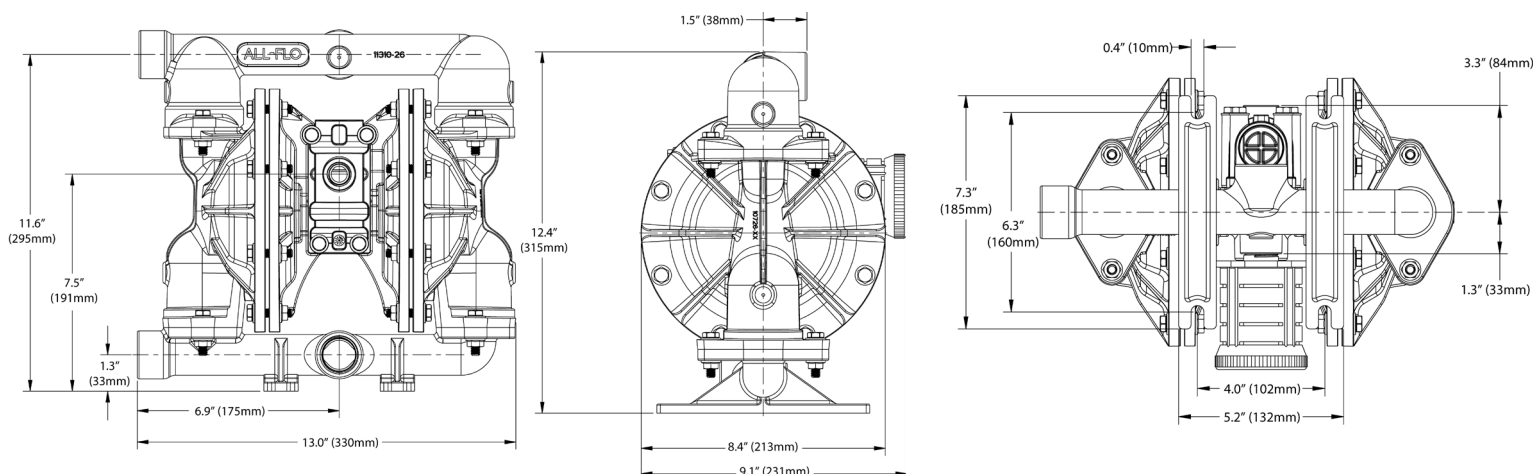

Construction

Wet End:	Aluminum, Anodized Aluminum
Air End:	Aluminum
Diaphragms:	Bunast™, PTFE, Santoprene®, Buna-N, FKM
Balls:	Bunast™, PTFE, Santoprene®, Buna-N, FKM
Seats:	Aluminum, Stainless Steel, Polypropylene, Nylon
O-Rings:	Buna-N, EPDM, PTFE, FKM
Hardware:	Zinc Plated Steel, Stainless Steel
Muffler:	Plastic, Metal

Popular Models

A100-NAA-GNPN-B30	NPT, Bunast™ Diaphragm, Bunast™ Ball, Polypropylene Seat, Buna-N O-Ring, Zinc Plated Hardware
A100-NAA-SSPE-B30*	NPT, Santoprene® Diaphragm, Santoprene® Ball, Polypropylene Seat, EPDM O-Ring, Zinc Plated Hardware
A100-NAA-TTYT-B30*	NPT, PTFE Diaphragm, PTFE Ball, Polypropylene Seat, FKM O-Ring, Zinc Plated Hardware
A100-NAA-HNPN-B30	NPT, Santoprene® Diaphragm, Santoprene® Ball, PVDF Seat, EPDM O-Ring, Stainless Steel Hardware

*Pump model is part of the Ready2Ship program



PSG
All-Flo
22069 Van Buren Street
Grand Terrace, CA 92313, USA

P: +1 (440) 354-1700
F: +1 (440) 354-9466

all-flo.com

