

SPECIFICATIONS SHEET

A075 – 3/4 in. PLASTIC PUMP



Air Inlet
1/4" FNPT

Liquid Inlet
3/4"

Liquid Discharge
3/4"

Connection Type
FNPT/FBSPT (Threaded)

Max Suction Lift Capability
15 ft-H₂O (4.6 m-H₂O) Dry
26 ft-H₂O (7.9 m-H₂O) Wet

Max Flow Rate
17 gpm (64.6 lpm)

Max Pressure
120 psi (8.2 bar)

Max Solids Dia.
1/8" (3.2 mm)

Disp. Per Stroke
0.03 gal (0.10 L)

Weight
Poly: 9 lbs (4.1 kg)
PVDF: 12 lbs (5.4 kg)
Nylon: 12 lbs (5.4 kg)

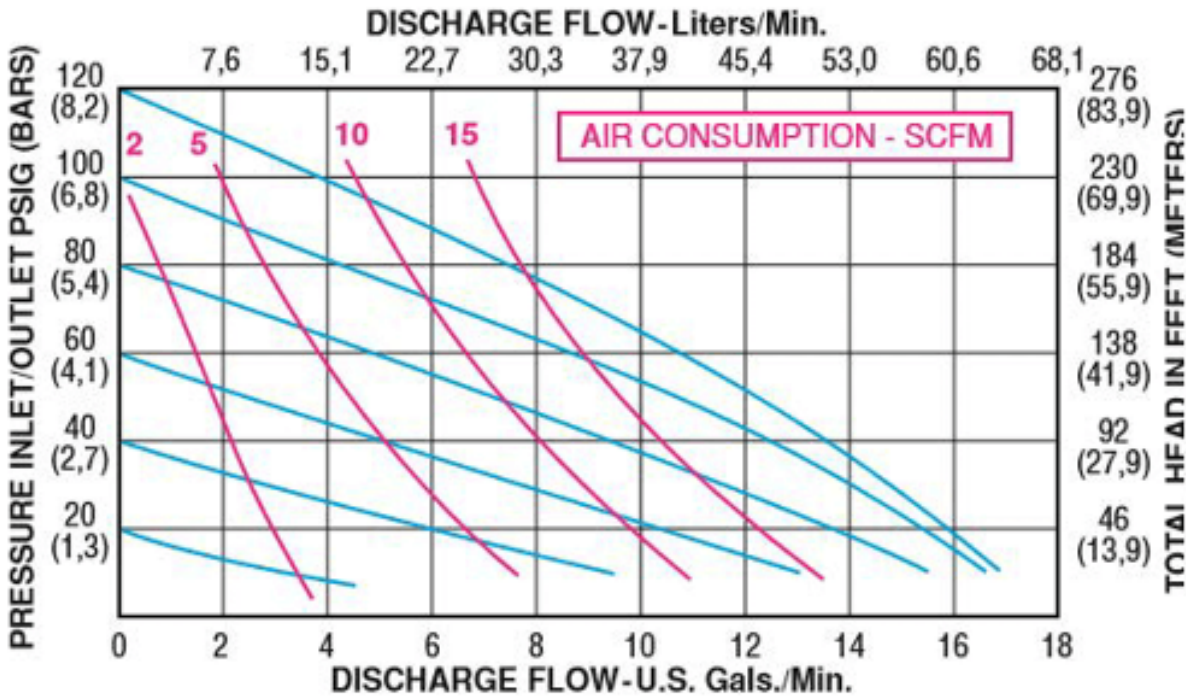

PSG
All-Flo
22069 Van Buren Street
Grand Terrace, CA 92313, USA

P: +1 (440) 354-1700
F: +1 (440) 354-9466

all-flo.com



SPECIFICATIONS SHEET

A075 – 3/4 in. PLASTIC PUMP

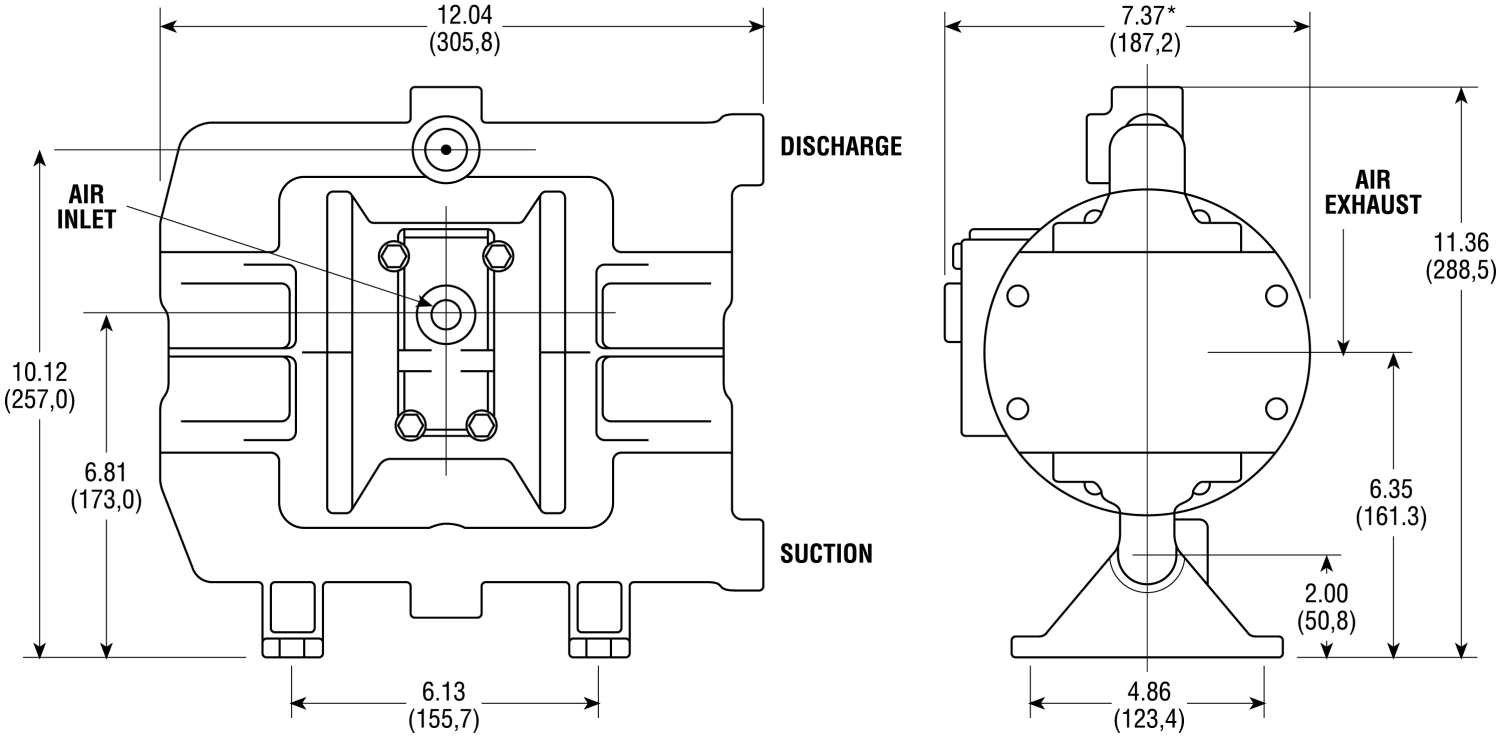

Construction

Wet End:	Polypropylene, PVDF, Conductive Nylon
Air End:	Glass Filled Polypropylene
Diaphragms:	Bunast™, PTFE, Santoprene®, FKM
Balls:	Bunast™, PTFE, Santoprene®, FKM
Seats:	Polypropylene, PVDF
O-Rings:	Buna-N, EPDM, PTFE, FKM
Hardware:	PTFE Coated Stainless Steel, Stainless Steel
Muffler:	Plastic, Metal

Popular Models

A075-NPP-GGPN-S70	NPT(BSP), Bunast™ Diaphragm, Bunast™ Ball, Polypropylene Seat, Buna-N O-Ring, Stainless Steel Hardware
A075-NPP-SSPE-S70	NPT(BSP), Santoprene® Diaphragm, Santoprene® Ball, Polypropylene Seat, EPDM O-Ring, Stainless Steel Hardware
A075-NPP-TTPT-S70	NPT(BSP), PTFE Diaphragm, PTFE Ball, Polypropylene Seat, FKM O-Ring, Stainless Steel Hardware
A075-NPK-SSKE-S70	NPT(BSP), Santoprene® Diaphragm, Santoprene® Ball, PVDF Seat, EPDM O-Ring, Stainless Steel Hardware
A075-NPK-TTKT-S70	NPT(BSP), PTFE Diaphragm, PTFE Ball, PVDF Seat, PTFE O-Ring, Stainless Steel Hardware



PSG
 All-Flo
 22069 Van Buren Street
 Grand Terrace, CA 92313, USA

P: +1 (440) 354-1700
 F: +1 (440) 354-9466

all-flo.com

