

SPECIFICATIONS SHEET

A050 – 1/2 in. PLASTIC PUMP

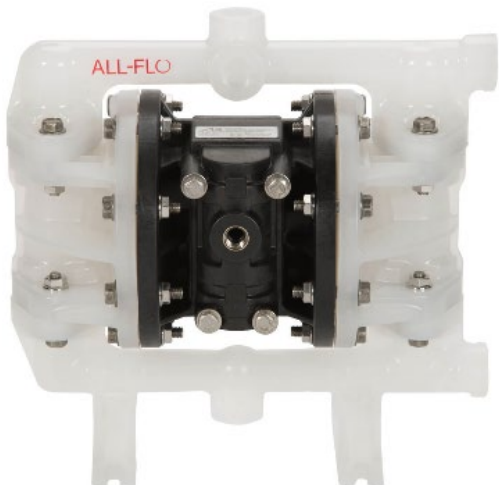

Air Inlet
1/4" FNPT

Liquid Inlet
1/2"

Liquid Discharge
1/2"

Connection Type
FNPT/FBSPT (Threaded)

Max Suction Lift Capability
15 ft-H₂O (4.6 m-H₂O) Dry
26 ft-H₂O (7.9 m-H₂O) Wet

Max Flow Rate
17 gpm (64.6 lpm)

Max Pressure
120 psi (8.2 bar)

Max Solids Dia.
1/8" (3.2 mm)

Disp. Per Stroke
0.03 gal (0.04 L)

Weight
Poly: 9 lbs (4.1 kg)
PVDF: 12 lbs (5.4 kg)
Nylon: 12 lbs (5.4 kg)

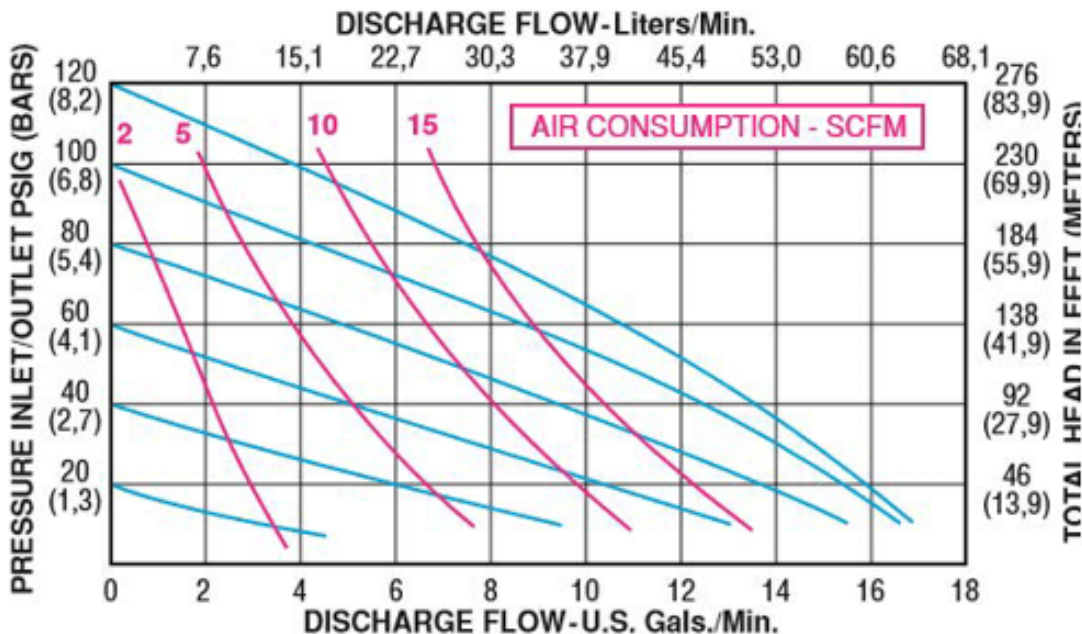

SPECIFICATIONS SHEET

A050 – 1/2 in. PLASTIC PUMP

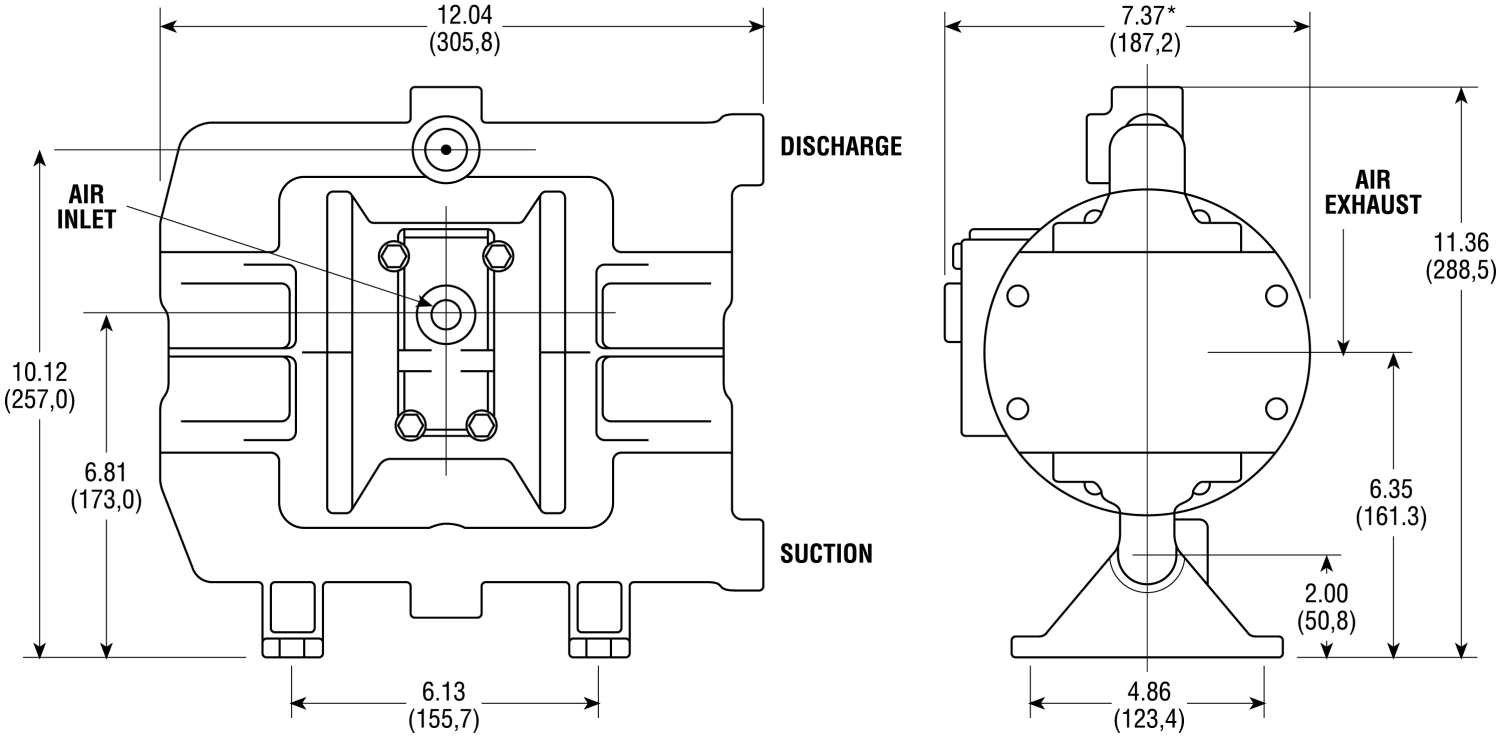

Construction	
Wet End:	Polypropylene, PVDF, Conductive Nylon
Air End:	Glass Filled Polypropylene
Diaphragms:	Bunast™, PTFE, Santoprene®, FKM
Balls:	Bunast™, PTFE, Santoprene®, FKM
Seats:	Polypropylene, PVDF, Nylon
O-Rings:	Buna-N, EPDM, PTFE, FKM
Hardware:	PTFE Coated Stainless Steel, Stainless Steel
Muffler:	Plastic, Metal

Popular Models	
A050-SPP-GGPN-S70*	Polypropylene, NPT(BSP), Bunast™ Diaphragm, Bunast™ Ball, Polypropylene Seat, Buna-N O-Ring, Stainless Steel Hardware
A050-SPP-SSPE-S70*	Polypropylene, NPT(BSP), Santoprene® Diaphragm, Santoprene® Ball, Polypropylene Seat, EPDM O-Ring, Stainless Steel Hardware
A050-SPP-TTPV-S70*	Polypropylene, NPT(BSP), PTFE Diaphragm, PTFE Ball, Polypropylene Seat, FKM O-Ring, Stainless Steel Hardware
A050-SPK-SSKE-S70	PVDF, NPT(BSP), Santoprene® Diaphragm, Santoprene® Ball, PVDF Seat, EPDM O-Ring, Stainless Steel Hardware
A050-SPK-TTKT-S70	PVDF, NPT(BSP), PTFE Diaphragm, PTFE Ball, PVDF Seat, PTFE O-Ring, Stainless Steel Hardware

*Pump model is part of the Ready2Ship Program



PSG
All-Flo
22069 Van Buren Street
Grand Terrace, CA 92313, USA

P: +1 (440) 354-1700
F: +1 (440) 354-9466

all-flo.com

