

PUMPS

HD25 - HD32 - HD40 - HDX40

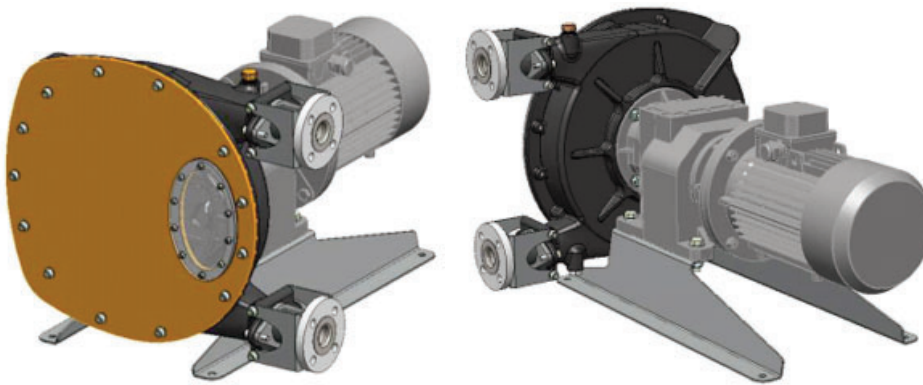

Installation
Operation
Maintenance

EC CERTIFICATE OF CONFORMITY :

The EC Certificate of Conformity (paper version) is systematically attached to the equipment when shipped.

WARRANTY :

ABAQUE pumps are covered 24 months by warranty within the limits mentioned in our General Sales Conditions. In case of a use other than that mentioned in the Instructions manual, and without preliminary agreement of ABAQUE, warranty will be canceled.

PATENTS :

For relevant patents on this product refer to : www.psgdover.com/abaque/support/patents



Z.I. La Plaine des Isles - F 89000 AUXERRE - FRANCE
Tél. : +33 (0)3.86.49.86.30
contact.abaque@psgdover.com • www.psgdover.com/abaque

Your distributor :

ABAQUE PERISTALTIC HOSE PUMPS

SAFETY INSTRUCTIONS, STORAGE, INSTALLATION AND MAINTENANCE

Definition of safety symbols



This is a SAFETY ALERT SYMBOL.

When you see this symbol on the product, or in the manual, look for one of the following signal words and be alert to the potential for personal injury, death or major property damage.



Warns of hazards that WILL cause serious personal injury, death or major property damage.



Warns of hazards that CAN cause serious personal injury, death or major property damage.



Warns of hazards that CAN cause personal injury or property damage.

NOTICE

Indicates special instructions which are very important and must be followed.

TABLE OF CONTENTS

Page

1. INSTALLATION	4
1.1 Operating principle	4
1.2 Hose compression	4
1.3 Pumped liquid	4
1.4 Piping installation	4
1.5 Rotation direction	5
1.6 Highly solid loaded liquids	5
1.7 Operation with vacuum on suction	6
1.8 Lifting	6
1.9 Pump location	6
1.10 Anchoring the pump	6
1.11 Electric motors	6
2. SETTING THE HOSE COMPRESSION	7
2.1 Setting the hose compression	7
2.2 How to use the setting tables	7
2.3 Setting tables	7
3. OPERATION	10
3.1 Pump storage	10
3.2 Hose storage	10
3.3 Hot liquids pumping	10
3.4 Pump stopped with liquid inside	10
3.5 Starting the pump	10
3.6 Stopping the pump	10
3.7 Hose burst	10
3.8 Scrapping	10
4. MAINTENANCE	11
4.1 Lubricant replacement	12
4.2 Hose replacement	12
4.3 Rotor assembly removal	15
4.4 Shaft seal replacement	17
4.5 Shoes replacement	19
4.6 Pump pressure setting	20
5. TROUBLESHOOTING	21
6. TECHNICAL SPECIFICATIONS	22
7. OVERALL DIMENSIONS	34

TECHNICAL CHARACTERISTICS

NOTES

The ABAQUE peristaltic pumps **MUST** be installed on systems specially designed by qualified staff. Installation **MUST** comply with local standards, national rules and safety regulations.

This manual is designed for installation and start-up of the peristaltic pumps. It **MUST** be supplied with the pump.

Maintenance of the peristaltic pumps must be carried out **ONLY** by qualified personnel. This operation must comply with local and national regulations as well as safety standards.

Read the whole manual and all the instructions and precautions, **BEFORE** using any ABAQUE pumps.

Do not remove any warning and use stickers from the pumps.

NOTES

The numbers after part names correspond to reference numbers in the spare parts lists.

Photos and drawings used in this IOM are not contractual.

TECHNICAL CHARACTERISTICS		HD25	HD32	HD40	HDX40
Maximum flowrate	Intermittent service	2,67 m ³ /h (11,76 GPM)	5,3 m ³ /h (23,34 GPM)	7,2 m ³ /h (31,7 GPM)	9,6 m ³ /h (42,27 GPM)
	Continuous service	1,67 m ³ /h (7,35 GPM)	3,2 m ³ /h (14,09 GPM)	4,65 m ³ /h (20,47 GPM)	6,4 m ³ /h (28,18 GPM)
Minimum rotation speed : This ensures good lubrication of the hose.		10 rpm			
Maximum rotation speed	Intermittent service	160 rpm	140 rpm	140 rpm	120 rpm
	Continuous service	100 rpm	85 rpm	85 rpm	70 rpm
Maximum running temperature	Hose NR - NBR - NBR FDA - Hypalon	70°C (158°F)			
	Hose EPDM	80°C (176°F)			
Minimum running temperature		0°C (32°F)			
Maximum pressure		15 bar (217 psi)			
Maximum viscosity		22 000 cP	17 000 cP	28 000 cP	23 000 cP

1. INSTALLATION

1.1 Operating principle

The pump operates by alternating contraction and relaxation of a specially designed elastomeric hose.

Two shoes attached 180° apart to a central rotor compress the hose against the pump body in a fluid tight manner.

Rotation of the rotor causes a flow by displacing the product into the hose. The pump body is filled with a special lubricant allowing shoes to slide easily over the hose, which avoids overheating.

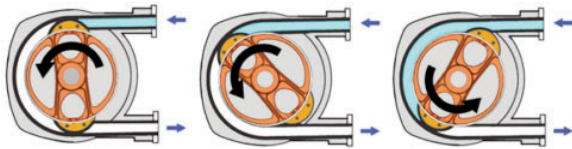

1.2 Hose compression

Performance and durability of the hose are guaranteed by inserting an adequate number of shims under the two shoes (see § PUMP PRESSURE SETTING).

1.3 Pumped liquid

Under normal operation, the pumped liquid is only in contact with the hose and the inserts. Chemical compatibility between pumped liquid and these two parts must therefore be carefully checked.

Five different quality elastomeric hoses are available :

- NR (natural rubber)
- NBR (perbunan or buna)
- NBR FDA (food perbunan or buna)
- EPDM
- Hypalon



Inserts are available in AISI 316 stainless steel, in polypropylene (PPH) and in polyfluoride vinylidene (PVDF).



This pumping technology is specially adapted to handle abrasive and solid loaded liquids.

During the compression stage, abrasive particles may penetrate the hose wall without damaging it. Immediately after, these particles are released into the liquid (the size of particles does not however have to exceed 15 % of the internal diameter of the hose).

You can contact our Technical Services at any time to ask for the information you require.

1.4 Piping installation

 WARNING	<p>FAILURE TO RELIEVE THE SYSTEM PRESSURE PRIOR TO PERFORMING ANY WORK ON THE PUMP OR THE INSTALLATION CAN CAUSE PERSONAL INJURY OR PROPERTY DAMAGE.</p>
 <p>Hazardous pressure can cause personal injury or property damage.</p>	

-  Not recommended
-  To be avoided if possible
-  Preferable

Make suction line as short and straight as possible.

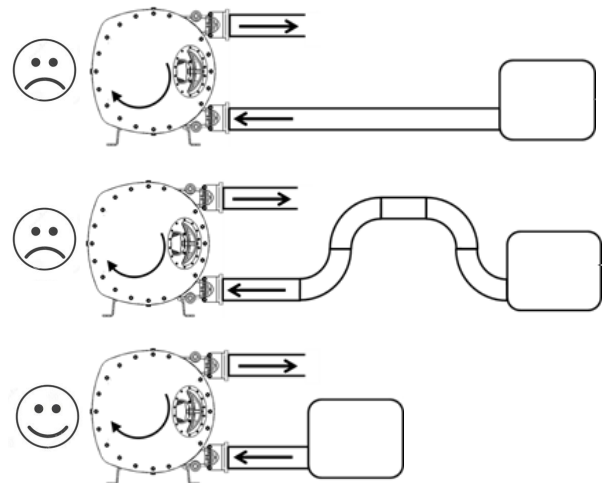

Avoid multiplying pipe bends.

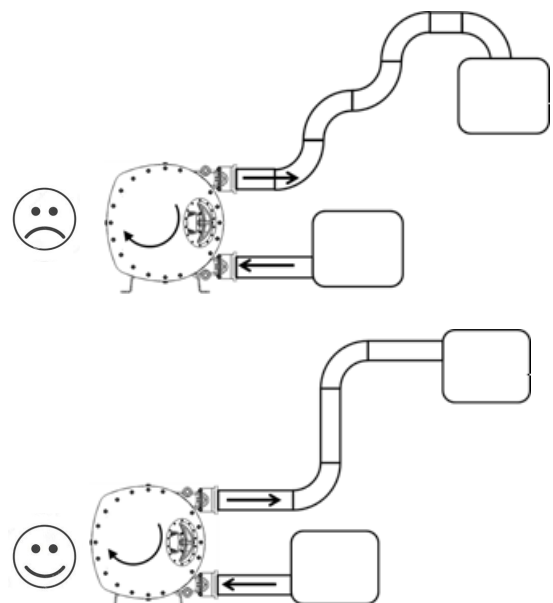

1. INSTALLATION (continued)

Use of a dead-end pulsation dampener

To obtain a maximum efficiency of the dampener, it should be placed as close as possible to pump port, and with inlet port facing full flow rather than being on a T junction.

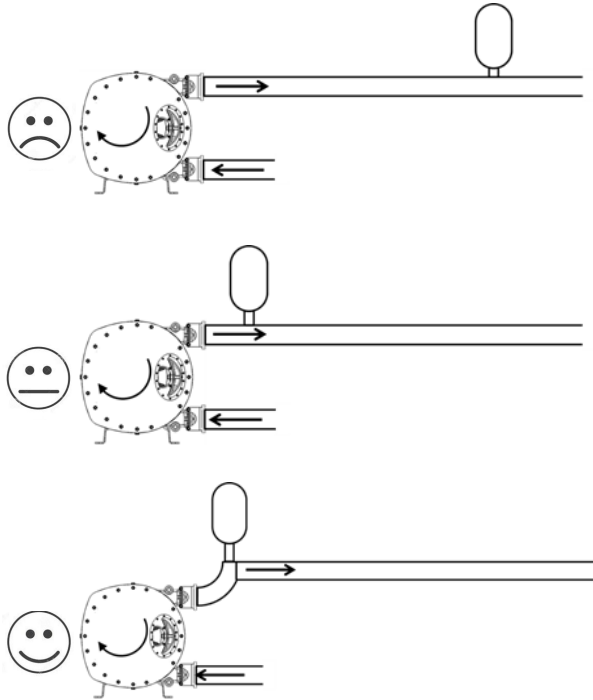

Use of an in-line pulsation dampener

To obtain a maximum efficiency of the dampener, it should be placed as close as possible to pump port.

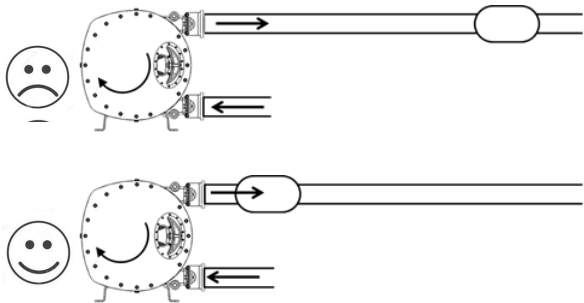

Change pumping set or pump ports position rather than multiplying pipe bends.

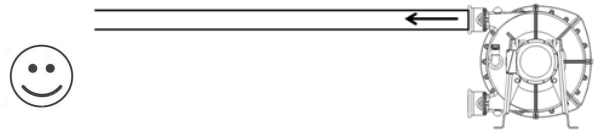
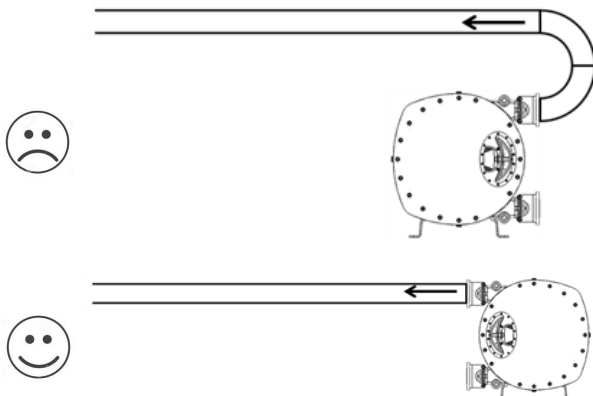

For hoses fitting on pump suction or discharge, a hose whip restrain device must be installed to limit the whip or travel of the pressurized hose at start up, or in case the hose breaks free.

WARNING: SEVERE PERSONAL INJURY OR PROPERTY DAMAGE CAN CAUSE FROM WHIPPING HOSES.

1.5 Rotation direction

<p>WARNING</p>	
<p>Hazardous pressure can cause personal injury or property damage.</p>	<p>FAILURE TO RELIEVE THE SYSTEM PRESSURE PRIOR TO PERFORMING ANY WORK ON THE PUMP OR THE INSTALLATION CAN CAUSE PERSONAL INJURY OR PROPERTY DAMAGE.</p>

The ABAQUE pump is reversible; this allows it to always circulate the liquid in the desired direction by choosing the corresponding direction of rotation.

The intake and discharge sides are determined as follows : When an observer is placed on pump cover side (opposite to the shaft output), if rotation takes place clockwise, the intake is on the bottom, on the contrary if the rotation is anticlockwise, the intake is on the top.

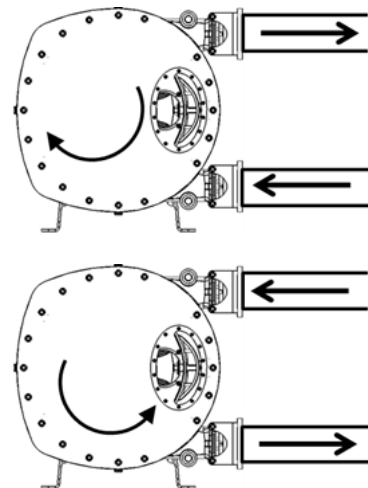

1.6 Highly solid loaded liquids

In the case where the pumped fluid contains particles, use the upper flange as the inlet flange.

This facilitates discharge of the sediments formed by the build-up of the particles contained in the fluid, so this reduces friction between the hose and the shoes. Therefore, the pump may be re-started more easily.

1. INSTALLATION (continued)

1.7 Operation with vacuum on suction

Because of the operating principle of the pump, using it with suction pressure lower than the atmospheric pressure will cause a resulting loss of flow more or less in line with the conditions of the application (hose material, rotation speed, temperature, etc.).

In order for the pump to generate the normally required flow, ABAQUE recommends using a vacuum draw kit inside the body of the pump.

In all cases, when using a vacuum kit, suction pressure must not be lower than -0,9 barg (-13 psig).

If a vacuum draw kit is not used on an ABAQUE pump operating with suction pressure lower than atmospheric pressure, ABAQUE no longer guarantees the performance of the pump.

1.8 Lifting

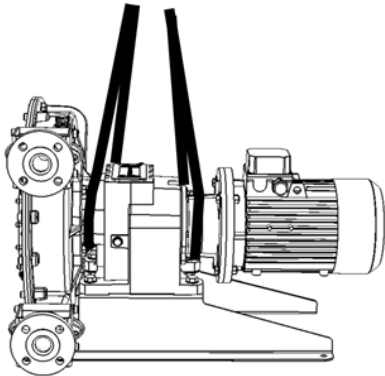

PRECAUTION

USE SUITABLE LIFTING DEVICES FOR HANDLING.

Pass a strap between pump body and gear reducer. Pass another one between gear reducer and motor and put all straps on a common hook.

Maximum pump weight : see § OVERALL DIMENSIONS.

1.9 Pump location

Provide sufficient clearance around the pump for maintenance operations.

Particularly, make sure that there is sufficient clearance for replacing the hose; the distance between the pump flanges and the closest obstacle must allow the hose to be removed, as shown below :

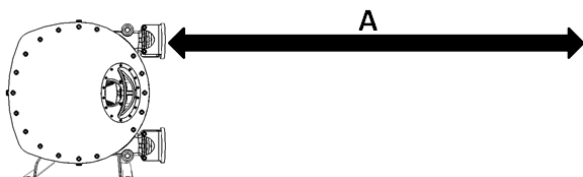

Distance A : 1200 mm (47,25 in.)

1.10 Anchoring the pump

The correct seating of the pump is vital for its efficient operation and its longevity.

The surface must be resistant enough to absorb the stresses due to the pump unit without deformation.

In the case where the unit is fastened by anchor lugs or bolts, it must be carefully wedged to prevent any deformation of the chassis when tightening the bolts.

1.11 Electric motors

	WARNING
	<p>DISCONNECT THE ELECTRICITY SUPPLY BEFORE ANY MAINTENANCE OPERATION.</p>
<p>Dangerous voltage. Can cause injury and death.</p>	

Check that the supply voltage matches the indications on the motor rating plate.

Comply with the wiring diagram, make sure the wires are rated for the power and take care with the contacts which must be thoroughly tightened.

The motors must be protected by appropriate circuit breakers and fuses. Connect the regulatory ground connections.

Check the direction of rotation :

	WARNING
	<p>OPERATION WITHOUT THE SHAFT PROTECTOR CAN CAUSE SERIOUS PERSONAL INJURY, MAJOR PROPERTY DAMAGE OR DEATH.</p>
<p>Do not operate without guard in place.</p>	

This fundamental checking of the pump must be done without any product, with the inlet and outlet circuit open to the air, for example, to avoid any risk of an unexpected pressure rise. Start the pump empty to check the correct operation of the connections and check that the direction of rotation corresponds to installation's inlet and outlet direction.

Follow the instructions below if necessary to change the direction of rotation :

- **Three phase motor** : switch any two wires of the current supply.
- **Two phase motor** : switch the two wires of the same phase.
- **Single phase motor** : comply with the instructions of the manual supplied with the motor.

2. SETTING THE HOSE COMPRESSION

In order to maintain the flow, to compensate for the tolerances of the assembly parts and to avoid premature wear of the hoses, it is necessary to adapt the crushing of the hose according to the rotation speed, the service pressure desired and the temperature.

2.1 Setting the hose compression

Thus, pumps assembled in the factory or outside the factory, have to be set in the following manner :

2.1.1 Reference shimming

This step is a mandatory step. The shims should not be removed unless the body or wheel is being replaced.

Reference shimming is performed to compensate for the tolerances of the assembly parts. Whatever the desired pump discharge pressure, the reference shimming is first carried out. It is done using fixed shims.

The distance 'a' is the gap between the top of the shoe and the hole of the pump's body must be within the reference shimming interval : see § SETTING TABLES - REFERENCE SHIMMING.

2.1.2 Final shimming at 5 bar

The number of removable shims to add is indicated § SETTING TABLES - FINAL SHIMMING AT 5 BAR taking into consideration pressure, speed and temperature. In the absence of precision on the desired pressure, the pumps delivered assembled (with motor and reducer) are set according to the reference shimming (5 bar).

2.2 How to use the setting tables

Too little hose compression leads to internal leaks which lead to rapid deterioration of the inside of the hose.

Too much hose compression puts significant internal strain on the pump as well as leading to abnormal overheating of the hose which greatly reduces its operational life.

NOTE

There must be the same number of shims under each shoe.

1. Choice of pump size in the reference shimming table : the distance must be within the interval thanks to the fixed shims : see § SETTING TABLES - REFERENCE SHIMMING.
2. Depending on the pressure, the desired speed and the temperature of the pumped product, add the number of removable shims : see § SETTING TABLES - FINAL SHIMMING AT 5 BAR.

2.3 Setting tables

The distance 'a' is the gap between the top of the shoe and the internal diameter of the pump body.

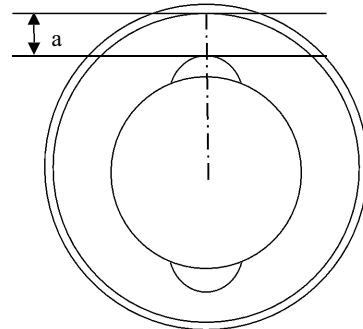

Removable shims are shaped like this :

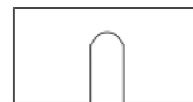

Fixed shims are shaped like this :

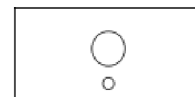

2. SETTING THE HOSE COMPRESSION (continued)

2.3.1 Reference shimming (fixed shims)

Pump	Reference shimming - mm (inch)
HD25	26,1 (1,028") < a ≤ 26,6 (1,047")
HD32	28,1 (1,106") < a ≤ 28,6 (1,126")
HD40	23,4 (0,921") < a ≤ 23,9 (0,941")
HDX40	25,0 (0,984") < a ≤ 25,5 (1,004")

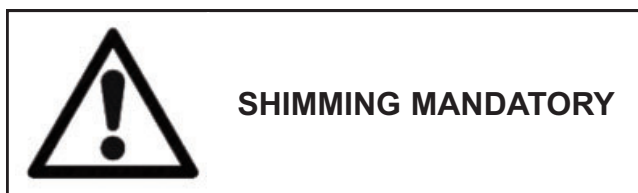

2.3.2 Final shimming at 5 bar (removable shims)

HD25			
bar (psi)	tr/min (rpm)	Abaque shimming	mm (inch)
$\Delta P \leq 5$ (72,5)	$5 < \Omega \leq 40$	+ 1 removable shim	$25,6$ (1,008") < a ≤ $26,1$ (1,028")
	$40 < \Omega \leq 160$	Reference shimming (fixed shims)	$26,1$ (1,028") < a ≤ $26,6$ (1,047")
5 (72,5) < $\Delta P \leq 7,5$ (108,75)	$5 < \Omega \leq 40$	+ 2 removable shims	$25,1$ (0,988") < a ≤ $25,6$ (1,008")
	$40 < \Omega \leq 120$	+ 1 removable shim	$25,6$ (1,008") < a ≤ $26,1$ (1,028")
	$120 < \Omega \leq 135$	Reference shimming (fixed shims)	$26,1$ (1,028") < a ≤ $26,6$ (1,047")
$7,5$ (108,75) < $\Delta P \leq 10$ (145)	$5 < \Omega \leq 40$	+ 3 removable shims	$24,6$ (0,969") < a ≤ $25,1$ (0,988")
	$40 < \Omega \leq 115$	+ 2 removable shims	$25,1$ (0,988") < a ≤ $25,6$ (1,008")
10 (145) < $\Delta P \leq 15$ (217,5)	$5 < \Omega \leq 40$	+ 4 removable shims	$24,1$ (0,949") < a ≤ $24,6$ (0,969")
	$40 < \Omega \leq 90$	+ 3 removable shims	$24,6$ (0,969") < a ≤ $25,1$ (0,988")
T° > 60° C (140°F) : remove one removable shim			

HD32			
bar (psi)	tr/min (rpm)	Abaque shimming	mm (inch)
$\Delta P \leq 5$ (72,5)	$5 < \Omega \leq 45$	+ 1 removable shim	$27,6$ (1,087") < a ≤ $28,1$ (1,106")
	$45 < \Omega \leq 140$	Reference shimming (fixed shims)	$28,1$ (1,106") < a ≤ $28,6$ (1,126")
5 (72,5) < $\Delta P \leq 7,5$ (108,75)	$5 < \Omega \leq 45$	+ 2 removable shims	$27,1$ (1,067") < a ≤ $27,6$ (1,087")
	$45 < \Omega \leq 105$	+ 1 removable shim	$27,6$ (1,087") < a ≤ $28,1$ (1,106")
	$105 < \Omega \leq 115$	Reference shimming (fixed shims)	$28,1$ (1,106") < a ≤ $28,6$ (1,126")
$7,5$ (108,75) < $\Delta P \leq 10$ (145)	$5 < \Omega \leq 45$	+ 3 removable shims	$26,6$ (1,047") < a ≤ $27,1$ (1,067")
	$40 < \Omega \leq 100$	+ 2 removable shims	$27,1$ (1,067") < a ≤ $27,6$ (1,087")
10 (145) < $\Delta P \leq 15$ (217,5)	$5 < \Omega \leq 45$	+ 4 removable shims	$26,1$ (1,028") < a ≤ $26,6$ (1,047")
	$45 < \Omega \leq 75$	+ 3 removable shims	$26,6$ (1,047") < a ≤ $27,1$ (1,067")
T° > 60° C (140°F) : remove one removable shim			

2. SETTING THE HOSE COMPRESSION (continued)

HD40			
<i>bar (psi)</i>	<i>tr/min (rpm)</i>	<i>Abaque shimming</i>	<i>mm (inch)</i>
$\Delta P \leq 5$ (72,5)	$5 < \Omega \leq 45$	+ 1 removable shim	$22,9$ (0,902") $< a \leq 23,4$ (0,921")
	$45 < \Omega \leq 140$	Reference shimming (fixed shims)	$23,4$ (0,921") $< a \leq 23,9$ (0,941")
5 (72,5) $< \Delta P \leq 7,5$ (108,75)	$5 < \Omega \leq 45$	+ 2 removable shims	$22,4$ (0,882") $< a \leq 22,9$ (0,902")
	$45 < \Omega \leq 115$	+ 1 removable shim	$22,9$ (0,902") $< a \leq 23,4$ (0,921")
$7,5$ (108,75) $< \Delta P \leq 10$ (145)	$5 < \Omega \leq 45$	+ 3 removable shims	$21,9$ (0,862") $< a \leq 22,4$ (0,882")
	$45 < \Omega \leq 100$	+ 2 removable shims	$22,4$ (0,882") $< a \leq 22,9$ (0,902")
10 (145) $< \Delta P \leq 15$ (217,5)	$5 < \Omega \leq 45$	+ 4 removable shims	$21,4$ (0,843") $< a \leq 21,9$ (0,862")
	$45 < \Omega \leq 75$	+ 3 removable shims	$21,9$ (0,862") $< a \leq 22,4$ (0,882")
T° > 60° C (140°F) : remove one removable shim			

HDX40			
<i>bar (psi)</i>	<i>tr/min (rpm)</i>	<i>Abaque shimming</i>	<i>mm (inch)</i>
$\Delta P \leq 5$ (72,5)	$5 < \Omega \leq 55$	+ 1 removable shim	$24,5$ (0,965") $< a \leq 25$ (0,984")
	$55 < \Omega \leq 120$	Reference shimming (fixed shims)	25 (0,984") $< a \leq 25,5$ (1,004")
5 (72,5) $< \Delta P \leq 7,5$ (108,75)	$5 < \Omega \leq 55$	+ 2 removable shims	24 (0,945") $< a \leq 24,5$ (0,965")
	$55 < \Omega \leq 100$	+ 1 removable shim	$24,5$ (0,965") $< a \leq 25$ (0,984")
$7,5$ (108,75) $< \Delta P \leq 10$ (145)	$5 < \Omega \leq 55$	+ 3 removable shims	$23,5$ (0,925") $< a \leq 24$ (0,945")
	$55 < \Omega \leq 85$	+ 2 removable shims	24 (0,945") $< a \leq 24,5$ (0,965")
10 (145) $< \Delta P \leq 15$ (217,5)	$5 < \Omega \leq 55$	+ 4 removable shims	23 (0,906") $< a \leq 23,5$ (0,925")
	$55 < \Omega \leq 65$	+ 3 removable shims	$23,5$ (0,925") $< a \leq 24$ (0,945")
T° > 60° C (140°F) : remove one removable shim			

3. OPERATION

3.1 Pump storage

If the pump remains unused for more than 3 months, remove the hose or the shoes. If you do not wish to remove the hose or the shoes, operate the pump for 5 minutes once a week.

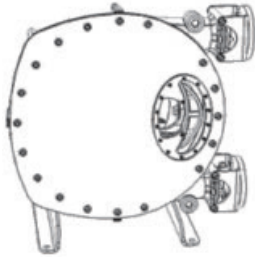

NOTE :

Check that the rotor is always in such a position that one of the shoes can be seen through the window.

For storage at temperatures below 0 °C (32 °F), specific precautions must be taken. See § LUBRICANT REPLACEMENT.

3.2 Hose storage

Hose shelf life is limited to two years from the date of purchase.

The hoses must be stored in a cool place protected from light. Exposure to ultraviolet rays accelerates deterioration of the material, thus reducing shelf life.

3.3 Hot liquids pumping

	CAUTION
	THE SURFACES OF THE PUMP CAN BE AT A TEMPERATURE LIABLE TO CAUSE INJURY OR SEVERE DAMAGE.
Excessive temperature- can cause injury or severe damage.	

When pumping products at high temperatures, take care when starting the pump for the first time, tighten the bolts to compensate for expansion effects.

If the temperature of the pumped product is greater than 60°C (140°F) : see NT 1101-Q00 SETTING HOSE COMPRESSION PUMPS HD.

3.4 Pump stopped with liquid inside

In the case where the pumping circuit is situated between isolating valves and/or has a check valve, you must bear in mind the variations in temperature that can occur, leading in particular to the expansion of the product in the circuit. In this case, provide a means of releasing the expansion volume. The use of a relief valve can suffice for this function. The opening pressure of this valve must be compatible with the pressure allowed by the parts composing the circuit. With products including particles that settle at shutdown, it is necessary to ensure that the consistency of the deposited products will not affect the start-up of the pump.

3.5 Starting the pump

	WARNING
	FAILURE TO RELIEVE THE SYSTEM PRESSURE PRIOR TO PERFORMING ANY WORK ON THE PUMP OR THE INSTALLATION CAN CAUSE PERSONAL INJURY OR PROPERTY DAMAGE.
Hazardous pressure can cause personal injury or property damage.	

	WARNING
	OPERATION WITHOUT THE SHAFT PROTECTOR CAN CAUSE SERIOUS PERSONAL INJURY, MAJOR PROPERTY DAMAGE OR DEATH.
Do not operate without guard in place.	

Before starting up the pump, always ensure that :

- Pump lubricant level is correct.
- The breathers on the rear of the pump and on the gearbox are free from any obstruction.
- The gearbox has been filled with oil and that the oil level is correct.
- All valves open on both suction and discharge lines.
- No other item is obstructing suction and discharge lines.

For use at temperatures below 0 °C (32 °F), specific precautions must be taken. See § LUBRICANT REPLACEMENT.

3.6 Stopping the pump

When stopping the pump, we recommend waiting for the pump to stop completely before closing any valve on both suction and discharge lines.

3.7 Hose burst

	WARNING
	• THE CASING MAY BE FILLED WITH THE PUMPED FLUID. • IF THE PUMP IS LOADED AT INTAKE OR DISCHARGE, ALL THE FLUID MAY BE EVACUATED THROUGH A HOLE IN THE HOSE IN THE PUMP BODY.
Hazardous pressure can cause personal injury or property damage.	

When the hose breaks, there is a risk that the lubricant may be contaminated by the pumped liquid.

3.8 Scrapping

The pump must be scrapped in compliance with applicable regulations. During this operation, particular care must be paid to the drainage stages of the pump (pumped product).

4. MAINTENANCE

	WARNING
DISCONNECT THE ELECTRICITY SUPPLY BEFORE ANY MAINTENANCE OPERATION.	
Dangerous voltage. Can cause injury and death.	

	WARNING
IF PUMPING HAZARDOUS OR TOXIC FLUIDS, THE SYSTEM MUST BE FLUSHED PRIOR TO PERFORMING ANY SERVICE OPERATION.	
Hazardous or toxic fluids can cause serious injury.	

	WARNING
HANDLING THE PUMP WITHOUT THE COVER IN PLACE MAY CAUSE BODILY HARM, SERIOUS INJURY OR EVEN DEATH.	
Do not operate without guard in place.	

	WARNING
HYDRAULIC PRESSURE MUST BE FULLY RELEASED BEFORE MAINTENANCE OPERATIONS IN ORDER TO PREVENT PERSONAL INJURY OR PROPERTY DAMAGE.	
Hazardous pressure can cause personal injury or property damage.	

Before proceeding to any maintenance operation, carefully check that :

- Pump has been drained from pumped liquid.
- There is no inside residual pressure left.
- Isolation valves are closed.
- Power supply is switched off and disconnected.

Suggested parts to order for each operation

Table below lists the minimum part list to have before each maintenance operation. Depending on their conditions, some other parts may also need replacement.

Lubricant replacement:

- Lubricant can

Hose replacement :

- Lubricant can
- 1 hose 16
- 2 gaskets 1105

Rotor assembly removal :

- Lubricant can
- 1 hose 16
- 2 gaskets 1105
- 1 cover gasket 10

Shaft seal replacement :

- Lubricant can
- 1 hose 16
- 2 gaskets 1105
- 1 cover gasket 10
- 1 shaft seal 26
- 1 friction ring 27

Shoes replacement :

- Lubricant can
- 2 shoes 5
- 2 to 6 removable shims 4
- 1 window seal 46

Pump pressure setting :

- Lubricant can
- 2 to 6 removable shims 4
- 1 window seal 46

Tightening torques (Nm)

Part No	Designation	HD25	HD32 HD40	HDX40
19	Rotor hub	17	17	41
28	Shoe screw	37	64	158
33	Cover screw	19	37	37
37	Window screw	3	3	3
42	Gear reducer / pump body nut	37	37	64
48	Bracket screw	19	37	37
61	Gear reducer / baseplate nut	64	101	158
1106	Pressing gland screw	15 ± 2	30 ± 4,5	30 ± 4,5

4. MAINTENANCE (continued)

4.1 Lubricant replacement

The hose is lubricated with a special mixture. ABAQUE lubricant is recommended to lengthen the service life of the hose.

It is recommended to change the lubricant when :

- Replacing the hose.
- After 2000 hours of operation.

The minimum working or storage temperature for the pump lubricant is 0°C (32°F).

For use / storage at lower ambient temperatures, it is necessary to add ethylene glycol to the ABAQUE lubricant. To maintain optimum lubrication, the volume of ethylene glycol should remain between 4% and 6% of the total volume of lubricant, and the total quantity of lubricant present in the pump must be in compliance with the value specified above. In any case, the ambient temperature should never be lower than -20°C (-4°F).

DO NOT USE ANY VEGETAL, MINERAL OR SYNTHETIC OIL AS IT WOULD RAPIDLY DESTROY THE HOSE.

Draining

Put a drain tray below plug 23.

Unscrew plug 23 and wait for complete lubricant draining. Clean and degrease plug 23.

Wrap it with PTFE tape.

Screw plug 23 in the pump body.

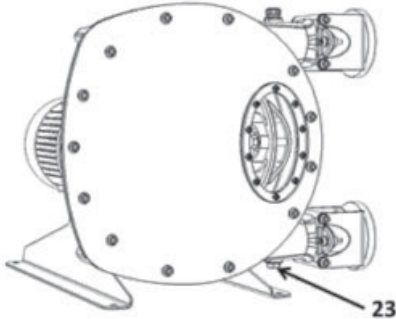

Lubricant filling

Remove breather 11.

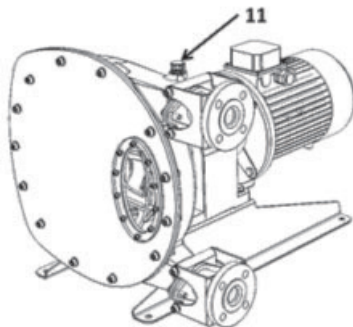

Fill the pump with corresponding volume of lubricant :

HD25	1,4 l. (0,37 gal.)
HD32 - HD40	2,5 l. (0,67 gal.)
HDX40	5,0 l. (1,32 gal.)

Put back breather 11.

4.2 Hose replacement

Hose removal

Drain lubricant (see § LUBRICANT REPLACEMENT). Disconnect suction and discharge ports.

Disconnect power supply.

Make sure there is enough space beside pump to let hose coming out. See § PUMP LOCATION.

Unscrew and remove pressing gland screws 1106 and their washers 1108.

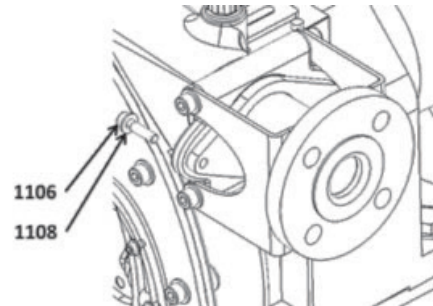

Loosen and remove hose clamp 9.

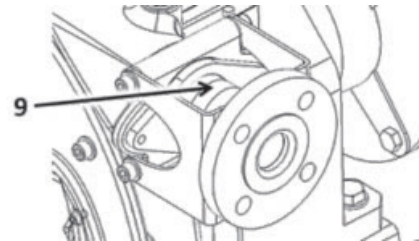

Remove insert 12 and flange 47.

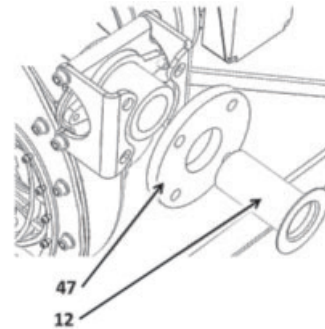

Remove the four screws 48 and washers 49. Remove the two brackets 18.

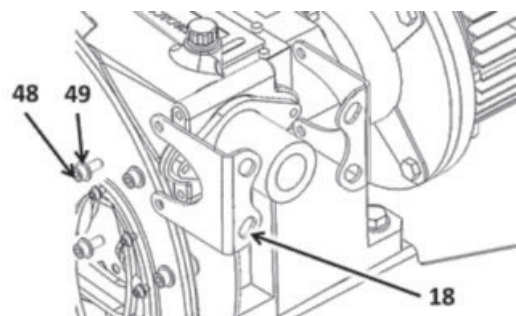

4. MAINTENANCE (continued)

Remove pressing gland 1104 and gasket 1105.

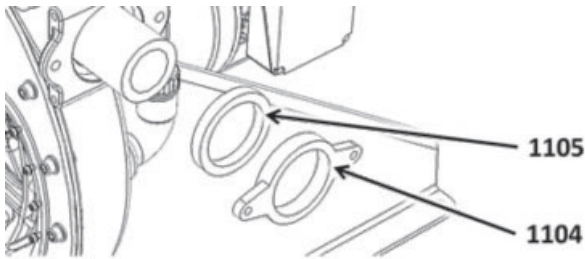

Put a drain tray under bottom port and repeat the same operations on bottom port.

	WARNING
	<p>THE HOSE CAN COME OUT OF PUMP VIOLENTLY. BE SURE NO ONE IS IN FRONT OF PUMP PORTS.</p>
<p>Hazardous machinery can cause severe personal injury or property damage.</p>	

Connect power supply.

Rotate the pump intermittently until the hose 16 is completely outside pump body.

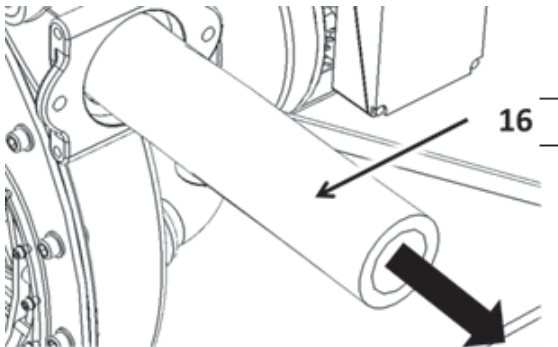

	WARNING
	<p>DISCONNECT THE ELECTRICITY SUPPLY BEFORE ANY MAINTENANCE OPERATION.</p>
<p>Dangerous voltage. Can cause injury and death.</p>	

Disconnect power supply.

Hose refitting

	WARNING
	<p>NEVER INSERT THE HOSE OR RUN THE PUMP WITHOUT ITS COVER AND ITS WINDOW IN PLACE.</p>
<p>Do not operate without guard in place.</p>	

Clean the hose 16 to eliminate any particles that may have adhered to it (gravel, etc.).

Generously coat the hose with lubricant.

Connect power supply.

Insert one end of the hose 16 in the suction port.

If pump rotates clockwise, suction is on the bottom port :

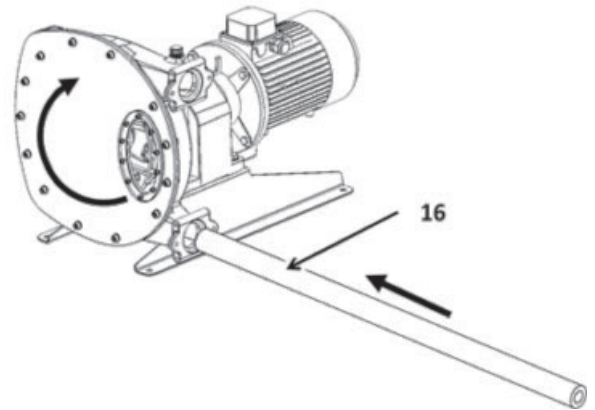

If pump rotates anti-clockwise, suction is on the top port :

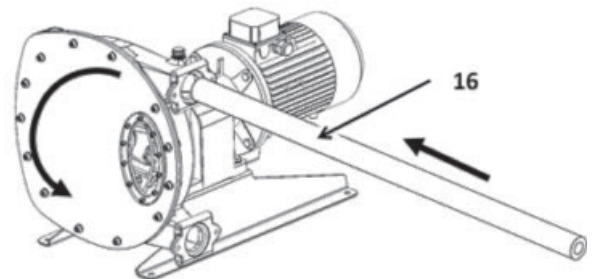

4. MAINTENANCE (continued)

Rotate the pump intermittently until the hose 16 is completely inserted in the body and show equal lengths outside the body on both ports :

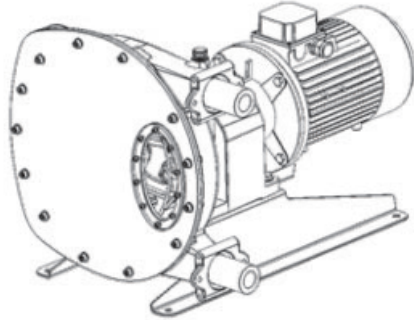

 WARNING	DISCONNECT THE ELECTRICITY SUPPLY BEFORE ANY MAINTENANCE OPERATION.
Dangerous voltage. Can cause injury and death.	

Disconnect power supply.

On one port :

1. Place gasket 1105 and pressing gland 1104.

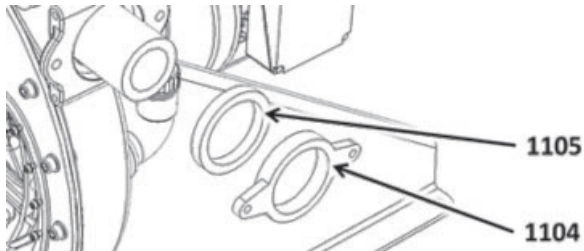

2. Place the two brackets 18. Screw and tighten the four screws 48 with their washers 49.

	HD25	HD32/40	HDX40
Tightening torque (Nm)	19	37	37

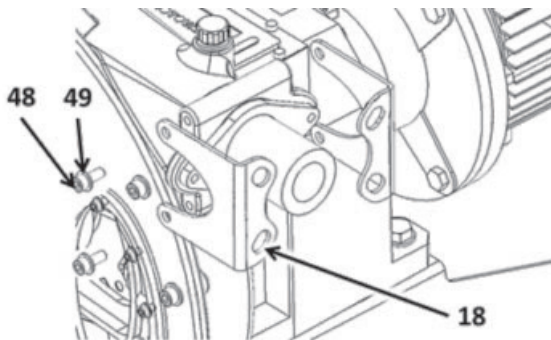

3. Place flange 47 and put insert 12 after coating its outside with pump lubricant.

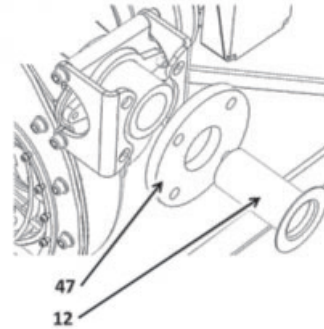

4. Fit and tighten hose clamp 9.

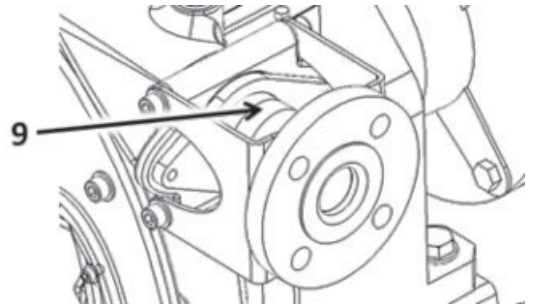

5. Fit screws 1106 with their washers and tighten them.

	HD25	HD32/40	HDX40
Tightening torque (Nm)	15 ± 2	30 ± 4,5	30 ± 4,5

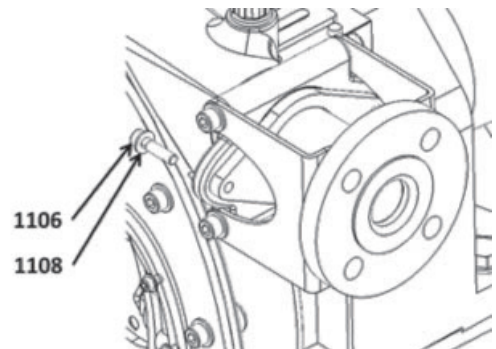

Repeat operations 1 to 5 on the other port.

Fill the pump with lubricant (see § LUBRICANT REPLACEMENT).

Connect power supply.

Rotate pump and check that there is no visible axial movement of the hose or lubricant leakage.

4. MAINTENANCE (continued)

4.3 Rotor assembly removal

Disassembly and reassembly of the rotor 3 are required when :

- replacing the shaft seal 26.
- performing a complete overhaul.
- disassembling or replacing the gear reducer.

Rotor assembly removal

Drain lubricant (see § LUBRICANT REPLACEMENT) and remove hose (see § HOSE REPLACEMENT).

Loosen screws 33 with their washers 34.

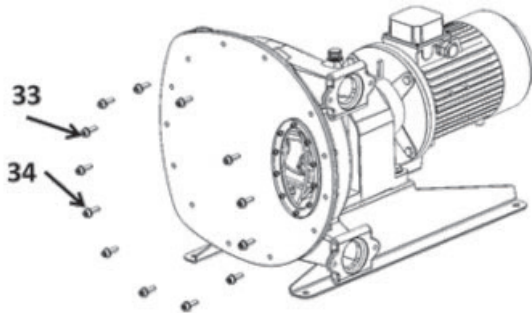

	WARNING
	BE CAREFUL WITH THE WEIGHT OF THE COVER WHEN ALL SCREWS ARE REMOVED.
<p>The weight of the parts can be dangerous and may provoke bodily injuries or material damages.</p>	

Remove cover 2 with its gasket 10.

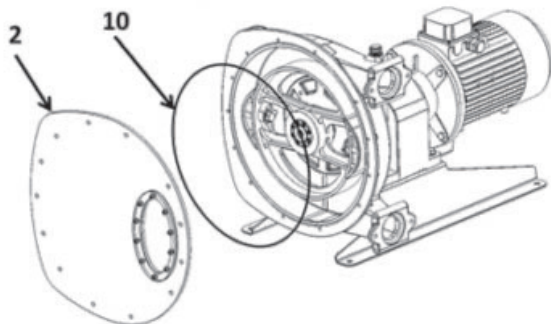

On the rotor 3, loosen screws 28 and remove them with washers 29. Remove shoes 5 and shims 4. Note shims type and quantity to restore identical shimming when reassembling the pump.

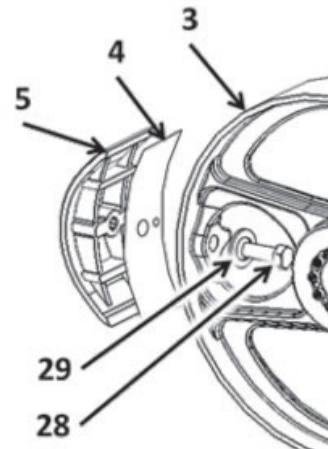

On rotor hub 19, loosen all screws without removing them. Put 5 screws in the extraction threading to loosen the hub.

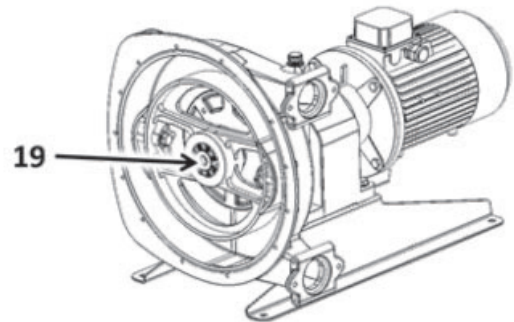

	WARNING
	BE CAREFUL WITH THE WEIGHT OF THE ROTOR.
<p>The weight of the parts can be dangerous and may provoke bodily injuries or material damages.</p>	

Pull out the rotor 3.

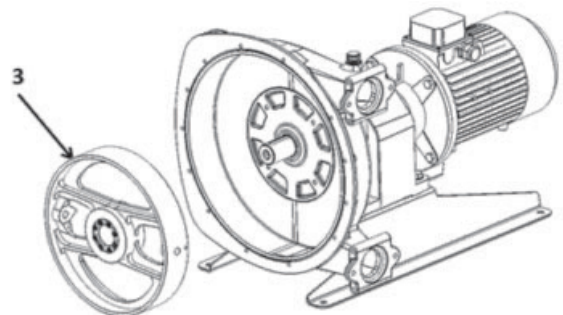

4. MAINTENANCE (continued)

Rotor assembly refitting

Place hub 19 and rotor 3 on gear reducer shaft.

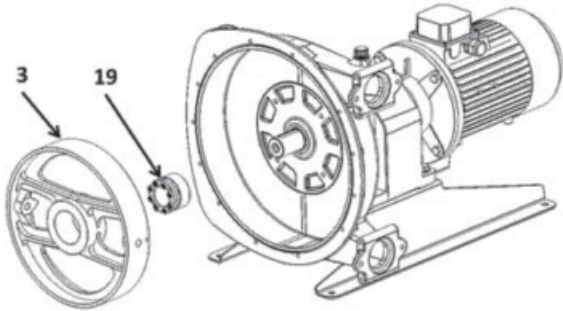

Position rotor 3 to have distance B between rotor outer edge and casing 1 back wall.

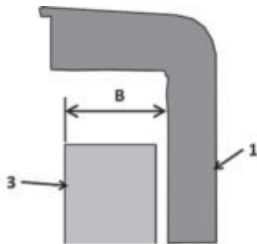

	HD25	HD32/40	HDX40
Distance B	60,5 ±1 mm (2,382 ± 0,039 in.)	74 ±1 mm (2,913 ± 0,039 in.)	80 ±1 mm (3,15 ± 0,039 in.)

Progressively tighten screws on hub 19, keeping distance B constant.

	HD25	HD32/40	HDX40
Tightening torque (Nm)	17	17	41

On rotor 3, place shoes 5 and shims 4. Make sure shims type and quantity are identical to combination found when taking pump apart. Screw and tighten screws 28 with their washers 29.

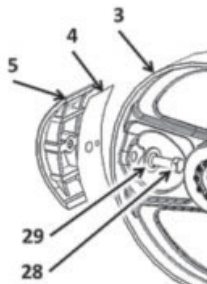

Screw and tighten screws 28 with their washers 29, carefully checking shoes 5 alignment with rotor 3.

	HD25	HD32/40	HDX40
Tightening torque (Nm)	37	64	158

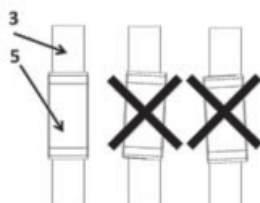

Rotate rotor and shoes assembly slowly and carefully check that no part comes in friction against pump body.

Putting a bar on pump body, also check that rotor and shoes assembly does not come in contact with it.

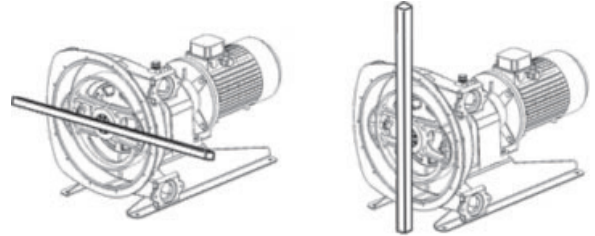

Put cover gasket 10 in pump body, starting at the top. Make sure that the two ends of gasket are firmly in contact.

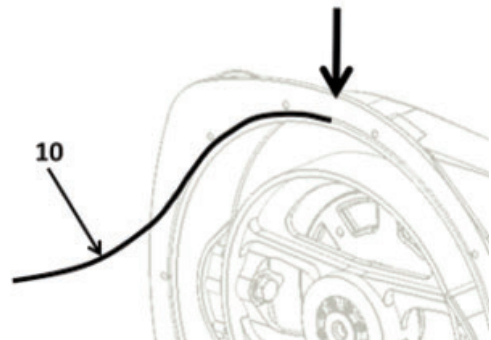



Incorrect mounting : risk of leak and body vacuuming impossible.



Correct mounting :



4. MAINTENANCE (continued)

 WARNING	BE CAREFUL WITH THE WEIGHT OF THE COVER WHEN ALL SCREWS ARE REMOVED.
	
<p>The weight of the parts can be dangerous and may provoke bodily injuries or material damages.</p>	

Place cover 2.

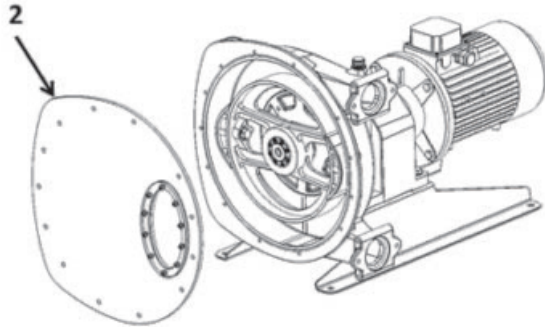

Screw and tighten screws 33 and their washers 34, starting by top ones to secure cover assembly.

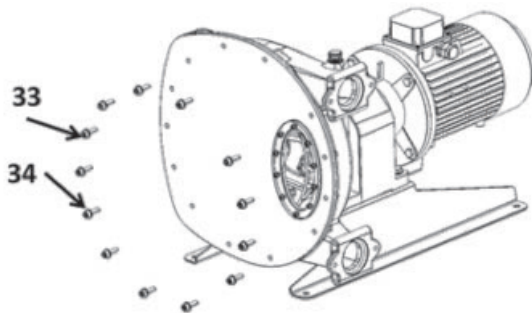

	HD25	HD32/40	HDX40
Tightening torque (Nm)	19	37	37



Fit hose in (see § HOSE REPLACEMENT) and fill the pump with lubricant (see § LUBRICANT REPLACEMENT).

4.4 Shaft seal replacement

Drain lubricant (see § LUBRICANT REPLACEMENT), remove hose (see § HOSE REPLACEMENT) and remove rotor (see § ROTOR ASSEMBLY REMOVAL).

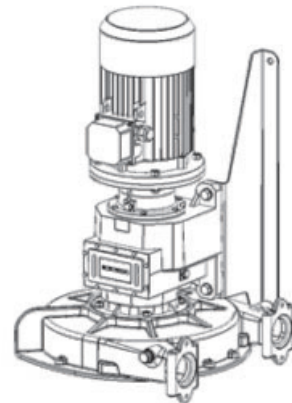

 WARNING	BE CAREFUL WITH THE WEIGHT OF THE PUMP.
	
<p>The weight of the parts can be dangerous and may provoke bodily injuries or material damages.</p>	

Using appropriate lifting device, put pump with reducer and motor in vertical, up position.

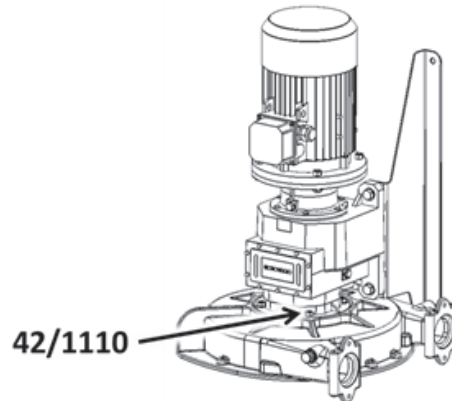

Loosen nuts 42 and their washers 1110.



 WARNING	BE CAREFUL WITH THE WEIGHT OF MOTOR AND REDUCER ASSEMBLY.
	
<p>The weight of the parts can be dangerous and may provoke bodily injuries or material damages.</p>	

4. MAINTENANCE (continued)

Using appropriate lifting device, lift motor and reducer assembly.

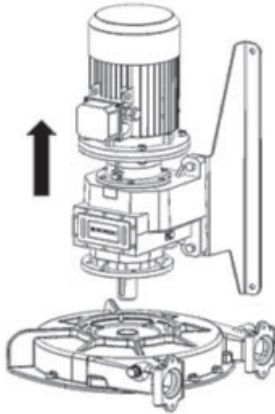

Remove shaft seal 26 from pump body. Put new shaft seal 26 in pump body.

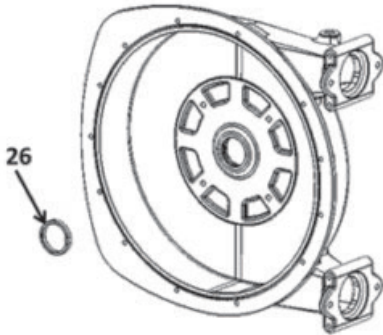

Make sure the shaft seal is in the right direction :

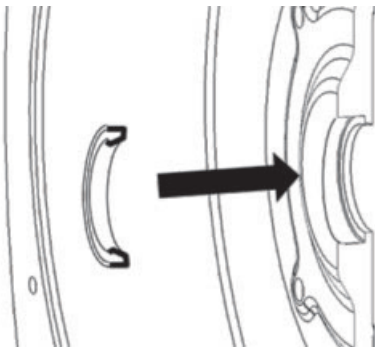

If necessary to replace friction ring 27, use a mallet and a chisel, to break and remove friction ring 27.

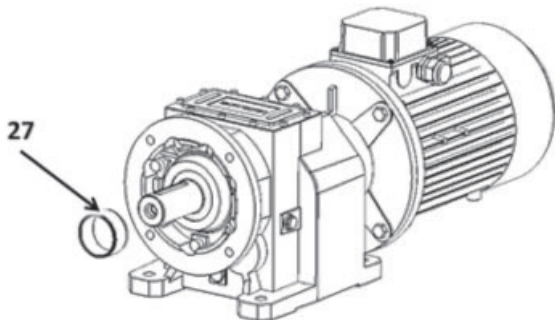

Heat new friction ring at $110 \pm 10^{\circ}\text{C}$ / $230 \pm 50^{\circ}\text{F}$.

	CAUTION	<p>BE CAREFUL WITH THE VERY HIGH TEMPERATURE OF FRICTION RING. USE APPROPRIATE HANDLING DEVICES.</p>
<p>Excessive temperature can cause injury or severe damage.</p>		

Put high temperature sealant Loctite* 648® or equivalent on reducer shaft from shaft shoulder and on a length corresponding to friction ring width.

Put new friction ring on shaft, pushing it against shaft shoulder.

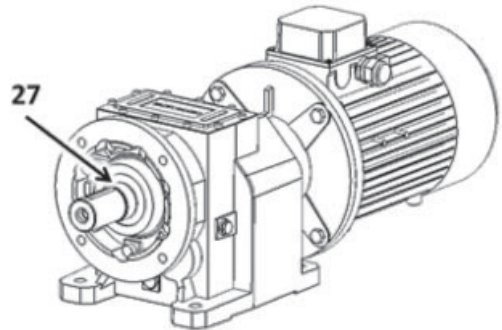

Let friction ring cool down before carrying on reassembly.

	WARNING	<p>BE CAREFUL WITH THE WEIGHT OF MOTOR AND REDUCER ASSEMBLY.</p>
<p>The weight of the parts can be dangerous and may provoke bodily injuries or material damages.</p>		

Using appropriate lifting device, put back motor + reducer assembly, checking correct motor connection box position.

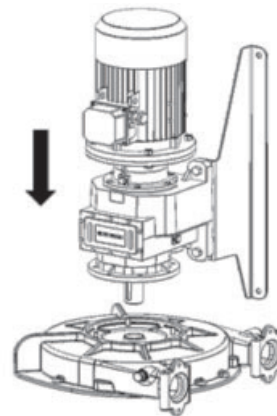

* Loctite® is a registered trademark.

4. MAINTENANCE (continued)

Put back nuts 42 and their washers 1110 and tighten them.

	HD25	HD32/40	HDX40
Tightening torque (Nm)	37	37	64

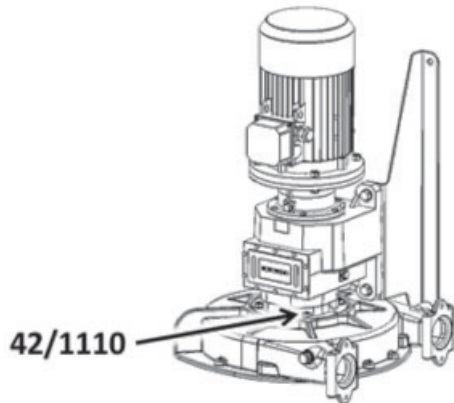

	WARNING
	BE CAREFUL WITH THE WEIGHT OF THE PUMP.
<p>The weight of the parts can be dangerous and may provoke bodily injuries or material damages.</p>	

Using appropriate lifting device, put back pump in normal position.

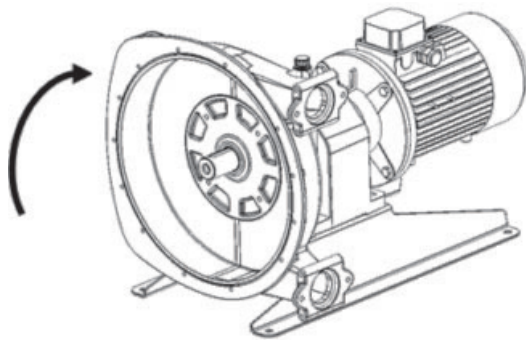

Refit rotor in the pump (see § ROTOR REMOVAL), refit hose (see § HOSE REPLACEMENT) and fill the pump with lubricant (see § LUBRICANT REPLACEMENT).

4.5 Shoes replacement

This operation can also be performed during rotor removal (see § ROTOR REMOVAL).

Removing shoes

Drain lubricant (see § LUBRICANT REPLACEMENT).

Rotate pump until a shoe is facing the windows.

Loosen and remove screws 37 and their washer 38.

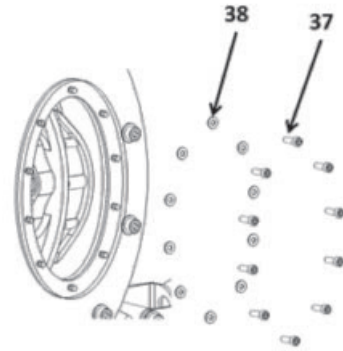

Remove window 15 and its seal 46.

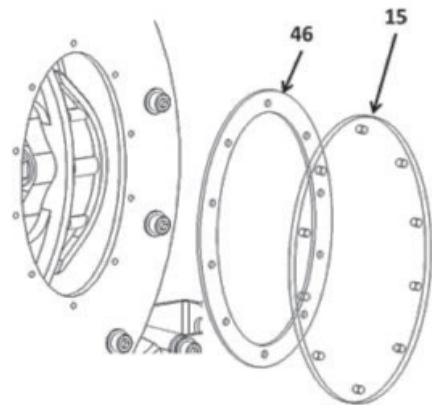

Holding the shoe 5 with a flat clip, loosen and remove screw 28 and its washer 29.

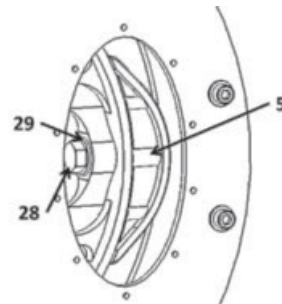

Pull the shoe 5 and its shim(s) 4, first in the radial direction to let pin come out of the rotor then out of the pump.

Note shims type and quantity to restore identical shimming when refitting the shoe.

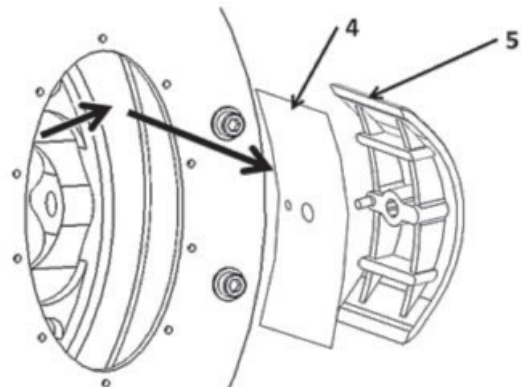

Repeat the same operations on the other shoe.

4. MAINTENANCE (continued)

Shoes refitting

Place shoes 5 and shims 4. Make sure shims type and quantity are identical to combination found when removing shoes. Screw and tighten screws 28 with their washers 29.

	HD25	HD32/40	HDX40
Tightening torque (Nm)	37	64	158

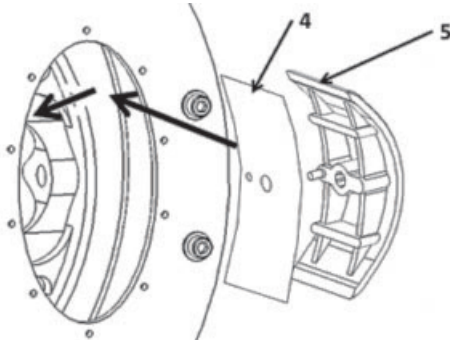

Check window seal 46 and replace it if necessary.

Place window 15 and its seal 46.

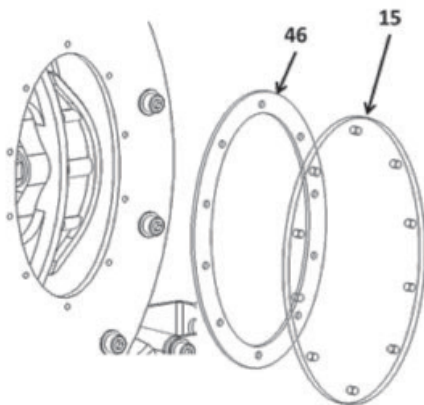

Screw and tighten screws 37 and their washers 38.

	HD25	HD32/40	HDX40
Tightening torque (Nm)	3	3	3

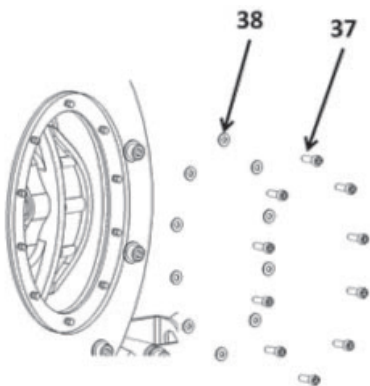

Repeat the same operations on the other shoe.

Fill the pump with lubricant (see § LUBRICANT REPLACEMENT).

4.6 Pump pressure setting

Suitable shimming of the shoes lengthens the service life of the hose.

SERVICE PRESSURE SPECIFIED AT ORDER

If the service pressure has been specified at order, the pump is shimmed in the factory to allow pump running at specified service pressure. No additional shimming is needed.

SERVICE PRESSURE NOT SPECIFIED AT ORDER OR MODIFICATION OF THE OPERATING PRESSURE OR THE TEMPERATURE OF THE PUMPED PRODUCT

If the service pressure has not been specified at order, the pump is pre-configured by the manufacturer for a service pressure up to 5 bar (72,5 psi).

For higher pressure value, one or more removable shims must be placed under the shoes. Similarly, for using the equipment at a lower service pressure, one or more removable shims should be removed from below the shoes.

REMINDER

Before modifying the shimming of the pump, check that the equipment (motor and pump) is compatible with the new operating conditions.

See NT 1101-Q00 SETTING HOSE COMPRESSION PUMPS HD.

5. TROUBLESHOOTING

PROBLEM	POSSIBLE CAUSE	SOLUTION
THE PUMP DOES NOT START	Electric power supply failure.	<p>Check the connections :</p> <ul style="list-style-type: none"> • There must be 3 phases. • The connections are suitable for the voltage (delta-star). • If possible, check the parameters for the different motor frequencies (starting torque, power input...).
	<p>When the pump has not been used for a long period of time, one shoe can have been kept outside the lubricant.</p> <p>As it has not been lubricated, it causes a lot of resistance on start up.</p>	<p>Operate the pump intermittently to try to free the rotor but do not be too insistent to prevent the reduction gear from being damaged.</p> <p>If the rotor remains stuck, contact your local dealer for instructions.</p>
	Sediments or other substances have built up inside the hose and are blocking the pump.	<p>Reverse the pump rotation direction or disassemble the hose.</p> <p>If the rotor remains stuck, contact your local dealer for instructions.</p>
ABNORMALLY LOW FLOW	The inlet or discharge valve is partially closed.	Open the inlet or discharge valve.
	Air is entering the inlet piping.	Check the inlet line.
	The pumped liquid is too viscous. Significant pressure drop at inlet.	Check the inlet line.
	The pump hose is damaged.	Replace the hose.
ABNORMALLY HIGH TEMPERATURE	The lubricant is not suitable.	Empty the pump body and replace the lubricant with one that is recommended by ABAQUE.
	The lubricant is dirty or too old.	Empty the pump body and replace the lubricant with a new ABAQUE lubricant.
	Temperature of the pumped fluid is too high.	Check the maximum fluid temperature allowed for the hose material.
	Pump speed too high.	Reduce speed.
ABNORMALLY SHORT HOSE LIFE SPAN	Lubricant is not suitable.	Empty the pump body and replace the lubricant with one that is recommended by ABAQUE.
	Chemical incompatibility between the hose and the pumped fluid.	Check the compatibility of the hose with the fluid and replace the hose with another one made of suitable material.
	Temperature of pumped fluid too high.	Check the maximum temperature permitted for the hose.
	The discharge pressure is too high.	Check the maximum pressure allowed for the pump. Reduce pressure drop at discharge.
	Pump speed is too high.	Reduce speed.
THE HOSE IS PULLED INTO THE PUMP BODY AT INLET	The pumped fluid contains impurities or sediments.	Reverse the pump rotation direction and use the upper port for inlet.
	Pressing gland is not sufficiently tightened.	Retighten the pressing gland.

6. TECHNICAL SPECIFICATIONS

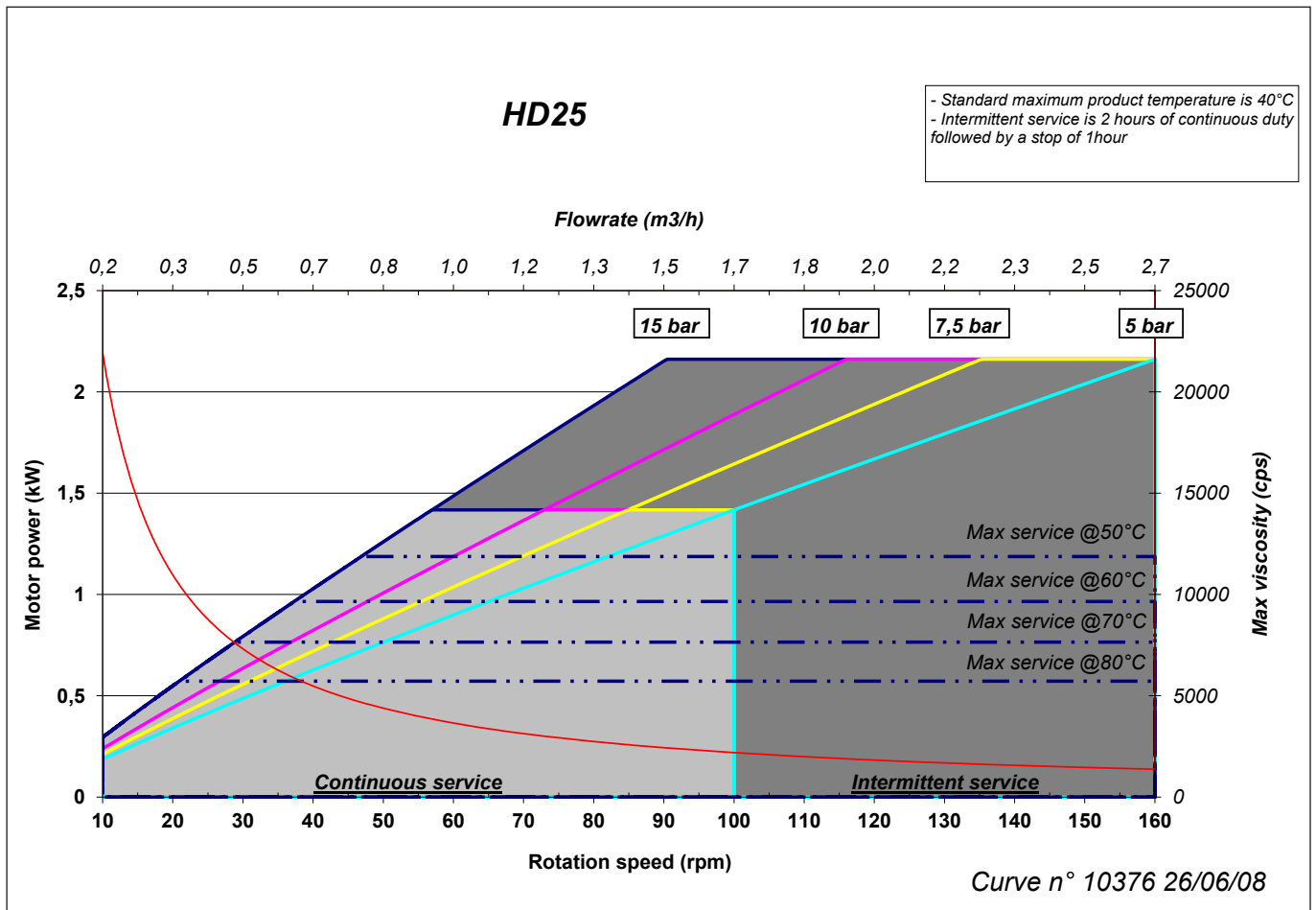

Light grey area : Continuous service (24h/24).

Dark grey area : Intermittent service (continually for 2 hours then stopped for 1 hour).

The flow rates shown have been obtained by pumping water at ambient temperature.

Above the limit of Max service at 50°C (122°F), the maximum temperature of liquid is 40°C (104°F).

ATEX pumps :

ATEX certified ABAQUE pumps have specific limits for use.
 Intermittent operation is forbidden.
 Refer to corresponding Instructions Manual for more informations.

6. TECHNICAL SPECIFICATIONS (continued)

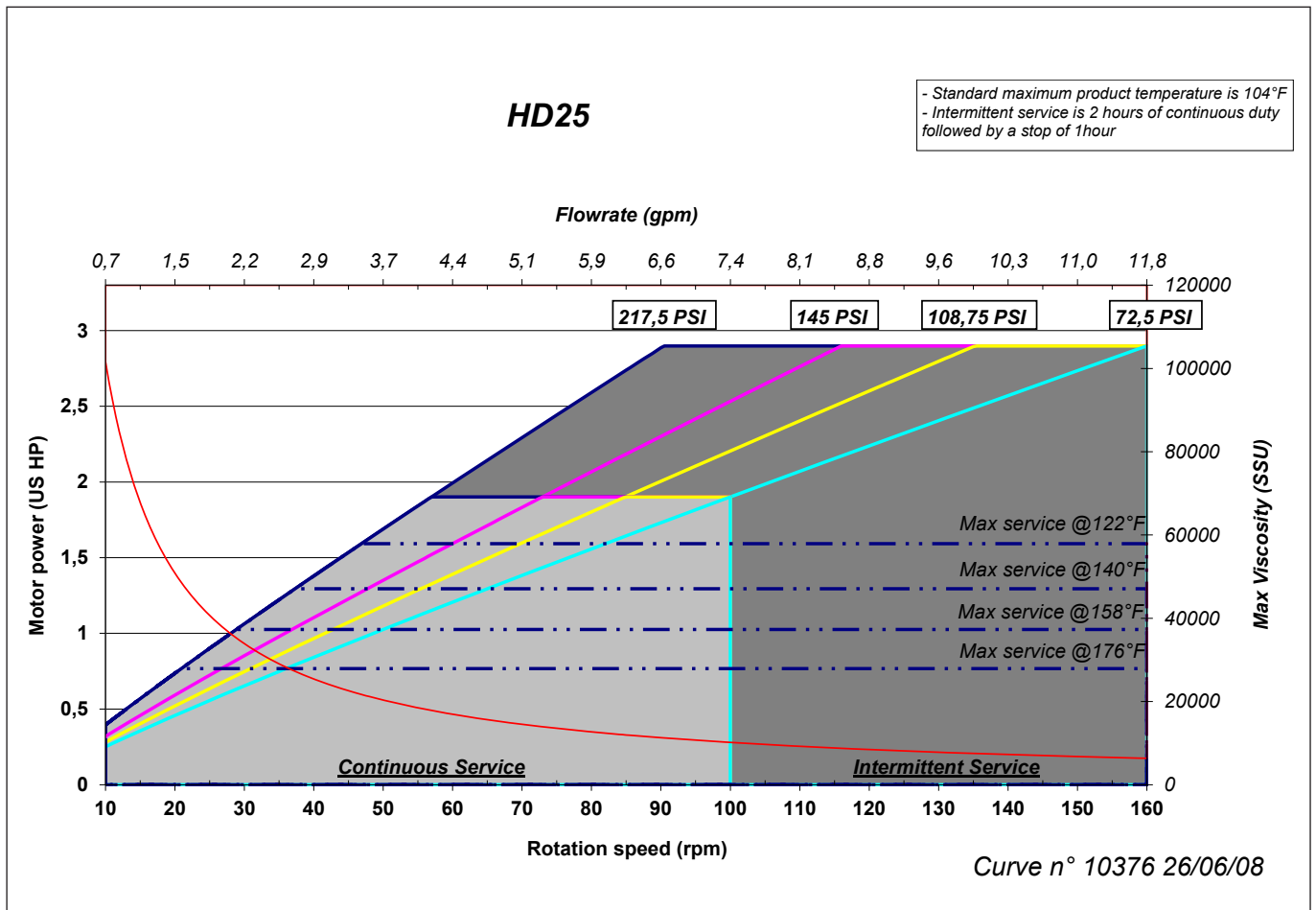

Light grey area : Continuous service (24h/24).

Dark grey area : Intermittent service (continually for 2 hours then stopped for 1 hour).

The flow rates shown have been obtained by pumping water at ambient temperature.

Above the limit of Max service at 50°C (122°F), the maximum temperature of liquid is 40°C (104°F).

ATEX pumps :

ATEX certified ABAQUE pumps have specific limits for use.
 Intermittent operation is forbidden.
 Refer to corresponding Instructions Manual for more informations.

6. TECHNICAL SPECIFICATIONS (continued)

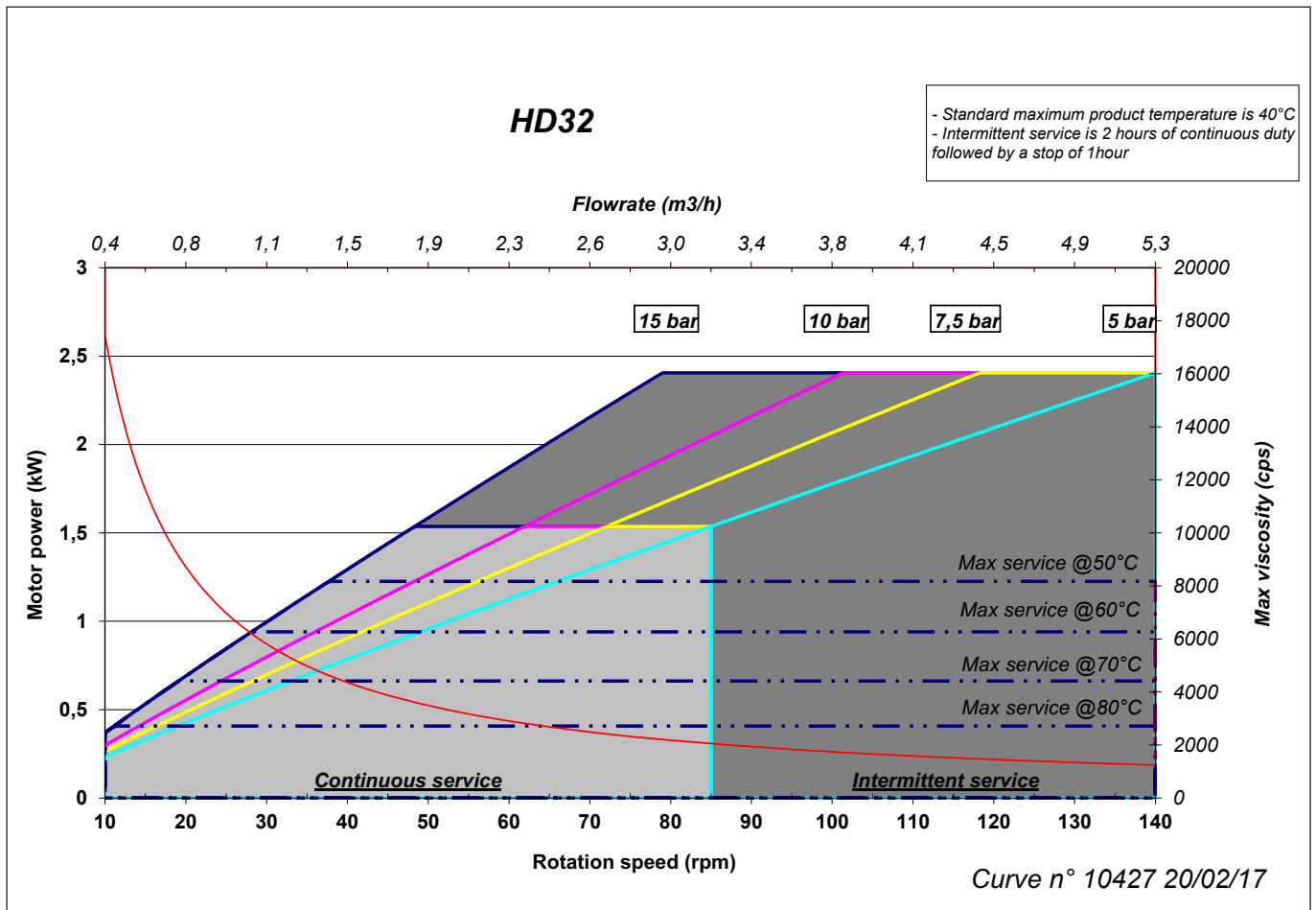

Light grey area : Continuous service (24h/24).

Dark grey area : Intermittent service (continually for 2 hours then stopped for 1 hour).

The flow rates shown have been obtained by pumping water at ambient temperature.

Above the limit of Max service at 50°C (122°F), the maximum temperature of liquid is 40°C (104°F).

ATEX pumps :

ATEX certified ABAQUE pumps have specific limits for use.
 Intermittent operation is forbidden.
 Refer to corresponding Instructions Manual for more informations.

6. TECHNICAL SPECIFICATIONS (continued)

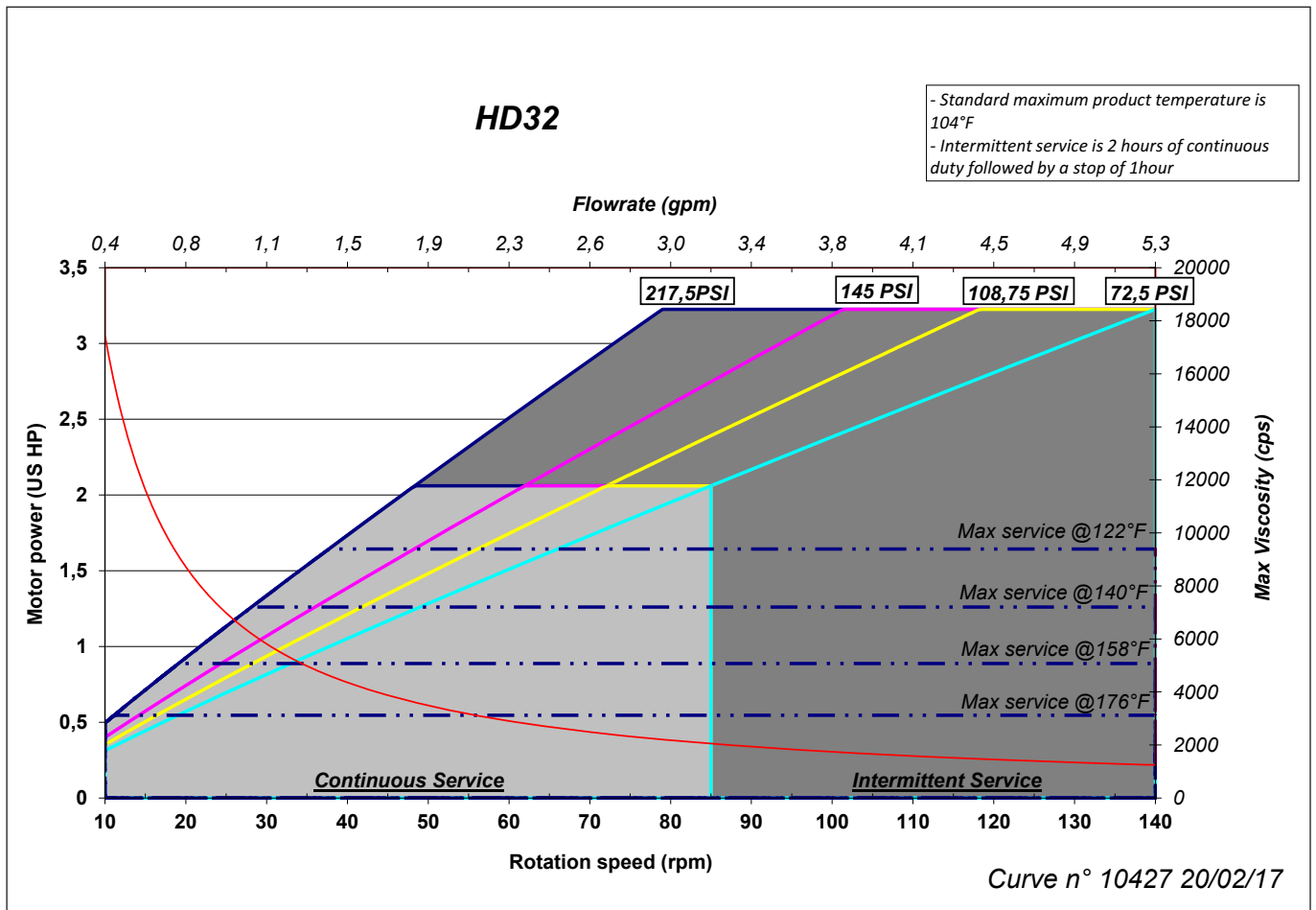

Light grey area : Continuous service (24h/24).

Dark grey area : Intermittent service (continually for 2 hours then stopped for 1 hour).

The flow rates shown have been obtained by pumping water at ambient temperature.

Above the limit of Max service at 50°C (122°F), the maximum temperature of liquid is 40°C (104°F).

ATEX pumps :

ATEX certified ABAQUE pumps have specific limits for use.
 Intermittent operation is forbidden.
 Refer to corresponding Instructions Manual for more informations.

6. TECHNICAL SPECIFICATIONS (continued)

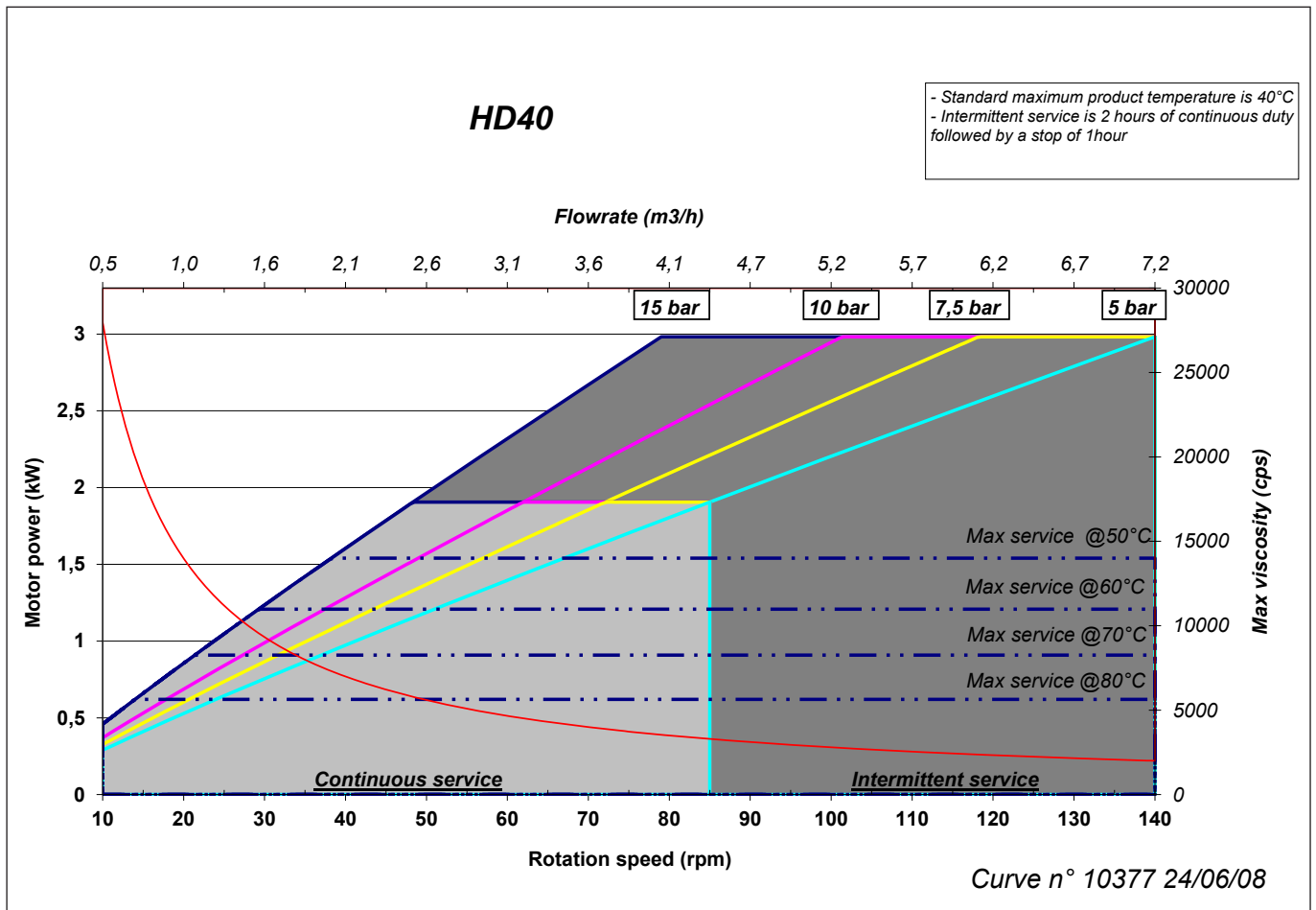

Light grey area : Continuous service (24h/24).

Dark grey area : Intermittent service (continually for 2 hours then stopped for 1 hour).

The flow rates shown have been obtained by pumping water at ambient temperature.

Above the limit of Max service at 50°C (122°F), the maximum temperature of liquid is 40°C (104°F).

ATEX pumps :

ATEX certified ABAQUE pumps have specific limits for use.
 Intermittent operation is forbidden.
 Refer to corresponding Instructions Manual for more informations.

6. TECHNICAL SPECIFICATIONS (continued)

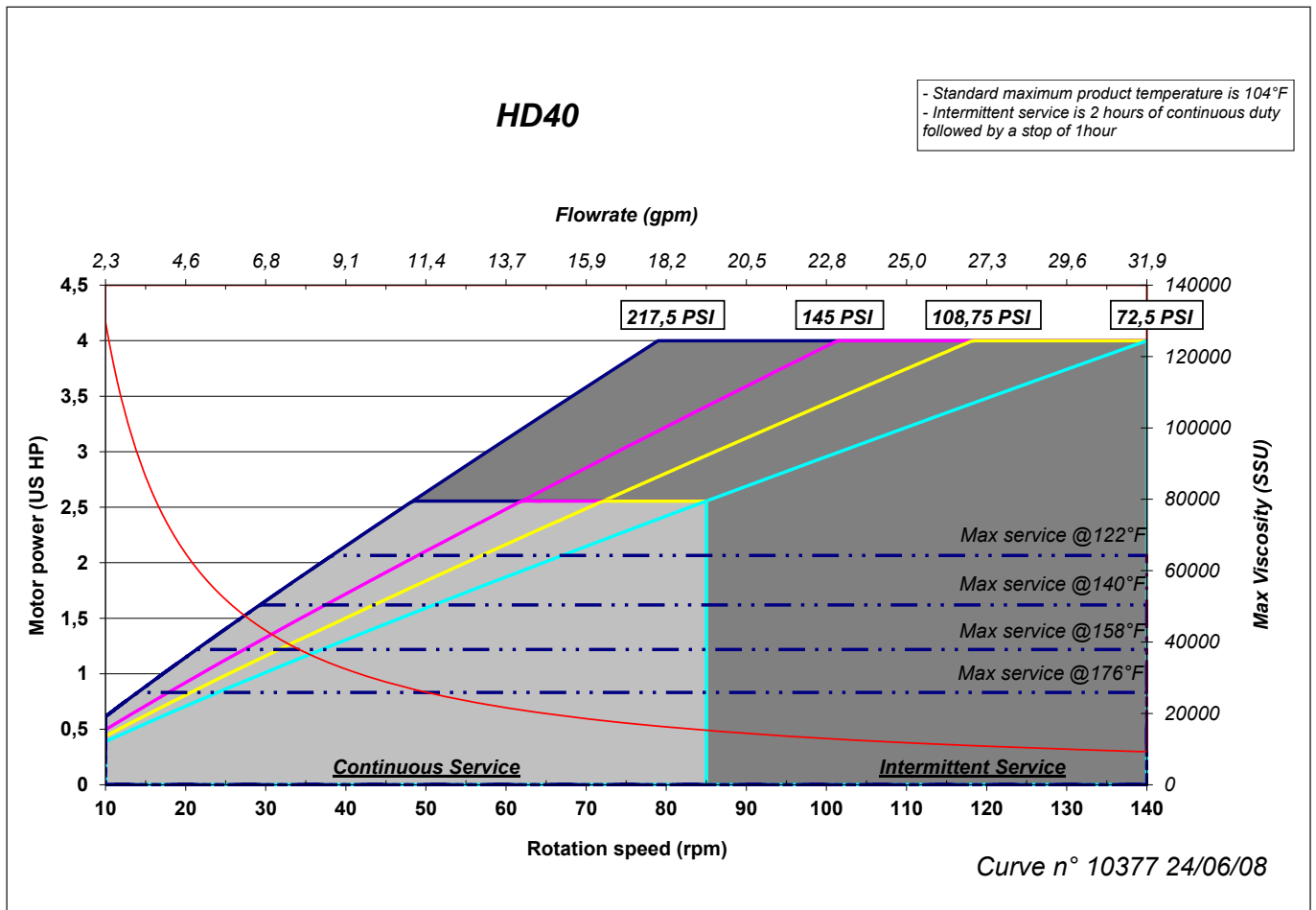

Light grey area : Continuous service (24h/24).

Dark grey area : Intermittent service (continually for 2 hours then stopped for 1 hour).

The flow rates shown have been obtained by pumping water at ambient temperature.

Above the limit of Max service at 50°C (122°F), the maximum temperature of liquid is 40°C (104°F).

ATEX pumps :

ATEX certified ABAQUE pumps have specific limits for use.
 Intermittent operation is forbidden.
 Refer to corresponding Instructions Manual for more informations.

6. TECHNICAL SPECIFICATIONS (continued)

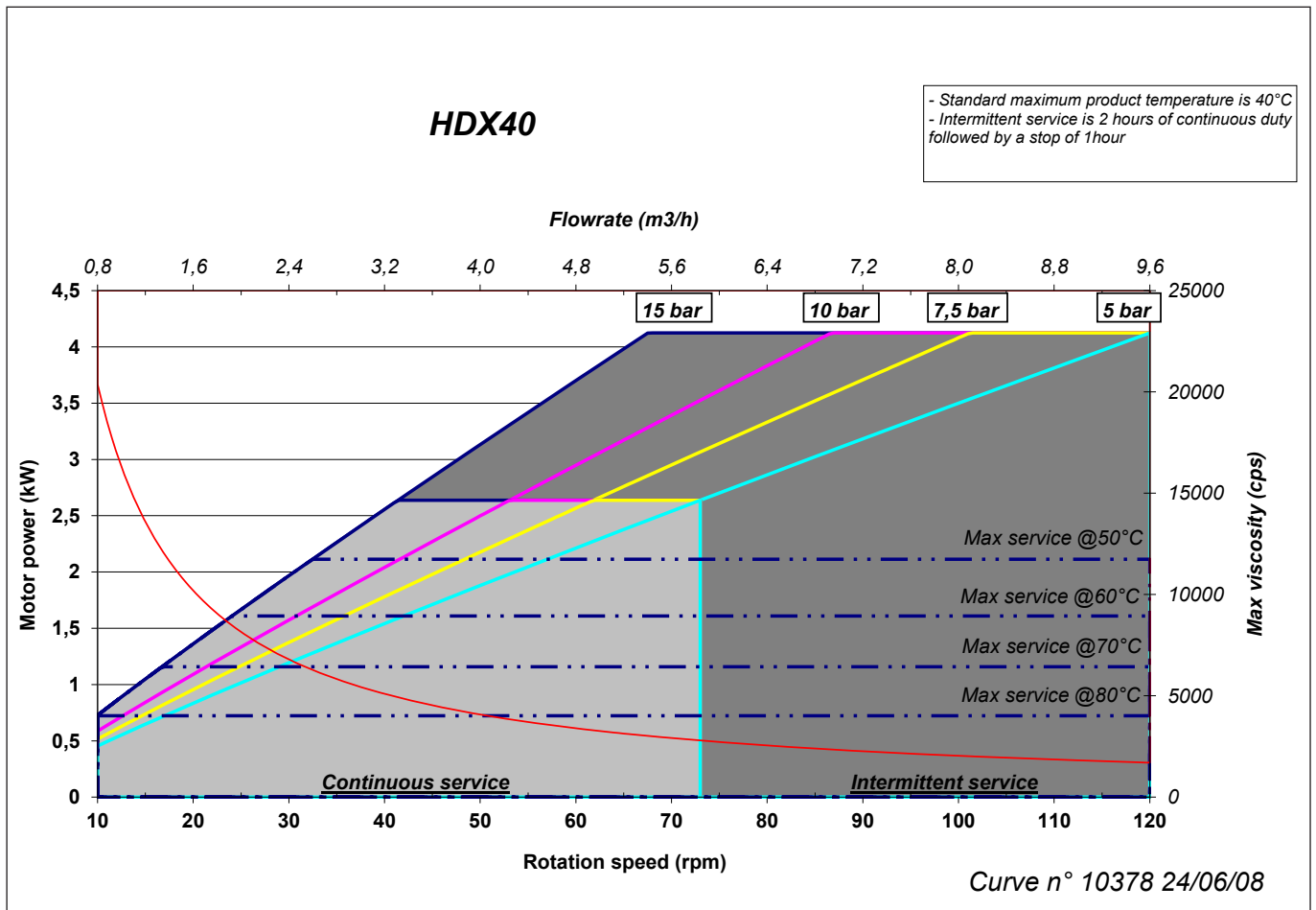

Light grey area : Continuous service (24h/24).

Dark grey area : Intermittent service (continually for 2 hours then stopped for 1 hour).

The flow rates shown have been obtained by pumping water at ambient temperature.

Above the limit of Max service at 50°C (122°F), the maximum temperature of liquid is 40°C (104°F).

ATEX pumps :

ATEX certified ABAQUE pumps have specific limits for use.
 Intermittent operation is forbidden.
 Refer to corresponding Instructions Manual for more informations.

6. TECHNICAL SPECIFICATIONS (continued)

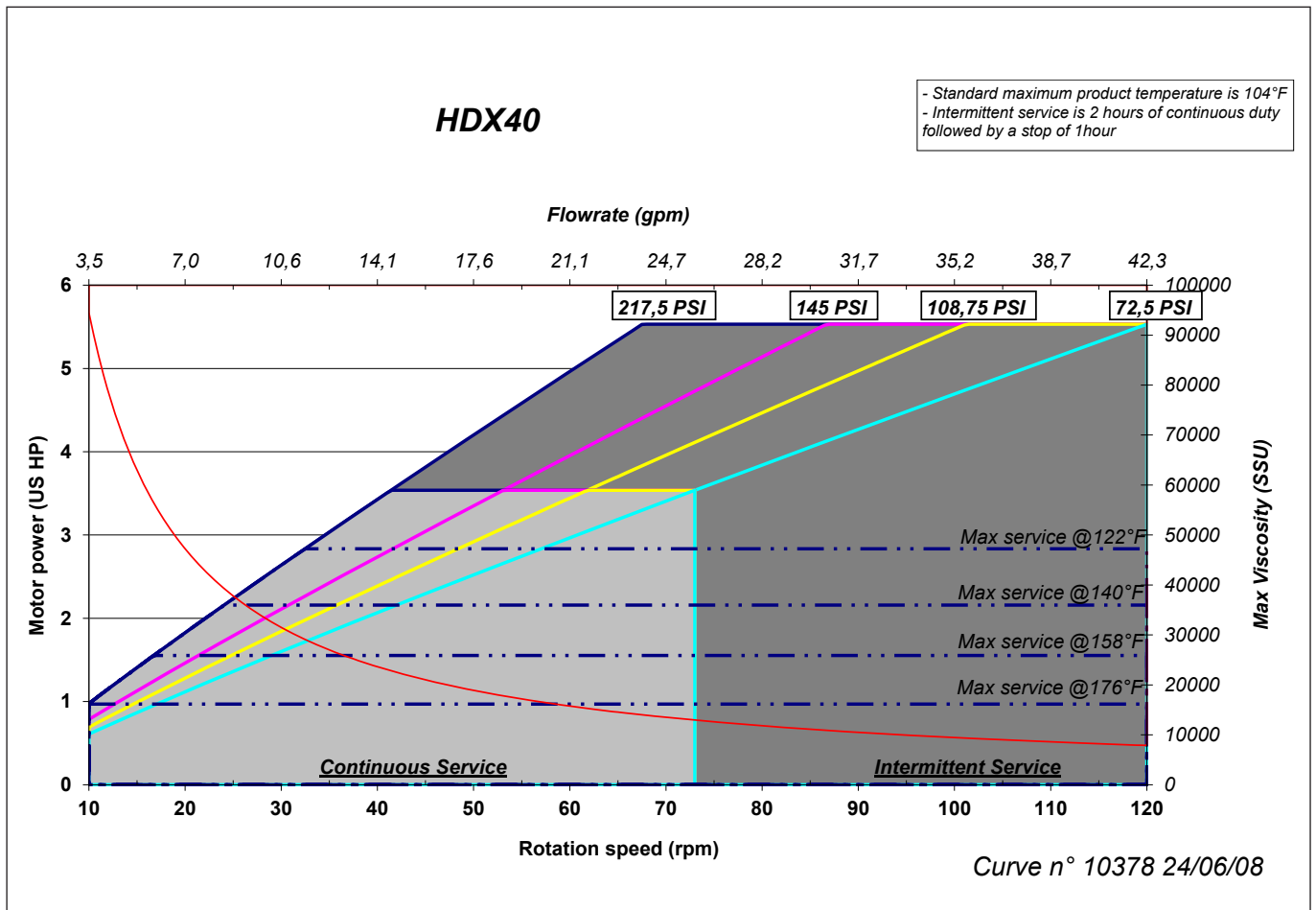

Light grey area : Continuous service (24h/24).

Dark grey area : Intermittent service (continually for 2 hours then stopped for 1 hour).

The flow rates shown have been obtained by pumping water at ambient temperature.

Above the limit of Max service at 50°C (122°F), the maximum temperature of liquid is 40°C (104°F).

ATEX pumps :

ATEX certified ABAQUE pumps have specific limits for use.
 Intermittent operation is forbidden.
 Refer to corresponding Instructions Manual for more informations.

7. OVERALL DIMENSIONS

CAD generated and maintained drawing. All printed and electronic copies outside of PSG AUXERRE database are "Uncontrolled" and shall be used for reference only.

Enc HD25

Vitesse (Speed)	B	C	Poids (Weight)
34 tr/min (RPM)	[24,449] 621.2	[27,087] 688.7	72
49 tr/min (RPM)	[24,449] 621.2	[27,087] 688.7	74
59 tr/min (RPM)	[26,654] 677.8	[29,331] 745.3	82

S	Emplacement sonde de température suivant sens de rotation (voir notice ATEX) trou M6
S	Thermal sensor location according rotation direction (refer to ATEX instruction notes) M6 hole

P	Plaque de pompe
P	Pump plate

Prise de terre Ø9 [0,354]
(Safety ground)

HD25 Orifices a droite (Ports to the right)

COMMENTS OR DIMENSIONS IN BRACKETS ARE INDICATIVE
UNLESS OTHERWISE SPECIFIED, ALL DIMENSIONS ARE IN MM

NAME	DATE	PROJECTION
DRAWN MDD	2025-04-29	FIRST ANGLE
APPV D	2025-06-13	

THIS DOCUMENT CONTAINS PROPRIETARY INFORMATION OF PSG. A DOCUMENT RECEIVED AND POSSIBLE TO REPRODUCE OR DISCLOSE IS CONTROVERSIAL TO PSG. A DOCUMENT RECEIVED AND POSSIBLE TO REPRODUCE OR DISCLOSE IS CONTROVERSIAL TO PSG. A DOCUMENT RECEIVED AND POSSIBLE TO REPRODUCE OR DISCLOSE IS CONTROVERSIAL TO PSG. A DOCUMENT RECEIVED AND POSSIBLE TO REPRODUCE OR DISCLOSE IS CONTROVERSIAL TO PSG.

WEIGHT: See table
SCALE: 1:5 DO NOT SCALE DRAWING SIZE: A3 SHEET 1 OF 2

7. OVERALL DIMENSIONS (continued)

CAD generated and maintained drawing. All printed and electronic copies outside of PSG AUXERRE database are "Uncontrolled" and shall be used for reference only.

ENC HD32-HD40

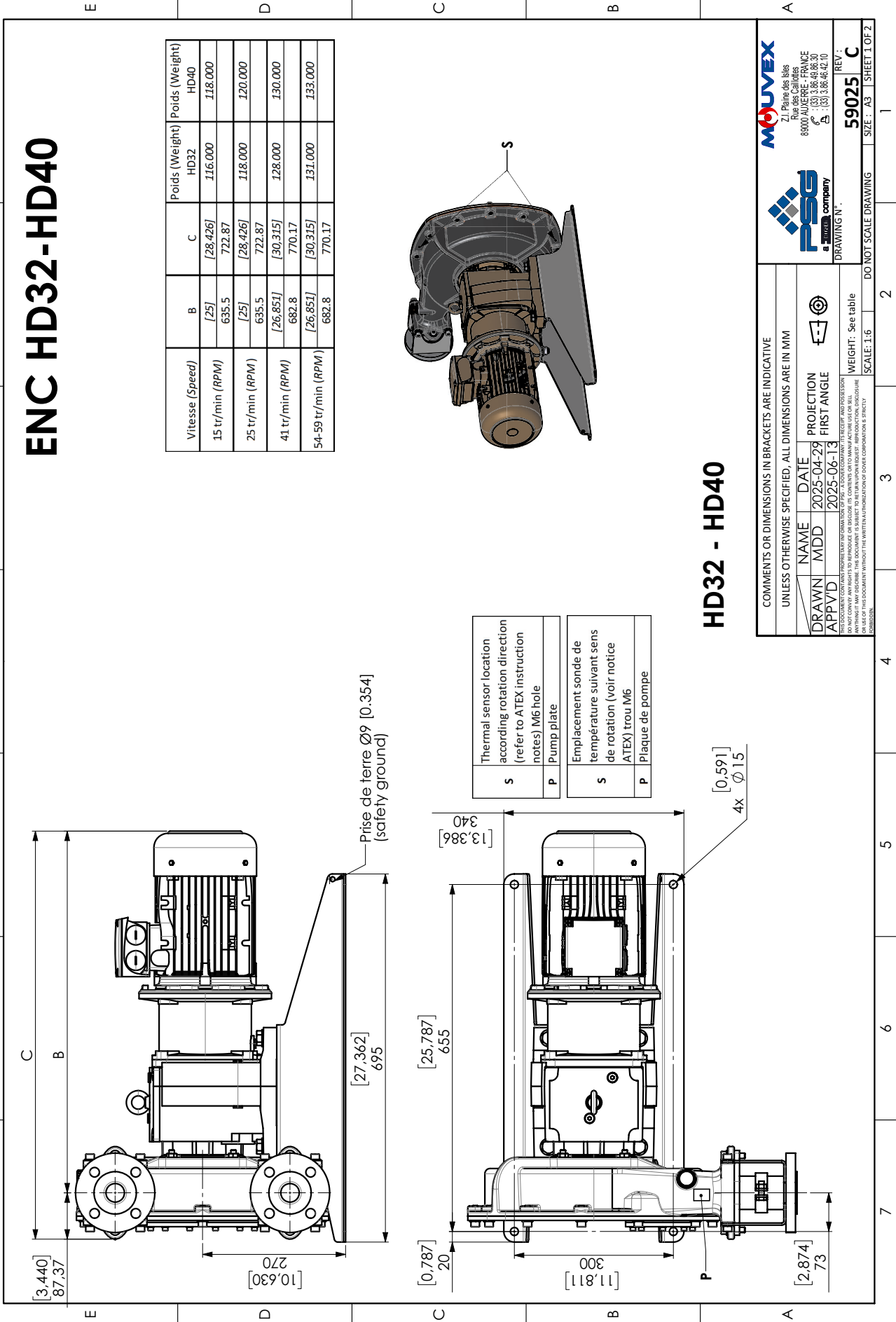

HD32 - HD40

COMMENTS OR DIMENSIONS IN BRACKETS ARE INDICATIVE
UNLESS OTHERWISE SPECIFIED, ALL DIMENSIONS ARE IN MM

NAME	DATE	PROJECTION
MDD	2025-04-29	FIRST ANGLE
APPVJ	2025-06-13	

DO NOT COPY ANY PARTS TO REPRODUCE OR DISCLOSE IN ANY MANNER WITHOUT THE WRITTEN AUTHORIZATION OF PSG. A DOCUMENT RECEIVED BY THE CUSTOMER IS THE PROPERTY OF PSG. IT IS TO BE DESTROYED UPON THE RECEIPT AND RETURN TO PSG. ANY REPRODUCTION OR DISSEMINATION OF THIS DOCUMENT WITHOUT THE WRITTEN AUTHORIZATION OF PSG CORPORATION IS STRICTLY FORBIDDEN.

WEIGHT: See table
SCALE: 1:6
DO NOT SCALE DRAWING

PSG a **MOVEX** company
Z.I. Paine des Isles
Rue des Calottes
89000 AUXERRE - FRANCE
☎ : (+33) 3.86.49.95.30
✉ : (+33) 3.86.46.46.10

DRAWING N°: 59025
REV: C
SIZE: A3 | SHEET 1 OF 2

7. OVERALL DIMENSIONS (continued)

CAD generated and maintained drawing. All printed and electronic copies outside of PSG AUXERRE database are "Uncontrolled" and shall be used for reference only.

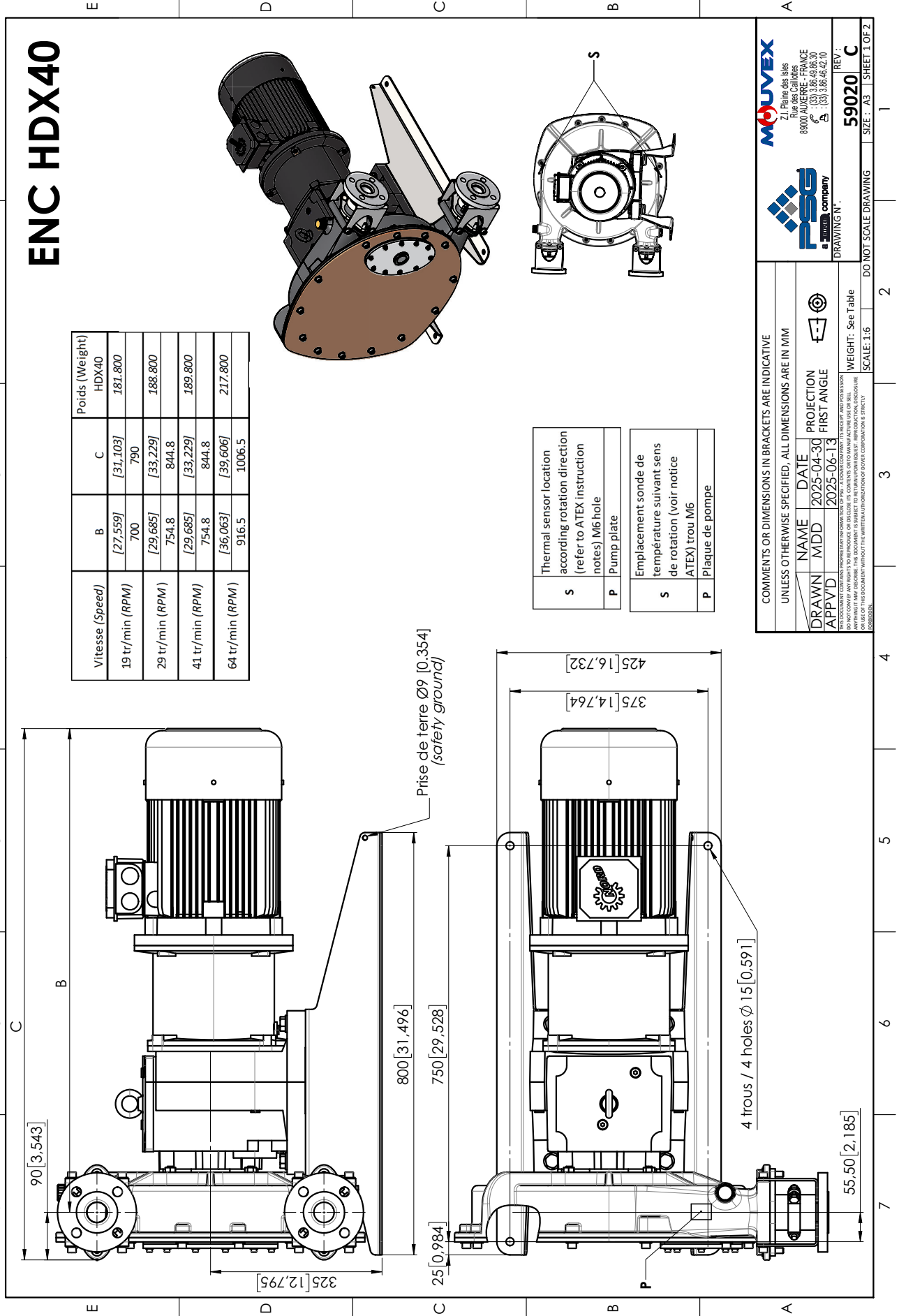

MOVEX
Z.I. Paine des Isles
Rue des Calottes
89000 AUXERRE - FRANCE
☎ (+33) 3.86.49.95.30
✉ (+33) 3.86.46.42.10

PSG
a **STANDA** company

DRAWING N°: **59020 C** REV: **C**

COMMENTS OR DIMENSIONS IN BRACKETS ARE INDICATIVE
UNLESS OTHERWISE SPECIFIED, ALL DIMENSIONS ARE IN MM

NAME	DATE	PROJECTION
MDD	2025-04-30	FIRST ANGLE
APPV	2025-06-13	

WEIGHT: See Table
SCALE: 1:6
DO NOT SCALE DRAWING

SIZE: A3 | SHEET 1 OF 2