

Puncture detector for ABAQUE HD squeezed tube pumps

INSTALLATION

OPERATION

WARRANTY :

Puncture detectors for ABAQUE pumps are covered 24 months by warranty within the limits mentioned in our General Sales Conditions. In case of a use other than that mentioned in the Instructions manual, and without preliminary agreement of ABAQUE, warranty will be canceled.



Z.I. La Plaine des Isles - F 89000 AUXERRE - FRANCE
Tél. : +33 (0)3.86.49.86.30 - Fax : +33 (0)3.86.49.87.17
contact.abaque@psgdover.com • www.psgdover.com/abaque

Your distributor :

PUNCTURE DETECTOR

FOR ABAQUE HD SQUEEZED TUBE PUMPS

SAFETY, INSTALLATION AND OPERATION INSTRUCTIONS

SUMMARY	Page
1. WORKING PRINCIPLE	3
2. TECHNICAL CHARACTERISTICS	3
3. CONNECTION DIAGRAM	3
4. DETECTOR MOUNTING	4

REMARKS :

The puncture detection kit for ABAQUE squeezed tube pumps **MUST** be installed in equipment installation layouts designed by qualified personnel. The installation **MUST** be in conformity with local standards, national regulations and safety rules.

This manual is intended for the installation and start up of puncture detection kits for squeezed tube pumps and **MUST** accompany the kit.

The squeezed tube pump servicing shall have to be carried out **ONLY** by qualified technicians. This maintenance shall have to respect local standards, national regulations and safety rules.

This manual, with all instructions and precautions, is to be read in its integrality **BEFORE** any use of the ABAQUE pumps.

All warning and utilisation labels and stickers are to be left in place.

Definition of safety symbols



This is a **SAFETY ALERT SYMBOL**.

When you see this symbol on the product, or in the manual, look for one of the following signal words and be alert to the potential for personal injury, death or major property damage.

DANGER

Warns of hazards that **WILL** cause serious personal injury, death or major property damage.

WARNING



Warns of hazards that **CAN** cause serious personal injury, death or major property damage.



CAUTION

Warns of hazards that **CAN** cause personal injury or property damage.

NOTICE

Indicates special instructions which are very important and must be followed.

 CAUTION	<p style="text-align: center; margin: 0;">THE PUMP LUBRICANT IS VERY SLIPPERY AND MAY CAUSE SERIOUS INJURY. ANY SPILLS MUST BE CLEANED UP.</p>
	
<p style="text-align: center;">Slippery lubricant. Spills should be cleaned up.</p>	

 WARNING	<p style="text-align: center; margin: 0;">DISCONNECT THE ELECTRICITY SUPPLY BEFORE ANY MAINTENANCE OPERATION.</p>
	
<p style="text-align: center;">Dangerous voltage. Can cause injury and death.</p>	

1. WORKING PRINCIPLE

The pipe puncture detection of the squeezed tube pump is ensured by a capacitive proximity detector mounted on the level pipe of the pump.

The capacitive proximity detector detects metallic and non metallic materials.

2. TECHNICAL CHARACTERISTICS

Capacitive detectorKI0024
Supply voltage20 to 250 V AC/DC
Hold output current250 mA (50°C)
.....200 mA (70°C)
Call output current1,5 A (20 ms / 0,5 Hz)

Consumption at 24 V<10mA
Switching frequency25 Hz AC / 40 Hz DC
Ambient utilisation temperature ...-25°C to +70°C
.....(-13°F to +158°F)
ProtectionIP 65

3. CONNECTION DIAGRAM

The connection is made by terminal up to 2,5 mm²

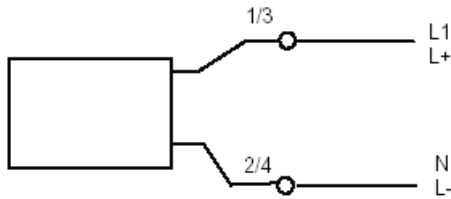

Two different functioning modes are possible :

- Normally open contact :
- Normally closed contact :

The normally closed contact is obtained by cutting the detector strap :

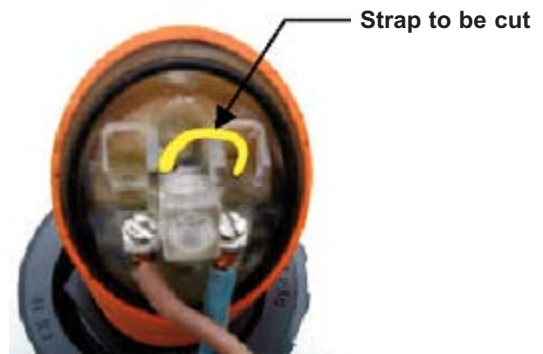

4. DETECTOR MOUNTING

HD : 10 - 15 - 20 - 25 - 32 - 40 - X40

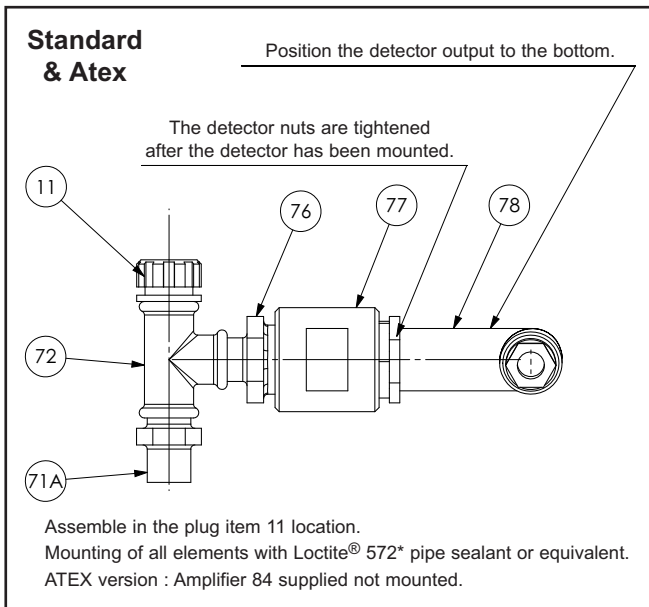

- Remove the plug 11.
- Screw the fitting 71A in place of plug 11.
- Mount the tee 72 and then the plug 11.
- Screw the fitting 76 on the tee 72.
- Mount the detector 78 in the connector 77.
- As far as possible, position the detector output to the bottom.
- Screw the nuts in the detector.
- Perform wiring operations as per § CONNECTION DIAGRAM.

HD : 50 - 65 - X65 - 80 - X80 - 100

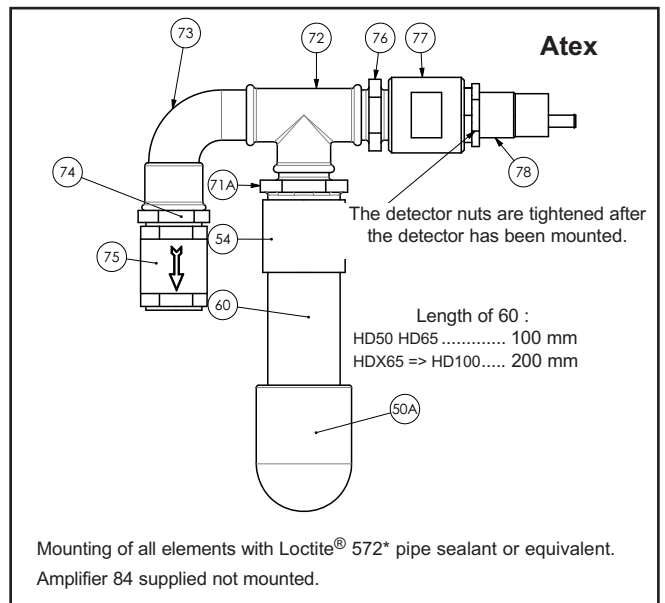
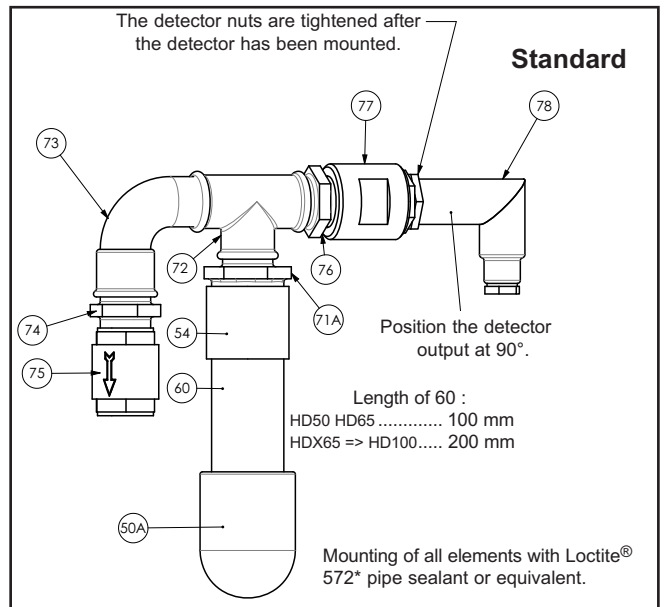

- Remove the plug 23A.
- Mount the elbow 50A, the cylindrical fitting 60 and the female fitting 54 in order.
- Screw the fitting 71A on the female fitting 54.
- Mount the tee 72 and then the elbow 73.
- Screw the fitting 74 on the elbow 73.
- Screw the valve 75 on the fitting 74.
- Screw the fitting 76 on the tee 72.
- Mount the detector 78 in the connector 77.
- Standard version : Position the output of the detector 78 at 90° in a downward direction.
- Screw the nuts in the detector.
- Perform wiring operations as per § CONNECTION DIAGRAM.

* Loctite® is a registered trademark.